



PowerVent with Honeywell Electronic Control
(PowerVent ESII and PowerVent ESII with Electronic Control)

Service Mode (electronic Control Only)

Service Mode is entered by pressing down and holding all keys for 5 seconds. Alarm history of the connected appliance is displayed, alarms are indexed by “E1” for most recent alarm, “E2” for second alarm to “E9” for ninth alarm (alarm history can be scrolled by pressing “Up” and “Down” keys). Displayed alarm history can be cleared by pressing “Clear” key. If the alarm history is empty dashes “--” are displayed instead of “E1”, E2” to “E9” and particular error numbers. Setup Mode is closed and enters User Mode after 5 minutes of user inactivity or when “Done” key is pressed.

Control Settings

SETTING	VALUE	SETTING	VALUE
Set point Range	90°F (32°C) to 160°F (71°C)	Flame Prove Igniter Off	0.5 µA
“HOT” Set point	120°F (49°C)	Flame Prove RUN	0.7 µA
Differential	15°F (9°C)	Flame Lost	< 0.5 µA
ECO Limit	199°F (93°C)	Strong Flame	≥ 1.5 µA

Timings

IGNITION STATE	TIMING
Soft Lockout	5 minutes; then retries for main burner
ECO Limit Lockout	Indefinite
Flammable Vapor Sensor Lockout	Indefinite
Hardware Error Lockout / Hard lockout	Indefinite
Pre-purge	2 seconds
Trial For Ignition	90 seconds
Flame Stabilization Period	3 seconds
Inter-purge	90 seconds
Flame Failure Response Time	1.5 seconds
Post-purge	30 seconds
Pressure Switch Fault Delay (failed open/closed)	2 minutes



Error Code Flash Display

Display Code	Gas Valve “Status” Flash Code	Control Status
None	Short flash once every four seconds	IDLE (no call for heat, no fault conditions)
None	“Heartbeat”, alternates bright/dim	Call For Heat (no fault conditions)
12	One Flash, three second pause	Low flame signal (control continues to operate)
44	Two Flash, three second pause	Pressure switch failed closed
46	Three Flash, three second pause	Pressure switch failed open
31	Four Flash, three second pause	Thermal Cut Off limit lockout
14	Five Flash, three second pause	Flame out of sequence
11	Six-One Flash, three second pause	Failed trial for ignition
45	Six-Two Flash, three second pause	Recycle limit - PS/limit opened
13	Six-Three Flash, three second pause	Recycle limit - flame lost
10	Six-Five Flash, three second pause	Hard Lockout; manual reset required
47	Seven Flash, three second pause	Flammable vapor sensor lockout
49	Eight-One Flash, three second pause	FVS fault detected
89	Eight-Two Flash, three second pause	Temperature sensor fault detected
15	Eight-Three Flash, three second pause	Electronics fault detected
93	Eight-Four Flash, three second pause	Valve fault detected



PowerVent with Honeywell Electronic Control
(PowerVent ESII and PowerVent ESII with Electronic Control)

No Power or No Blower Motor

Indications	Display
Nothing happens at all. No blower motor; no sounds.	There is not a display code for this problem.
Troubleshooting	
<ol style="list-style-type: none"> 1. Check wall plug power with a table lamp. 2. Check that the unit is plugged in. 3. Verify gas control switch is ON. 4. Verify power to the gas control thru the black wire (pin #1) on the gas valve Molex. Turn up thermostat on gas valve; observe blinking blue light; otherwise replace control. 5. Turn thermostat all the way up. Verify power to the blower at the yellow wire (pin #3) on the gas valve Molex. Replace blower if there is power on the yellow wire, but no blower motor. Replace control if you have power on the black wire and not on the yellow wire. 	

Error 10

Indications	Display
The control is in hard lockout.	Six-Five Flash, three second pause
Troubleshooting	Solution
<ol style="list-style-type: none"> 1. Low gas supply pressure 2. Carbon buildup on electrode 3. Igniter Wire damage 4. Pilot tube restriction 5. Main burner supply tube restriction 	<ol style="list-style-type: none"> 1. See Error Code history for most recent fault code. (on DISPLAY models only) 2. This lockout can only be cleared by manually cycling the control power.

Error 11

Indications	Display
Failed trial for ignition; Maximum ignition attempts. If flame is not sensed during the Trial period, the igniter turns off, the pilot valve closes, the control runs the inducer through Post-purge then turns off the inducer and enters Soft Lockout and flashes the Soft Lockout error code. The control remains in Soft Lockout for 5 minutes before responding to the demand for heat. If the control has entered Soft Lockout three times, the control will enter hard lockout.	Six-One Flash, three second pause
Troubleshooting	Solution
<ol style="list-style-type: none"> 1. Low gas supply pressure 2. Carbon buildup on electrode 3. Igniter Wire damage 4. Combustion air blockage 5. Pilot tube restriction 	<ol style="list-style-type: none"> 1. Verify gas pressure with rating plate on water heater. 2. Clean spark electrode and pilot hood with steel wool. 3. Verify igniter spark at electrode 4. Verify air inlet holes on side of water heater are clean and clear 5. Inspect pilot tube for obstructions 6. This lockout can only be cleared by manually cycling the control power.



**PowerVent with Honeywell Electronic Control
 (PowerVent ESII and PowerVent ESII with Electronic Control)**

Error 12

Indications	Display
Low flame signal (control continues to operate)	One Flash, three second pause
Troubleshooting	Solution
<ol style="list-style-type: none"> 1. Low gas supply pressure 2. Carbon buildup on electrode 3. Pilot tube restriction 	<ol style="list-style-type: none"> 1. Verify gas pressure with rating plate on water heater. 2. Clean spark electrode and pilot hood with steel wool. 3. Inspect pilot tube for obstructions

Error 13

Indications	Display
<p>Flame lost during RUN: During the heating cycle, the <i>pilot flame</i> is lost. The control turns off the pilot and main valves, runs Inter-purge, increments the Recycle Count and, if the Recycle count limit has not been reached, begins another Trial for Ignition. If the Recycle Count Limit has been reached, the control enters soft lockout. The control remains in soft lockout for 15 minutes before responding to the Demand for Heat. This clears the Recycle Count to allow for another set of "Recycle Count Limit" recycles. A total of three such sets of ignition trials including the first ignition trial set to be attempted. If the control has entered soft lockout for the total number of ignition trials as specified above the control will enter hard lockout. This lockout can be cleared by manually cycling the control power.</p>	Six-Three Flash, three second pause
Troubleshooting	Solution
<ol style="list-style-type: none"> 1. Check pilot flame to insure flame is not lifting away from flame sense hood – when main burner ignites. 2. Check static and dynamic gas supply to insure pressure is maintained when main burner lights. 3. Check for leaking pilot supply tube. 4. Check for carbon/soot buildup on pilot grounding strap. 5. Baffle or Baffle collar is not in correct position. 	<ol style="list-style-type: none"> 1. Verify gas pressure with rating plate. 2. Clean pilot supply hood to enhance flame rectification readings. 3. Reposition pilot igniter into proper position. 4. Replace pilot igniter. 5. If blower motor is hot to the touch, the inspect baffling and baffle collar. 6. Inspect baffle and baffle collar for proper positioning.

Error 14

Indications	Display
Flame Sensed Out Of Sequence - the control only looks for pilot flame when the inducer is running. If flame is present when the pilot valve is not open, the control proceeds to Wait Flame Lost and flashes the Flame out Of Sequence error code. Blower remains on.	Five Flash, three second pause
Troubleshooting	Solution
<ol style="list-style-type: none"> 1. Pilot or main burner valve has failed open 	<ol style="list-style-type: none"> 1. Recycle heater to verify error code 2. Replace gas control valve



PowerVent with Honeywell Electronic Control
(PowerVent ESII and PowerVent ESII with Electronic Control)

Error 15

Indications	Display
Electronics fault detected - The electronic control module contains a relay for communicating with the display.	Eight-Three Flash, three second pause
Troubleshooting	Solution
<ol style="list-style-type: none"> Panel fault Gas control fault 	<ol style="list-style-type: none"> Recycle heater to verify error code Replace display panel Replace gas control valve

Error 31

Indications	Display
ECO limit lockout - Water temperature sensed in excess of ECO limit (199°) - the control immediately turns off pilot and main valves and enters ECO Limit Lockout. During ECO Limit Lockout, the inducer motor runs continuously.	Four Flash, three second pause
Troubleshooting	Solution
<ol style="list-style-type: none"> Thermal well fault (see below) Gas control fault 	<ol style="list-style-type: none"> The sensed water temperature must be below 120F° Power must be cycled to remove the control from ECO limit hard lockout.

<ol style="list-style-type: none"> Water temperature sensor fault. Measure the OHMS resistance between pins 1 and 2; then measure the resistance between pins 3 and 2. The two number should be the same. <p>See chart on last page to convert OHMS to temperature.</p>	<ol style="list-style-type: none"> Recycle power to verify error Replace thermal well
----------------------------------------------------------------------------------------------------------------------------------------------------------------------------------------------------------------------------------------------------------------------------------------	---------------------------------------------------------------------------------------------------------------

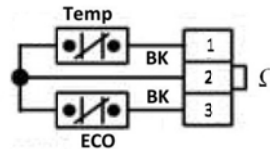

Error 44

Indications	Display
PS Failed Closed at start of Call for Heat - the control waits four seconds then begins to flash error code (44). The control waits 2 minutes, and then turns on the inducer for 30 seconds. The inducer shuts off after 30 seconds and the control returns to waiting for the pressure switch to open. The control will attempt this sequence 5 times before entering into a hard lockout.	Two Flash, three second pause
Troubleshooting	Solution
<ol style="list-style-type: none"> Pressure switch tube blockage Faulty pressure switch 	<ol style="list-style-type: none"> Inspect pressure switch tube for blockage Do continuity test on pressure switch. If there is continuity, replace pressure switch. The hard lockout will require a manual power cycle of the control to clear the hard lockout.



PowerVent with Honeywell Electronic Control
(PowerVent ESII and PowerVent ESII with Electronic Control)

Error 45

Indications	Display
Recycle limit - PS/limit opened – Maximum number of retries has occurred. Unit is in hard lock-out.	Six-Two Flash, three second pause
Troubleshooting	Solution
<ol style="list-style-type: none"> 1. Check venting to insure pressure switch is not momentarily opening as the appliance warms. 2. Check vent outlet for wind-gust problems. 1. Check PS wiring. 2. Check PS rubber tube for blockage. 3. Check over temp switch. 4. Faulty pressure switch. 	<ol style="list-style-type: none"> 1. Correct any PVC vent issues. 2. Repair wiring or clear tube blockage. 3. Replace pressure switch. 3. The hard lockout will require a manual power cycle of the control to clear the hard lockout..

Error 46

Indications	Display
Pressure switch failed open (failed to close) – at the beginning of the heat cycle the control runs the inducer for 30 seconds waiting for the Pressure Switch to close. If the PS does not close in 30 seconds, the inducer turns off and the control flashes PS Failed Open error code. The control waits in this PS Failed Open mode for 2 minutes before turning on the inducer and trying for another 30 seconds to see the PS close. This cycle repeats for a maximum of five times before entering a hard lockout.	Three Flash, three second pause
Troubleshooting	Solution
<ol style="list-style-type: none"> 1. Vent blockage or improper installation 2. Switch tube blockage 3. Faulty pressure switch 4. Blower improper operation 5. Over temperature switch open <p>TIP: Rule out the water heater with the following process. Remove all PVC venting from the blower assy. Recycle water heater for main burner.</p> <ul style="list-style-type: none"> ü IF the water heater goes to main burner, then the water heater is not at fault. Check venting. ü IF the water heater does NOT go to main burner, then we have a part problem with 	<ol style="list-style-type: none"> 1. Inspect venting run for blockage 2. Verify over temp switch is cool to the touch 3. Inspect pressure switch tube for blockage 4. Check blower for proper operation 5. Replace pressure switch 6. The hard lockout will require a manual power cycle of the control to clear the hard lockout.



PowerVent with Honeywell Electronic Control
(PowerVent ESII and PowerVent ESII with Electronic Control)

Error 47

Indications	Display
Flammable vapor sensor lockout - The control immediately turns off all outputs (valves closed, inducer off, ignition off). Control enters hard lockout and registers Flammable Vapor Present error code.	Seven Flash, three second pause
Troubleshooting	Solution
<p>1. Gasoline or other flammable gas (hydrocarbons) was detected by the flammable vapor sensor.</p> 	<ol style="list-style-type: none"> 1. Check for flammable vapors around water heater 2. Verify FVS sensor resistance ~ 11 KΩ -45 KΩ 3. Replace FVS sensor if >45 KΩ 4. Reset gas control valve. Hard lockout to be cleared when the power is manually cycled, the control dial is rotated through the HOT setting 7 times within 30 seconds and the resistance of the sensor is within the normal operation range.

Error 49

Indications	Display
FVS fault detected - The control immediately turns off all outputs (valves closed, inducer off, ignition off) and enters Hardware Error Lockout and registers Flammable Vapor Device Interface/Miswiring error code.	Eight-One Flash, three second pause
Troubleshooting	Solution
<ol style="list-style-type: none"> 1. Flammable vapor sensor resistance is out of range (well below or well above parameters) 2. Wiring to FV sensor is faulty (open) 3. Gas control is faulty 	<ol style="list-style-type: none"> 1. Verify FVS sensor resistance ~ 11 KΩ -45 KΩ 2. Replace sensor and wiring harness. 3. Replace control if new sensor does not work. 4. Hard lockout will be cleared when the power is manually cycled, the control dial is rotated through the HOT setting 7 times within 30 seconds and the resistance of the sensor is within the normal operation range.



PowerVent with Honeywell Electronic Control
(PowerVent ESII and PowerVent ESII with Electronic Control)

Error 89

Indications	Display
Thermal well fault - Temperature Sensors not reading the same temperature within ± 5.5 °F (measure when water temperature is changing less than 1 °F/minute) - the control immediately turns off all outputs (valves closed, inducer off, ignition off) and enters Hardware Fault Lockout. Hardware Fault Lockout self clears if the fault clears for at least 15 seconds.	Eight-Two Flash, three second pause
Troubleshooting	Solution
1. Thermal well fault	3. Recycle power to verify error 4. Replace thermal well
2. Water temperature sensor fault. Measure the OHMS resistance between pins 1 and 2; then measure the resistance between pins 3 and 2. The two number should be the same. See chart on last page to convert OHMS to temperature.	5. Recycle power to verify error 6. Replace thermal well

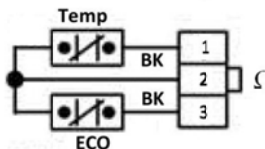

Error 91

Indications	Display
Communications Error- when display does not detect any gas control valve. User display is periodically checking the connection to the water heater.	None. Heater works without remote. This error code is for the display only.
Troubleshooting	Solution
1. Display and gas control valve are not talking to each other	1. Recycle power to verify error 2. Verify control molex correct at gas valve

Error 93

Indications	Display
Valve fault detected	Eight-Four Flash, three second pause
Troubleshooting	Solution
1. Gas control valve needs to be reset or has been damaged.	1. Recycle power to verify error 2. Replace gas control



**PowerVent with Honeywell Electronic Control
(PowerVent ESII and PowerVent ESII with Electronic Control)**

Reset Gas Control

This will clear the current fault and force the unit to recycle for ignition.

- 1. Turn temperature control knob all the way clockwise**
- 2. Recycle power to the heater (both blower and gas valve)**
- 3. Rotate the temp knob all the way to the left, then back to the right. You must cross the midline seven (7) times to reset the gas valve.**
- 4. Unit should return to normal operations if all faults have been cleared and repaired. You will hear the blower motor come on.**
- 5. Set water temperature to a safe setting of 120° or less.**

Replacing the Gas Control.

The electronic component for the gas valve is replaceable without draining the water from the tank. To replace just the electronic control portion:

- 1. Turn off the blower and the gas valve. Unplug the water heater.**
- 2. Remove wiring harnesses from the gas valve.**
- 3. Remove main burner supply tube and pilot supply tube.**
- 4. Remove / disconnect gas supply line.**
- 5. Grab the bottom of the gas valve (at the main burner supply tube area) and lift up and out at the same time. There are two small plastic locking tabs that will release.**
- 6. The electronic component will slide up and off the thermal well still installed in the tank.**
- 7. Replace the control in reverse order.**
- 8. Reconnect fuel supply lines and tubes.**
- 9. Reconnect wiring harnesses.**
- 10. Recycle power to the water heater.**
- 11. Set the water temperature not to exceed 120° F.**
- 12. Check for safe water heater operations.**

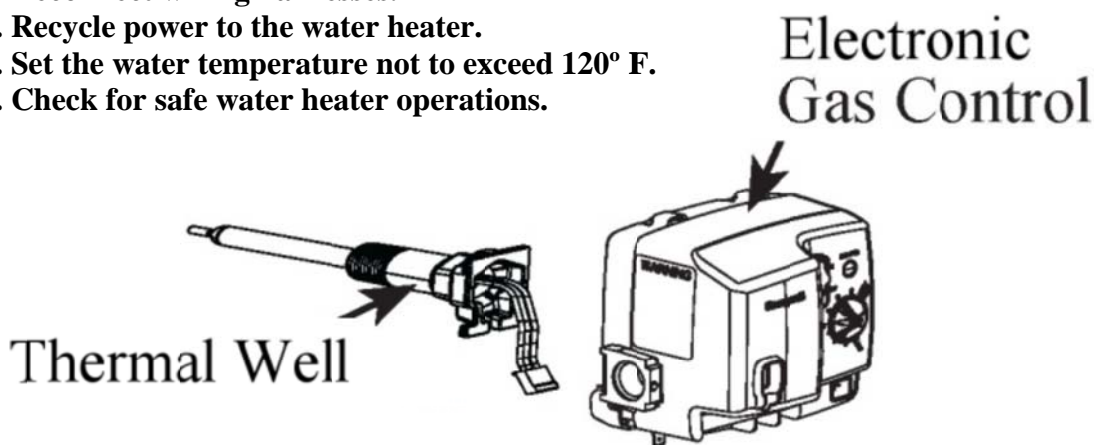



TECHNICAL SERVICE DEPARTMENT
Technical Service Bulletin
1-800-432-8373



PowerVent with Honeywell Electronic Control
(PowerVent ESII and PowerVent ESII with Electronic Control)

Temperature to Resistance Thermistor Chart 10KΩ Resistor

F°	Resistance
32	32,654
34	34,367
36	32,654
37	31,030
39	29,498
41	28,052
43	26,686
45	25,396
46	24,171
48	23,013
50	21,913
52	20,883
54	19,903
55	18,972
57	18,090
59	17,255
61	16,464
63	15,714
61	15,000
63	14,323
64	13,681
66	13,071
68	12,493
70	11,942
72	11,418
73	10,921
75	10,449
77	10,000
79	9,571
81	9,164
82	8,776
84	8,407
86	8,056
88	7,720
90	7,401

F°	Resistance
91	7,096
93	6,806
95	6,530
97	6,266
99	6,014
100	5,774
102	5,546
104	5,327
106	5,117
108	4,918
109	4,727
111	4,544
113	4,370
115	4,203
117	4,042
118	3,889
120	3,743
122	3,603
124	3,469
126	3,340
127	3,217
129	3,099
131	2,986
133	2,878
135	2,774
136	2,675
138	2,579
140	2,488
142	2,400
144	2,315
145	2,235
147	2,157
149	2,083
151	2,011

F°	Resistance
153	1,943
154	1,876
156	1,813
158	1,752
160	1,693
162	1,637
163	1,582
165	1,530
167	1,480
169	1,431
171	1,385
172	1,340
174	1,297
176	1,255
178	1,215
180	1,177
181	1,140
183	1,104
185	1,070
187	1,037
189	1,005
190	974
192	944
194	915
196	889
198	861
199	836
201	811
203	787
205	764
207	742
208	721
210	700
212	680



**PowerVent with Honeywell Electronic Control
 (PowerVent ESII and PowerVent ESII with Electronic Control)**

CONNECTION DIAGRAM

