



Witt

WT-ASL-0818A

Replaces WT-ASL-1112A and WT-ASE-0612A

ASLA/ALSE
**Slim-Temp Display Case
Unit Cooler**

Low and Medium Temperature
Reach-in Display Cases



Air Defrost
4,800 to 15,800 BTUH

Electric Defrost
4,600 to 15,000 BTUH



Slim-Temp

Features

The Slim-Temp ALSA / ASLE Display Case Unit Coolers are versatile products that are specifically designed for cooling reach-in display cases. Slim-Temp models are low height and compact. The slim profile takes up less room and maximizes available shelf space. Units are available with air or electric defrost, for low or medium temperature applications and are solidly built with heavy gauge aluminum housings.

Standard Features

- All models require externally equalized Thermostatic expansion valves
- ASLA capacity ratings at +25°F evaporator temperature
- ASLE capacity ratings at -10°F evaporator temperature.
- All Aluminum low silhouette housing
- Fan motors are totally enclosed, permanently lubricated and thermally protected

- Electrical connection made at internal terminal blocks located at end opposite refrigerant connections
- UL & cUL listed
- NSF approved

Optional Features

- Protective Russ-Proof epoxy coil coating extends the life of the coil

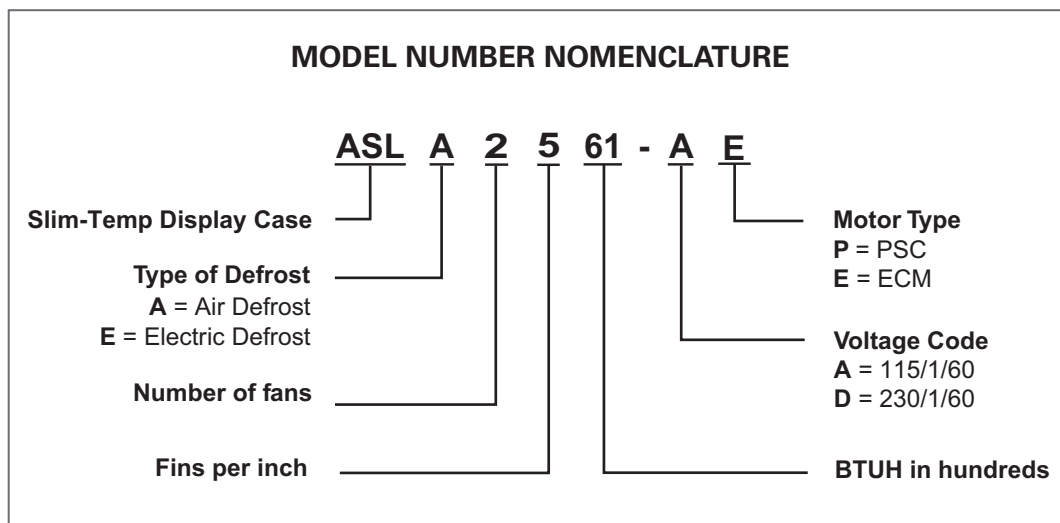

Performance and Specifications - Air Defrost Models

Model Number	BTUH Capacity @ 25°F S.T. & 10°F TD		CFM	Fan Motors	EC Motor Amps		Connections		Dimensions (Inches)*		Approx. Ship Wt. (Lbs.)
	R404A	R407A/ R448A/ R449A/B			115V	230V	Liquid	Suction	A	W	
ASLA 25-48	4,800	5,100	950	2-16 watt	1.16	0.58	1/2 FN	7/8 ODS	39	46-3/16	83
ASLA 25-61	6,400	6,900	1,000	2-16 watt	1.16	0.58	1/2 FN	7/8 ODS	49	56-3/16	105
ASLA 35-73	7,300	7,700	1,425	3-16 watt	1.74	0.87	1/2 FN	7/8 ODS	31	69-3/16	125
ASLA 45-98	9,800	10,700	1,900	4-16 watt	2.32	1.16	1/2 FN	1-1/8 ODS	28-1/4	92-3/16	151
ASLA 55-122	12,200	13,300	2,375	5-16 watt	2.9	1.45	1/2 FN	1-1/8 ODS	36	115-3/16	185
ASLA 65-158	15,800	17,300	2,850	6-16 watt	3.48	1.74	1/2 FN	1-1/8 ODS	32-3/4	138-3/16	222

* All dimensions are in inches.

Display Case Unit Cooler

Performance and Specifications - Electric Defrost Models

Model Number	BTUH Capacity @ 25°F S.T. & 10°F TD		CFM	Fan Motors	EC Motor Amps 230V	Connections		Dimension (Inches)*		Approx. Ship Wt. (Lbs.)
	R404A	R407A/ R448A/ R449A/B				Liquid	Suction	A	W	
ASLE 25-46	4,600	5,000	950	2-16 watt	0.58	1/2 FN	7/8 ODS	39	46-3/16	83
ASLE 25-58	5,800	6,300	1,000	2-16 watt	0.58	1/2 FN	7/8 ODS	49	56-3/16	105
ASLE 35-70	7,000	7,600	1,425	3-16 watt	0.87	1/2 FN	7/8 ODS	31	69-3/16	125
ASLE 45-94	9,400	10,100	1,900	4-16 watt	1.16	1/2 FN	1-1/8 ODS	28-1/4	92-3/16	151
ASLE 55-117	11,700	12,600	2,375	5-16 watt	1.45	1/2 FN	1-1/8 ODS	36	115-3/16	185
ASLE 65-150	15,000	16,200	2,850	6-16 watt	1.74	1/2 FN	1-1/8 ODS	32-3/4	138-3/16	222

* All dimensions are in inches.

Model Number	Heater 230V	
	Watts	Amps
ASLE 25-46	1,300	5.7
ASLE 25-58	1,970	8.6
ASLE 35-70	1,850	8.1
ASLE 45-94	2,400	10.5
ASLE 55-117	3,000	13.1
ASLE 65-150	3,500	15.2

Distributor Nozzle and Expansion Valves - Air Defrost Models

Model Number	Part Numbers						No. of Circuits
	R404A			R407A/ R448A/ R449A/B			
	Distributor @ 100°F & 50°F Liquid	Nozzle @ 100°F Liquid	Nozzle @ 50°F Liquid	Distributor @ 100°F & 50°F Liquid	Nozzle @ 100°F Liquid	Nozzle @ 50°F Liquid	
ASLA 25-48	-	-	-	-	-	-	1
ASLA 25-61	-	-	-	-	-	-	1
ASLA 35-73	-	-	-	-	-	-	1
ASLA 45-98	D260	L, #3/4	L, #1/4	D260	L, #3/4	L, #1/3	2
ASLA 55-122	D260	L, #1	L, #1/3	D260	L, #1	L, #1/3	2
ASLA 65-158	D260	L, #1-1/2	L, #1/2	D260	L, #1-1/2	L, #1/2	3

Distributor Nozzle and Expansion Valves - Electric Defrost Models

Model Number	Part Numbers						No. of Circuits
	R404A			R407A/ R448A/ R449A/B			
	Distributor @ 100°F & 50°F Liquid	Nozzle @ 100°F Liquid	Nozzle @ 50°F Liquid	Distributor @ 100°F & 50°F Liquid	Nozzle @ 100°F Liquid	Nozzle @ 50°F Liquid	
ASLE 25-46	D260	L, #3/4	L, #1/4	D260	L, #1/2	L, #1/4	2
ASLE 25-58	D260	L, #3/4	L, #1/3	D260	L, #3/4	L, #1/3	2
ASLE 35-70	D260	L, #1	L, #1/2	D260	L, #3/4	L, #1/2	3
ASLE 45-94	D260	L, #1-1/2	L, #3/4	D260	L, #1	L, #1/2	3
ASLE 55-117	D260	L, #1-1/2	L, #3/4	D260	L, #1-1/2	L, #3/4	4
ASLE 65-150	D262	L, #2	L, #1	D262	L, #2	L, #1	5

Slim-Temp

Physical Dimensions

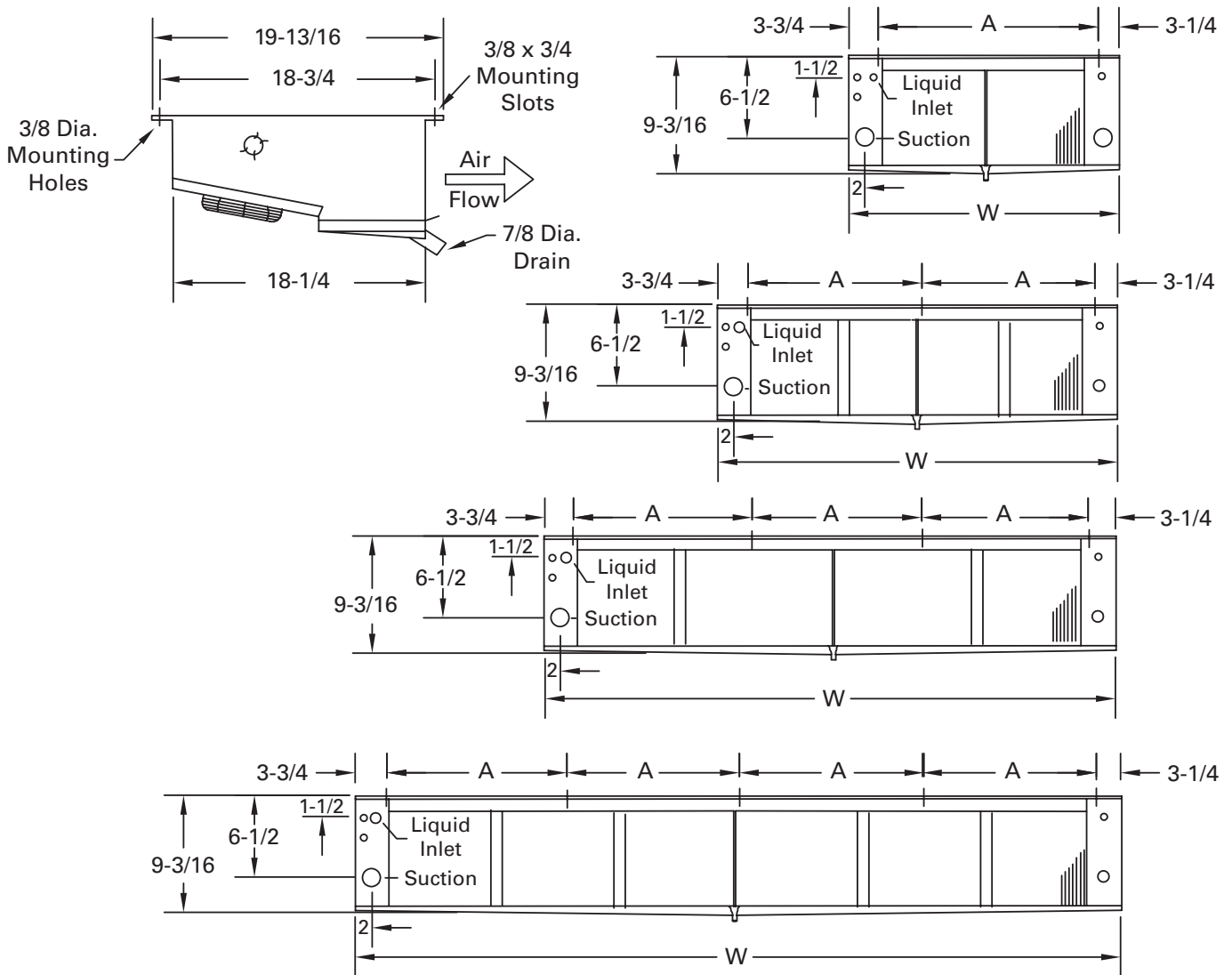

Due to continuing product development, specifications are subject to change without notice.

