

:: WELCOME TO THE REBIRTH OF COOL

The all-new Sure Comfort® Commercial Renaissance™ Line



*7.5–12.5 Ton
Cabinet is Shown*

7.5–12.5 Ton Package Air Conditioners
(RACDZT, RACDZS, RACDZR)

3–12.5 Ton Package Gas Electric Units
(RGEDZT, RGEDZS, RGEDZR, RGECZR)

7.5, 8.5 & 10 Ton Package Heat Pumps
(RHPDZT, RHPDZS)

.....
TRADE GUIDE

renaissance™

COMMERCIAL HVAC LINE

A revival of innovation and performance
in commercial HVAC.

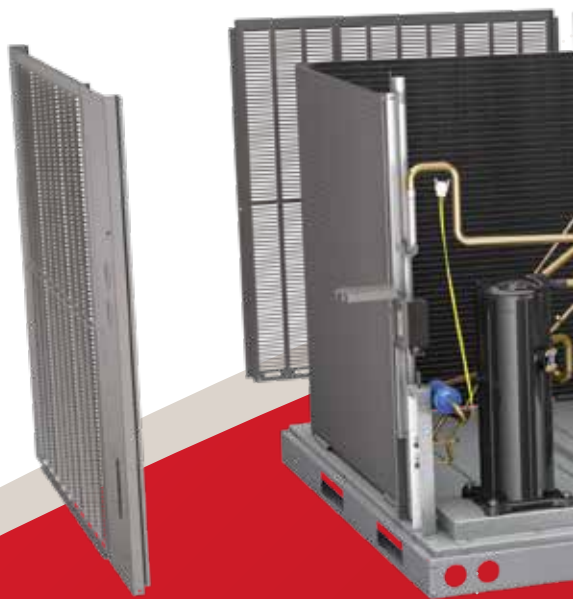

SOME MASTERPIECES ARE
MADE FROM PAINT OR
STONE. **OURS, FROM METAL.**

INTRODUCING THE SURE COMFORT® COMMERCIAL RENAISSANCE LINE—

the result of years of research and development, creative engineering and innovation. Made with smart new features and exclusive advantages—all delivered with renowned performance and dependability—the Renaissance Line is a signature piece offered by Sure Comfort from a growing portfolio of industry-leading, commercial HVAC solutions.



7.5–12.5 Ton Cabinet is Shown

TIER COMPARISON

Models	Single-Stage Cooling	Two-Stage Cooling	2018 DOE Efficiency Standards Compliant	2023 DOE Efficiency Standards Compliant	VFD Technology	HumidiDry™
Commercial Series (RACDZT, RGEDZT, RHPDZT)		✓	✓	✓	✓	Option
Commercial Series (RACDZS, RGEDZS, RHPDZS)		✓	✓		Option	Option
Commercial Series (RACDZR, RGEDZR, RGEZR)	✓		✓			

BASED ON SMART THINKING AND INVENTIVE PROBLEM SOLVING— **A REFINED SOLUTION TO ENHANCE PRODUCTIVITY.**



7.5–12.5 Ton Cabinet is Shown

Redesigned for today's demanding commercial applications, the Renaissance™ Line is packed with smart thinking—like high-quality critical components, lean manufacturing processes and robust design features—including the strengthened, solid, single-piece top, durable panels, plus Scroll™ compressor technology. Sure Comfort® offers inventive engineering that delivers easy installability, smart serviceability and industry-leading efficiencies for uptime dependability in a wide range of rooftop environments.

- Simple drop-in replacement—cutting installation time in half for substantial cost savings
- Build-to-order systems for all efficiency levels
- Commercial Series models are 2023 DOE Efficiency Standards Compliant right now
- First system in the dehumidification market with built-in Variable Frequency Drive (VFD)¹
- SmartShield™ Coil System Full MicroChannel Coil—an industry first for full indoor and outdoor MicroChannel Coils in commercial package heat pumps—decreases the amount of required refrigerant, connection brazing and overall weight
- SmartShield™ Coil System Heat Pump Defrost System virtually eliminates ice build-up²

:::PROVEN FASTER & EASIER SERVICEABILITY!

When performing industry-standard service & preventative maintenance, **the Renaissance Commercial Line reduces the service time by up to 100 minutes over other commercial HVAC brands.**³

¹VFD Technology and HumidiDry™ are available on ZS/ZT models, and will be available on 3–6 Ton ZR/ZS models in 2020. ²Available on 3–5 Ton Heat Pumps Only – coming Q4 2019. ³Per a MIAT Commercial HVAC Competitive Time Study, conducted June 4–6, 2019.



// **Simplicity** is the
ultimate sophistication. //

—Leonardo DaVinci //

THE ALL-NEW RENAISSANCE™ LINE. COMFORTABLY SMART.

Engineers were given a challenge: Build an innovative package rooftop product line to meet the new demands of a wide range of commercial applications. They delivered an inventive solution that improves every aspect, from replacement to dependability and from installability to serviceability.

SURE COMFORT DIAGNOSTICS

1

RENAISSANCE CORECOMMAND™ CONTROL

Dual 7-Segment LED Display delivers enhanced diagnostics with 43 easy-to-understand fault codes, complete fault history and input / output options to meet building compliance needs.

SMARTSHIELD™ COIL SYSTEM

2

ELECTROFIN® E-COAT PROCESS TECHNOLOGY

A factory-applied condenser coating that delivers superior corrosion resistance for indoor and outdoor coils to operate in the harshest of environments.

3

FULL MICROCHANNEL COIL

Full indoor and outdoor MicroChannel Coils maximize reliability while decreasing the amount of required refrigerant, connection brazing and overall weight. We're proud to offer the industry's first full indoor and outdoor MicroChannel Coil for commercial package heat pumps.¹

4

HEAT PUMP DEFROST SYSTEM¹

Rheem-exclusive, patent-pending Microchannel Defrost System that virtually eliminates ice build-up, preventing operation failure.

VELOCIFIN™²

5

HEAT EXCHANGER

A patent-pending, complete redesign of the heat exchanger tubing that meets customer and agency (AFUE, FER, ANSI Z21.47) requirements, and increases heat transfer through an innovative velocity concept—improving overall product efficiency.

6

SURE COMFORT HUMIDIDRY™

The first in the dehumidification market to incorporate a VFD that operates at a lower speed on first-stage cooling, saving energy, enhancing performance and increasing comfort.³

SERVICEMART

7

QWIK-CHANGE FLEX-FIT RACK

Allows easy changeover between 2" and 4" filters.

8

QWIK-SLIDE BLOWER ASSEMBLY

Extremely easy access and removal of blower assembly to service internal components.

9

QWIK-CLEAN DRAIN PAN

Composite material pan that slides out completely for easy cleaning and features a standard overflow sensor.

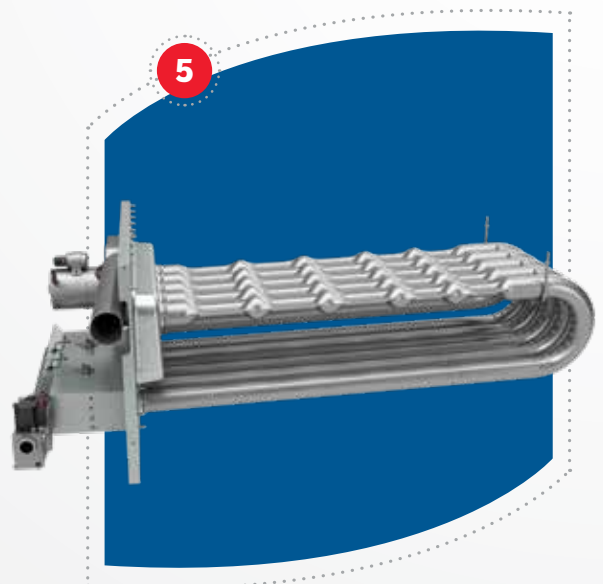



7.5–12.5 Ton Cabinet is Shown

NEW FEATURES

- 10** **EXTERNAL LOCKABLE GAUGE PORTS**
 Enables measuring pressures without opening the cabinet door and affecting unit performance.
- 11** **IMPROVED FOOTPRINT**
 Drop-in replacement cuts installation time in half for substantial cost savings.

¹Available on 3–5 Ton Heat Pumps Only – coming Q4 2019. ²Only applicable to 3–5 Ton Gas Electric models. ³HumidiDry is available on ZS/ZT models, and will be available on 3–6 Ton ZR/ZS models in 2020.



// Perfection is not when there is nothing left to add, but... nothing left to take away. **//**

—Antoine de Saint-Exupéry **//**

:: THE LEADING-EDGE OF EFFICIENCY— A NEW AGE IN SAVINGS.

Energy efficiency, savings, compliance and guarantees are important to you. That's why we had the Renaissance™ Line re-engineered from the ground up—all to meet the exacting standards of the industry as well as its customers. The Renaissance Line delivers a smart mixture of enhanced energy cost savings, available rebates, regulation compliance and an industry-leading warranty.

HIGH-EFFICIENCY SAVINGS

The Renaissance Line delivers improved energy savings of over 30% when compared to current baseline technology available in most commercial units operating in the marketplace—translating into savings of thousands of dollars over the life of the equipment.

CUSTOMIZED SOLUTIONS

The Renaissance Line offers a wide variety of heating and cooling solutions and build-to-order systems to suit the customer's business needs, design and application requirements—so there's no need to overpay for unnecessary "packages." The efficiency level and factory-installed options needed are chosen, with most factory-installed options and field-installed accessories available across all product tiers*—so customers get a customized solution to suit their business needs.

REBATE OPPORTUNITY

With industry-leading efficiencies of up to 14.8 IEER, the Renaissance Line may qualify for a variety of utility rebates—helping business customers realize substantial savings for a greater return on their investment, at purchase and year after year.



7.5–12.5 Ton
Cabinet is Shown

**VFD Technology is not available on ZR models. HumidiDry is available on ZS/ZT models, and will be available on 3–6 Ton ZR/ZS models in 2020.*

:: VISIONARY FORM MEETS FLEXIBLE FUNCTION.

From new construction to replacement projects and more, the new Sure Comfort® Commercial Renaissance™ Line offers a variety of commercial heating and cooling products that meet all design and application requirements. Whether your customers are retail, hotels, restaurants, offices, schools, senior care or gyms, you can connect a new, customized Renaissance unit quickly and efficiently—providing comfort and peace-of-mind.

DOE EFFICIENCY STANDARDS COMPLIANT (2018 & 2023)

Loaded with innovative and improved technologies for compliance with the Department of Energy's (DOE) new IEER standards effective as of January 2018—plus, Sure Comfort is ready RIGHT NOW for 2023 regulations.

CALIFORNIA TITLE 24 / ASHRAE 90.1 COMPLIANT

Achieves advanced energy efficiency and performance with our exclusive features to meet ASHRAE 90.1-2007†; ASHRAE 90.1-2013, ASHRAE 62.1 and California Title 24 regulations.

GUARANTEED PERFORMANCE

Industry-leading commercial limited warranty includes:

- Stainless Steel Heat Exchanger – 20 Years
- Aluminized Heat Exchanger – 10 Years
- Scroll™ Compressor – 5 Years
- All Other Parts – 1 Year

**Applies to RGEDZR, RACDZR and RHPDZR models only*

PACKAGE AIR CONDITIONERS

COOLING DATA						HEAT INPUT		PHYSICAL DATA	
Model	Nominal Tonnage	Gross Capacity (BTUH)	AHRI Rated Net Capacity (BTUH)	Nominal CFM/AHRI (CFM)	IEER	Low	High	Dimensions H x W x L (inches)	Shipping Weight (lbs)
RACDZR090	7.5	88,000	85,000	3,000/3,175	12.9	N/A	N/A	50 x 58 x 89	775
RACDZR102	8.5	99,000	96,000	3,400/3,200	12.9	N/A	N/A	50 x 58 x 89	801
RACDZR120	10	118,000	114,000	4,000/3,480	12.9	N/A	N/A	50 x 58 x 89	830
RACDZS090	7.5	88,000	85,000	3,000/3,200	12.9	N/A	N/A	50 x 58 x 89	775
RACDZS102	8.5	99,000	96,000	3,400/3,225	12.9	N/A	N/A	50 x 58 x 89	801
RACDZS120	10	118,000	114,000	4,000/3,480	12.9	N/A	N/A	50 x 58 x 89	830
RACDZS150	12.5	148,000	142,000	5,000/4,150	12.4	N/A	N/A	60 x 58 x 89	1,032
RACDZT090	7.5	88,000	85,000	3,000/3,200	14.8	N/A	N/A	50 x 58 x 89	775
RACDZT102	8.5	99,000	96,000	3,400/3,225	14.8	N/A	N/A	50 x 58 x 89	801
RACDZT120	10	118,000	114,000	4,000/3,480	14.8	N/A	N/A	50 x 58 x 89	830
RACDZT150	12.5	148,000	142,000	5,000/4,150	14.2	N/A	N/A	60 x 58 x 89	1,032

COMMERCIAL PRODUCT SPECIFICATIONS

PACKAGE GAS ELECTRIC UNITS

COOLING DATA						HEAT INPUT		PHYSICAL DATA	
Model	Nominal Tonnage	Gross Capacity (BTUH)	AHRI Rated Net Capacity (BTUH)	Nominal CFM/AHRI (CFM)	IEER	Standard (BTUH)	High (BTUH)	Dimensions H x W x L (inches)	Shipping Weight (lbs)
RGECZR036	3.0	36,000	35,400	1,200/1,300	N/A	75,000	52,500	41 x 45 x 78	645
RGECZR048	4.0	48,000	47,500	1,600/1,730	N/A	75,000	52,500	41 x 45 x 78	668
RGECZR060	5.0	60,000	57,500	2,000/1,950	N/A	75,000	52,500	41 x 45 x 78	671
RGEDZR090**15	7.5	88,000	85,000	3,000/3,175	12.7	105,000	150,000	50 x 58 x 89	878
RGEDZR090**20	7.5	88,000	85,000	3,000/3,175	12.7	143,000	205,000	50 x 58 x 89	878
RGEDZR102**15	8.5	99,000	96,000	3,400/3,200	12.7	105,000	150,000	50 x 58 x 89	907
RGEDZR102**22	8.5	99,000	96,000	3,400/3,200	12.7	157,500	225,000	50 x 58 x 89	907
RGEDZR120**15	10	118,000	114,000	4,000/3,480	12.7	105,000	150,000	50 x 58 x 89	935
RGEDZR120**22	10	118,000	114,000	4,000/3,480	12.7	157,500	225,000	50 x 58 x 89	935
RGEDZS090**15	7.5	88,000	85,000	3,000/3,175	12.7	105,000	150,000	50 x 58 x 89	878
RGEDZS090**22	7.5	88,000	85,000	3,000/3,175	12.7	143,000	205,000	50 x 58 x 89	878
RGEDZS102**15	8.5	99,000	96,000	3,400/3,225	12.7	105,000	150,000	50 x 58 x 89	907
RGEDZS102**22	8.5	99,000	96,000	3,400/3,225	12.7	157,500	225,000	50 x 58 x 89	907
RGEDZS120**15	10	118,000	114,000	4,000/3,480	12.7	105,000	150,000	50 x 58 x 89	935
RGEDZS120**22	10	118,000	114,000	4,000/3,480	12.7	157,000	225,000	50 x 58 x 89	935
RGEDZS150**15	12.5	148,000	142,000	5,000/3,750	12.2	105,000	150,000	60 x 58 x 89	1,133
RGEDZS150**22	12.5	148,000	142,000	5,000/3,750	12.2	157,500	225,000	50 x 58 x 89	1,133
RGEDZT090**15	7.5	88,000	85,000	3,000/3,175	14.6	105,000	150,000	50 x 58 x 89	878
RGEDZT090**20	7.5	88,000	85,000	3,000/3,175	14.6	143,000	205,000	50 x 58 x 89	878
RGEDZT102**15	8.5	99,000	96,000	3,400/3,225	14.6	105,000	150,000	50 x 58 x 89	907
RGEDZT102**22	8.5	99,000	96,000	3,400/3,225	14.6	157,500	225,000	50 x 58 x 89	907
RGEDZT120**15	10	118,000	114,000	4,000/3,480	14.6	105,000	150,000	50 x 58 x 89	935
RGEDZT120**22	10	118,000	114,000	4,000/3,480	14.6	157,500	225,000	50 x 58 x 89	935
RGEDZT150**15	12.5	148,000	142,000	5,000/3,750	14	105,000	150,000	60 x 58 x 89	1,133
RGEDZT150**22	12.5	148,000	142,000	5,000/3,750	14	157,500	225,000	60 x 58 x 89	1,133

PACKAGE HEAT PUMPS

COOLING DATA						HEAT INPUT				PHYSICAL DATA	
Model	Nominal Tonnage	Gross Capacity (BTUH)	AHRI Rated Net Capacity (BTUH)	Nominal CFM/AHRI (CFM)	IEER	47 Capacity	Cop 47 Efficiency	17 Capacity	Cop 17 Efficiency	Dimensions H x W x L (inches)	Shipping Weight (lbs)
RHPDZS102A	8.5	101,000	98,000	3,400/3,345	12.2	98,000	3.3	60,000	2.3	50 x 58 x 89	850-861
RHPDZS120A	10	119,000	114,000	4,000/4,060	12.2	114,000	3.3	72,000	2.3	50 x 58 x 89	902-913
RHPDZT090A	7.5	89,000	86,000	3,000/3,030	14.1	86,000	3.4	48,000	2.3	50 x 58 x 89	814-825
RHPDZT102A	8.5	101,000	98,000	3,400/3,345	14.1	98,000	3.4	60,000	2.3	50 x 58 x 89	850-861
RHPDZT120A	10	119,000	114,000	4,000/4,060	14.1	114,000	3.4	72,000	2.3	50 x 58 x 89	902-913

:: CUSTOMIZED SOLUTIONS TO HELP
GROW YOUR BUSINESS.



FLEXIBLE PRODUCT OPTIONS

The Sure Comfort® Renaissance™ Line is full of smart options and must-have accessories, which can be factory- or field-installed—so your customers get a customized solution to suit their business needs.

FASTER LEAD TIME

With a redesigned, technologically advanced commercial production facility, it's easy to take advantage of improved factory lead times on build-to-order systems with custom options to help avoid business downtime.

SURE COMFORT *COMMERCIAL KWIKCOMFORT® FINANCING*

The Sure Comfort brand has partnered with Fernwood Capital to offer customized financing plans that meet the specific needs of the customer, allowing them to obtain commercial equipment, with total project costs of \$5,000–\$3 million, that will help build their continued business growth.

SURE COMFORT PROTECTION PLUS® PLANS

We offer an ever-expanding range of Sure Comfort partnered with AIG® to offer parts and labor extended service agreements, for commercial applications that allow you to provide customers with a full-service, world-class solution for their long-term HVAC needs.



WIDE PRODUCT AVAILABILITY ACROSS THE UNITED STATES AND CANADA

Sure Comfort offers an ever-expanding range of heating & cooling solutions, plus distribution in US and Canada, making it easy to get the right product at the right time and in the right place, driving uptime for your business.

:: WHY SURE COMFORT® COMMERCIAL?



Sure Comfort takes pride in putting real people and results first. In addition to the all-new Renaissance™ Line, the brand offers durable residential and commercial HVAC products to meet a wide range of market needs and standards. From easy-service features and a variety of capacities to exclusive training and marketing tools—you can easily provide a dependable comfort system for your customers.

Sure Comfort History. A trusted brand name, Sure Comfort offers dependable HVAC equipment for homes and businesses. From our products, to our people, to our brand promise, we put substance before style and real results before anything else.

// Recognizing the need is the primary condition for design.

—Charles Eames



SURE COMFORT-OWNED SELECTION TOOL SOFTWARE

Sure Comfort offers a free software portfolio developed with easy-to-use, smart selection tools you need to specify, select and document all Sure Comfort equipment, including factory-installed options and field-installed accessories, for all commercial applications.



BAS/EMS COMPATIBLE (BUILDING AUTOMATION SYSTEM / ENERGY MANAGEMENT SYSTEM)

Every product in the Renaissance Line offers the latest in comfort management technology. Factory-installed ClearControl™ Direct Digital Control (DDC) and sensors can connect to LonWorks™, BACnet® and Modbus® BAS/EMS systems for remote monitoring and precise control—allowing faster problem solving if service is ever required. They also help the unit operate more efficiently and reduce energy costs.



BIM SUPPORT

Sure Comfort offers a comprehensive engineering documentation and imagery content database, so you can more accurately design and estimate job costs in less time. This includes spec data, 2- and 3-D CAD® files and Revit® files that are BIM software compatible.



DEDICATED TECHNICAL SUPPORT

Uptime is critical to your business customers. That's why there is a dedicated Support Team standing by to answer your questions—plus with resources such as MySureComfort.com, our Innovative Learning Centers, live product assistance and more, we're here to support you at every step.

:: READY TO HELP YOUR CUSTOMERS CREATE THEIR NEXT COMMERCIAL MASTERPIECE?

No matter what project you need to spec, the Renaissance™ Line offers you the best fit for commercial rooftop applications—delivering masterful performance, easy installability and smart serviceability—plus, industry-leading efficiencies and the renowned Sure Comfort® dependability you trust.

Visit [SureComfort.com/Renaissance](https://www.surecomfort.com/Renaissance) today.

In keeping with its policy of continuous progress & program improvement, Sure Comfort reserves the right to make changes without notice.