

:: WELCOME TO THE REBIRTH OF COOL

The all-new Sure Comfort® Commercial Renaissance™ Line



*7.5–12.5 Ton
Cabinet is Shown*

7.5–12.5 Ton Package Air Conditioners
(RACDZT, RACDZS, RACDZR)

3–12.5 Ton Package Gas Electric Units
(RGEDZT, RGEDZS, RGEDZR, RGECZR)

7.5, 8.5 & 10 Ton Package Heat Pumps
(RHPDZT, RHPDZS)

.....
COMMERCIAL CUSTOMER GUIDE

renaissance™

COMMERCIAL HVAC LINE

A revival of innovation and performance
in commercial HVAC.



SOME MASTERPIECES ARE
MADE FROM PAINT OR
STONE. **OURS, FROM METAL.**

INTRODUCING THE SURE COMFORT® COMMERCIAL RENAISSANCE LINE—
the result of years of research and development, creative engineering and innovation.
Made with smart new features and exclusive advantages—all delivered with renowned
performance and dependability—the Renaissance Line is a signature piece offered by
Sure Comfort from a growing portfolio of industry-leading, commercial HVAC solutions.



7.5–12.5 Ton
Cabinet is Shown

TIER COMPARISON

Models	Single-Stage Cooling	Two-Stage Cooling	VFD Technology	HumidiDry™
Commercial Series (RACDZT, RGEDZT, RHPDZT)		✓	✓	Option
Commercial Series (RACDZS, RGEDZS, RHPDZS)		✓	Option	Option
Commercial Series (RACDZR, RGEDZR, RGEZR)	✓			

A REFINED SOLUTION TO MAKE REPLACEMENT, INSTALLATION AND SERVICE FASTER AND EASIER.



7.5–12.5 Ton Cabinet is Shown

Redesigned for today's demanding commercial applications, the Renaissance™ Line is packed with smart thinking—like high-quality critical components, lean manufacturing processes and robust design features—including the strengthened, solid, single-piece top, durable panels, plus Scroll™ compressor technology. Sure Comfort® offers inventive engineering that delivers easy installability, smart serviceability and industry-leading efficiencies for uptime dependability in a wide range of rooftop environments.

- Simple drop-in replacement—cutting installation time in half for substantial cost savings
- Build-to-order systems for all efficiency levels
- Commercial Series models are 2023 DOE Efficiency Standards Compliant right now
- First system in the dehumidification market with built-in Variable Frequency Drive (VFD)¹
- SmartShield™ Coil System Full MicroChannel Coil – an industry first for full indoor and outdoor MicroChannel Coils in commercial package heat pumps maximizes reliability
- SmartShield™ Coil System Heat Pump Defrost System eliminates ice build-up for maximum reliability²

::PROVEN FASTER & EASIER SERVICEABILITY!

When performing industry-standard service & preventative maintenance, the Renaissance Commercial Line reduces the service time by up to 100 minutes over other commercial HVAC brands.³ And that can mean lower service costs for your business.

¹VFD Technology and HumidiDry™ are available on ZS/ZT models, and will be available on 3–6 Ton ZR/ZS models in 2020. ²Available on 3–5 Ton Heat Pumps Only – coming Q4 2019. ³Per a MIAT Commercial HVAC Competitive Time Study, conducted June 4–6, 2019.



// **Simplicity** is the
ultimate sophistication. //

—Leonardo DaVinci //

THE ALL-NEW RENAISSANCE™ LINE. COMFORTABLY SMART.

Engineers were given a challenge: Build an innovative package rooftop product line to meet the new demands of a wide range of commercial applications. They delivered an inventive solution that improves every aspect, from replacement to dependability and from installability to serviceability.

SURE COMFORT DIAGNOSTICS

1

RENAISSANCE CORECOMMAND™ CONTROL

Dual 7-Segment LED Display delivers enhanced diagnostics with 43 easy-to-understand fault codes, complete fault history and input / output options to meet building compliance needs.

2

ELECTROFIN® E-COAT PROCESS TECHNOLOGY

A factory-applied condenser coating that delivers superior corrosion resistance for indoor and outdoor coils to operate in the harshest of environments.

3

FULL MICROCHANNEL COIL

Full indoor and outdoor MicroChannel Coils maximize reliability while decreasing the amount of required refrigerant, connection brazing and overall weight. We're proud to offer the industry's first full indoor and outdoor MicroChannel Coil for commercial package heat pumps.

4

HEAT PUMP DEFROST SYSTEM¹

Rheem-exclusive, patent-pending Microchannel Defrost System that virtually eliminates ice build-up, preventing operation failure.

5

VELOCIFIN™²

HEAT EXCHANGER

A patent-pending, complete redesign of the heat exchanger tubing that meets customer and agency (AFUE, FER, ANSI Z21.47) requirements, and increases heat transfer through an innovative velocity concept—improving overall product efficiency.

6

SURE COMFORT HUMIDIDRY™

The first in the dehumidification market to incorporate a VFD that operates at a lower speed on first-stage cooling, saving energy, enhancing performance and increasing comfort.³

7

QWIK-CHANGE FLEX-FIT RACK

Allows easy changeover between 2" and 4" filters.

8

QWIK-SLIDE BLOWER ASSEMBLY

Extremely easy access and removal of blower assembly to service internal components.

9

QWIK-CLEAN DRAIN PAN

Composite material pan that slides out completely for easy cleaning and features a standard overflow sensor.

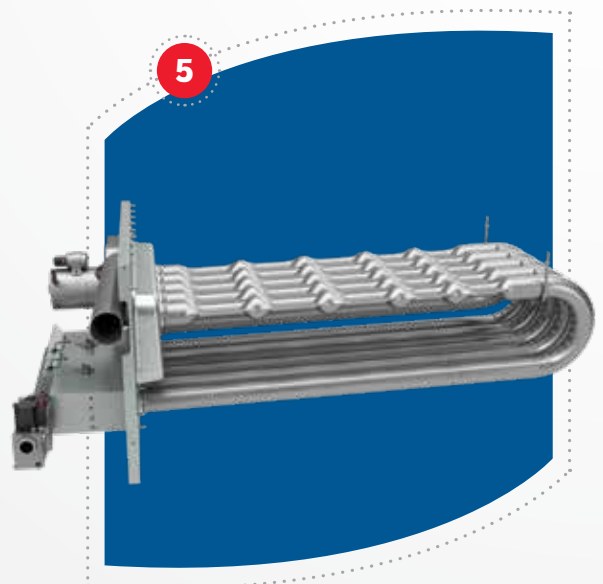



7.5–12.5 Ton Cabinet is Shown

NEW FEATURES

- 10** **EXTERNAL LOCKABLE GAUGE PORTS**
 Enables measuring pressures without opening the cabinet door and affecting unit performance.
- 11** **IMPROVED FOOTPRINT**
 Drop-in replacement cuts installation time in half for substantial cost savings.

¹Available on 3–5 Ton Heat Pumps Only – coming Q4 2019. ²Only applicable to 3–5 Ton Gas Electric models. ³HumidiDry is available on ZS/ZT models, and will be available on 3–6 Ton ZR/ZS models in 2020.



// Perfection is not when there is nothing left to add, but... nothing left to take away. **//**

—Antoine de Saint-Exupéry **//**

:: THE LEADING-EDGE OF EFFICIENCY— A NEW AGE IN SAVINGS.

Energy efficiency, savings, compliance and guarantees are important to you. That's why we had the Renaissance™ Line re-engineered from the ground up—all to meet the exacting standards of the industry as well as its customers. The Renaissance Line delivers a smart mixture of enhanced energy cost savings, available rebates, regulation compliance and an industry-leading warranty.

HIGH-EFFICIENCY SAVINGS

The Renaissance Line delivers improved energy savings of over 30% when compared to current baseline technology—translating into savings of thousands of dollars over the life of the equipment.

CUSTOMIZED SOLUTIONS

The Renaissance Line offers a wide variety of heating and cooling solutions and build-to-order systems to suit your business needs, design and application requirements—eliminating the need to overpay for unnecessary “packages,” so you get a customized solution to suit your business needs.

REBATE OPPORTUNITY

With industry-leading efficiencies of up to 14.8 IEER, the Renaissance Line may qualify for a variety of utility rebates—helping your business realize substantial savings for a greater return on investment, at purchase and year after year.



7.5–12.5 Ton
Cabinet is Shown

:: VISIONARY FORM MEETS FLEXIBLE FUNCTION.

From new construction to replacement projects and more, the new Sure Comfort® Commercial Renaissance™ Line offers a variety of commercial heating and cooling products that meet all design and application requirements. Whether your customers are retail, hotels, restaurants, offices, schools, senior care or gyms, you can have a new, customized Renaissance unit connected quickly and efficiently—providing comfort and peace-of-mind.



DOE EFFICIENCY STANDARDS COMPLIANT (2018 & 2023)

Loaded with innovative and improved technologies for compliance with the Department of Energy's (DOE) new IEER standards effective as of January 2018—plus, Renaissance is ready RIGHT NOW for 2023 regulations.

CALIFORNIA TITLE 24 / ASHRAE 90.1 COMPLIANT

Achieves advanced energy efficiency and performance with our exclusive features to meet ASHRAE 90.1-2007*, ASHRAE 90.1-2013, ASHRAE 62.1 and California Title 24 regulations.

GUARANTEED PERFORMANCE

Industry-leading commercial limited warranty includes:

- Stainless Steel Heat Exchanger – 20 Years
- Aluminized Heat Exchanger – 10 Years
- Scroll™ Compressor – 5 Years
- All Other Parts – 1 Year

*Applies to RGEDZR, RACDZR and RHPDZR models only

THE RENAISSANCE LINE— ENGINEERED FOR ALL COMMERCIAL APPLICATIONS

The new Sure Comfort Commercial Renaissance Line is redesigning performance for commercial applications. Highlights include:



Hotels / Hospitality

For hotels, resorts and casinos, consistent guest service and climate control is a top priority. The Renaissance Line is the perfect choice for a highly efficient heating and cooling system—all BAS/EMS compatible to deliver comfort, control and savings you can count on.



Restaurants / Foodservice

In the food business, uptime is critical. The Renaissance Line simplifies the replacement process with an improved product footprint, cutting installation time in half for substantial cost savings.



Office Buildings

Maximum business productivity demands cost-conscious comfort and control year-round. The Renaissance Line offers BAS/EMS compatibility and smart energy savings of over 30% compared to baseline technology—which can translate into thousands of dollars added to the bottom line.



Schools

From daycare to higher education, campuses must meet high standards of cleanliness and comfort. The Renaissance Line's smart features and BAS/EMS compatibility cut energy use and costs to help fund infrastructure repairs, construction rebuilds and remodeling projects.



Senior Care Centers

To help enrich the lives of our elders, facilities need precise and reliable climate control that provides better comfort and still meets tight budgets. The new Renaissance Line is the best match for good business—designed to be easy to install, maintain and service to deliver low lifecycle costs.



Athletic Facilities / Gyms

For workout facilities, precise climate control to keep members cool and comfortable is key. The Renaissance Line features HumidiDry™* technology, the first in the dehumidification market with built-in VFD—saving energy, enhancing performance and increasing comfort.



Retail Environments

From smaller stores to big box supercenters, guest comfort is critical, but so is watching overhead costs. The Renaissance Line delivers a smart mix of enhanced energy cost savings, available rebates, regulation compliance, plus an industry-leading limited warranty to minimize lifecycle costs.

** HumidiDry is available on ZS/ZT models, and will be available on 3–6 Ton ZR/ZS models in 2020.*

:: CUSTOMIZED SOLUTIONS TO HELP
GROW YOUR BUSINESS.



7.5–12.5 Ton
Cabinet is Shown

FLEXIBLE PRODUCT OPTIONS

The Sure Comfort® Renaissance™ Line is full of smart options and must-have accessories, which can be factory- or field-installed—so you get a customized solution to suit your business needs.

FASTER LEAD TIME

With a redesigned, technologically advanced commercial production facility, we make it easy to take advantage of improved factory lead times on build-to-order systems with custom options to help avoid business downtime.

SURE COMFORT *COMMERCIAL KWIKCOMFORT® FINANCING*

The Sure Comfort brand has partnered with Fernwood Capital to offer customized financing plans that meet your specific needs that will facilitate your continued business growth.

SURE COMFORT PROTECTION PLUS® PLANS

We have partnered with AIG® to offer parts and labor extended service agreements, for commercial applications that allow you to prepare for unexpected and unbudgeted repairs.



WIDE PRODUCT AVAILABILITY ACROSS THE UNITED STATES AND CANADA

We offer an ever-expanding range of Sure Comfort heating & cooling solutions, plus distribution in US and Canada, making it easy to get the right product at the right time and in the right place, driving uptime for your business.

:: WHY SURE COMFORT® COMMERCIAL?



With the addition of the all-new Renaissance™ Line, Sure Comfort® delivers a wide range of efficient, dependable and cost-effective commercial heating and cooling options—so businesses can optimize indoor environments, as well as budgets. From advanced technologies and easy-service features to industry-leading innovation, our commercial products deliver durable, long-lasting performance to get the job done every day.

Sure Comfort History. A trusted brand name from an industry leader, Sure Comfort offers dependable HVAC equipment for homes and businesses. From our products, to our people, to our brand promise, we put substance before style and real results before anything else.

// Recognizing the need is the primary condition for design.

—Charles Eames //



BAS/EMS COMPATIBLE (BUILDING AUTOMATION SYSTEM / ENERGY MANAGEMENT SYSTEM)

Every product in the Renaissance Line offers the latest in comfort management technology. Factory-installed ClearControl™ Direct Digital Control (DDC) and sensors can connect to LonWorks™, BACnet® and Modbus® BAS/EMS systems for remote monitoring and precise control—allowing faster problem solving if service is ever required. They also help the unit operate more efficiently and reduce energy costs.



EXPEDITED DELIVERY & INSTALL

To keep your business running, you can rest assured that contractors can get the product you need quickly. Plus, the Renaissance Line was designed with innovative features that simplify installation and serviceability—so for new construction, replacement or maintenance, we've made sure to minimize downtime.



DEDICATED TECHNICAL SUPPORT

Uptime is critical to your business. That's why we offer a dedicated Support Team standing by to answer your questions and support you at every step.

:: READY TO REPLACE YOUR OLD HVAC WITH A COMMERCIAL MASTERPIECE?

No matter the condition of your current units or type of business, the Renaissance™ Line offers you the best replacement for commercial rooftop applications—delivering easy installability, masterful performance and smart serviceability—plus, industry-leading efficiencies and the renowned Sure Comfort® dependability you trust.

Visit [SureComfort.com/Renaissance](https://www.surecomfort.com/Renaissance) today.

In keeping with its policy of continuous progress & program improvement, Sure Comfort reserves the right to make changes without notice.