

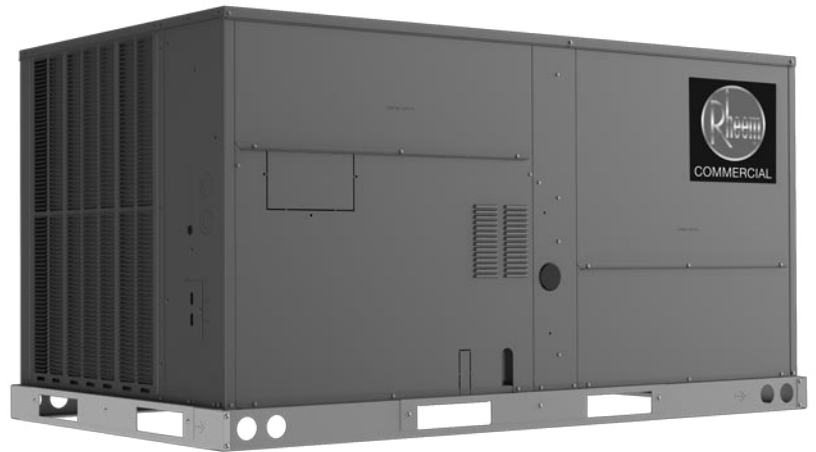

The new degree of comfort.™

## Commercial Renaissance™ Line Package Heat Pumps



### **RHPCZT Commercial *Prestige*® Series**

Nominal Size 6 Tons

ASHRAE 90.1 2019 Compliant Models

### **RHPCZR Commercial *Classic*® Series**

Nominal Sizes 3, 4 & 5 Tons

ASHRAE 90.1 2019 Compliant Models



## TABLE OF CONTENTS

Unit Features & Benefits .....	3-9
Model Number Identification .....	10
Options .....	11
General Data.....	12-17
General Data Notes .....	18
Weighted Sound Power .....	19
Gross Systems Performance Data .....	20-27
Airflow Performance Data .....	28-31
Electrical Data.....	32-37
Dimensional Data .....	38-40
Field-Installed Accessories.....	41-59
Guide Specifications .....	60-66
Limited Warranty .....	67

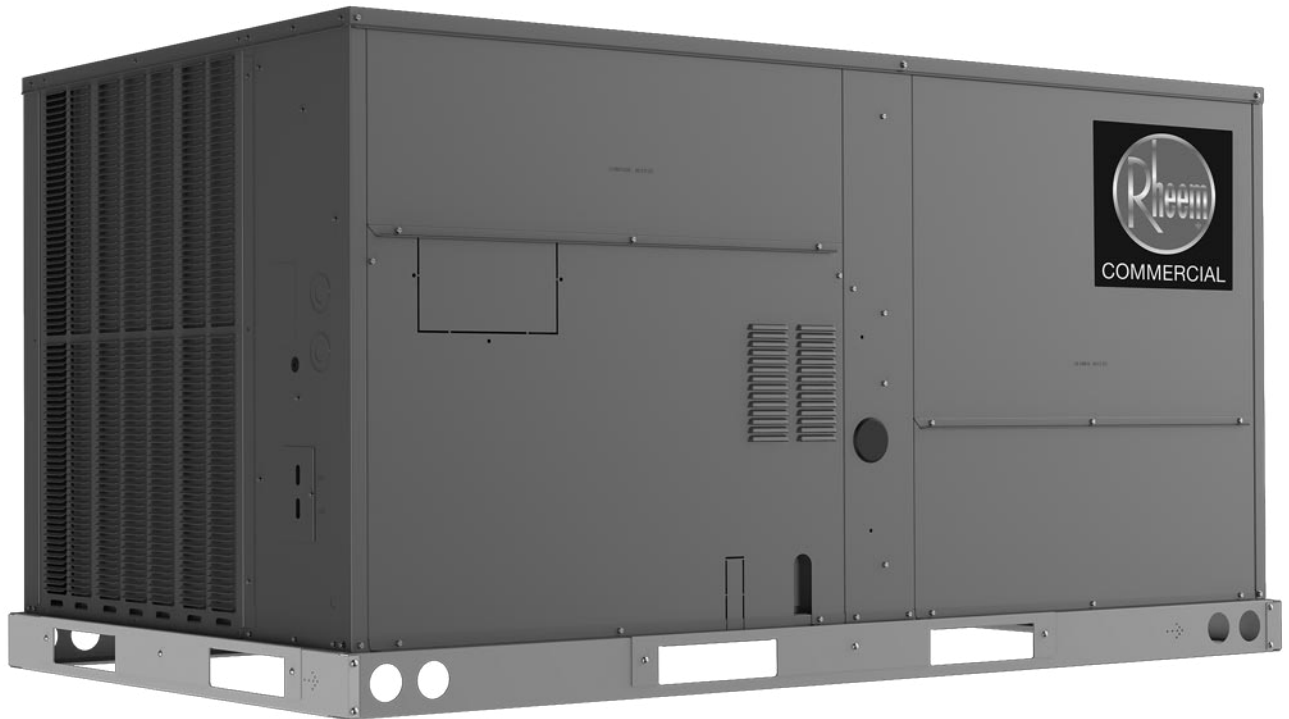

## RHPC STANDARD FEATURES INCLUDE:

- Factory charged with R-410A HFC refrigerant
- Wired and run tested
- Scroll compressors with internal line break overload and high pressure protection
- Convertible airflow – vertical down flow or horizontal side flow
- Forkable base rails for easy handling and lifting
- Cooling operation up to 125°F ambient
- MicroChannel evaporator and condenser coil
- PlusOne® ServiceSmart package includes:  
 Qwik-Change Flex-Fit Rack™  
 Qwik-Slide Blower Assembly™  
 Qwik-Clean Drain Pan™
- Over-flow condensate sensor
- PlusOne® Diagnostics with Dual 7-Segment LED Display to meet code compliance
- One-piece top cover and base pan with drawn supply and return opening
- Two-piece control door
- ¼ turn fasteners on filter access door
- Color-coded and labeled wiring
- External lockable gauge ports
- TXV refrigerant metering system
- Solid-core liquid line filter drier
- High pressure and low pressure/loss of charge protection with built-in Smart Logic
- Insulation encapsulated throughout entire unit
- New product footprint with matching connections
- Improved factory lead times
- 6 Ton includes a single 2-Stage compressor
- 3-5 Ton includes one single-stage compressor
- MERV 8 & MERV 13 filters are available as an accessory
- Standard Modbus interface



## FACTORY INSTALLED OPTIONS:

- Louvered panels
- Hinged access doors
- Low ambient/freeze stat
- Non-powered convenience outlet
- Economizer (Title 24 and ASHRAE 90.1 2019 compliant)
- Supply smoke detector

- Return smoke detector
- ElectroFin® E-Coat for Microchannel Condenser Coil Coating
- ClearControl™ Direct Digital Control (DDC)
- Comfort Alert Phase-monitor Protection
- Vertical Economizer

## FIELD INSTALLED ACCESSORIES:

Accessory	Model Number	Factory Installation Available?
Economizer w/Single Enthalpy (Downflow/Vertical)	RXRD-01MCDAM3	Yes
Economizer w/Single Enthalpy (Horizontal)	RXRD-01MCHAM3	No
Economizer-w/Single Enthalpy (Downflow/Vertical) DDC	RXRD-01MCDBM3	Yes
Economizer w/Single Enthalpy (Horizontal) DDC	RXRD-01MCHBM3	No
Dual Enthalpy Kit	RXXR-BV01	No
Dual Enthalpy Kit DDC	RXXR-BV02	No
Power Exhaust (230V) Vertical	RXXR-CCF02C	No
Power Exhaust (460V) Vertical	RXXR-CCF02D	No
Power Exhaust (230V) Horizontal	RXXR-CCF03C	No
Power Exhaust (460V) Horizontal	RXXR-CCF03D	No
Manual Fresh Air Damper	RXRF-ACA1	No
Motorized Fresh Air Damper	RXRF-ACB1	No
Roofcurb, 14"	RXKG-DCC14	No
Roofcurb, 24"	RXKG-DCC24	No
Roofcurb Adapter	RXXR-DCCAE	No
Roofcurb, 14" Welded	RXKG-DC14	No
Roofcurb, 24" Welded	RXKG-DC24	No
Concentric Diffuser 3-4 Ton Flush	RXRN-AEF1800	No
Concentric Diffuser 5-6 Ton Flush	RXRN-AEF2000	No
Concentric Diffuser 3-4 Ton Drop	RXRN-AED1800	No
Concentric Diffuser 5-6 Ton Drop	RXRN-AED2000	No
Concentric Adapter 3-4 Ton Drop	RXMC-DC01	No
Concentric Adapter 5-6 Ton Drop	RXMC-DC02	No
Outdoor Coil Louver Kit	RXXR-ADD04C	Yes
Nonpowered Convenience Outlet	RXXR-BN01	Yes
Unfused Service Disconnect	RXXR-BP01	Yes
Comfort Alert (1 Phase) DDC	RXXR-AZ03	Yes

Accessory	Model Number	Factory Installation Available?
Comfort Alert (1 Phase) Non-DDC	RXXR-AZ04	Yes
Comfort Alert (3 Phase) DDC	RXXR-AZ01	Yes
Comfort Alert (3 Phase) Non-DDC	RXXR-AZ02	Yes
Carbon Dioxide Sensor (Wall Mount)	RXXR-AR02	No
BACnet Communication Card	RXXR-AY01	No
LonWorks Communication Card	RXXR-AY02	No
Room Humidity Sensor	RHC-ZNS4	No
Room Temperature and Relative Humidity	RHC-ZNS5	No
Low-Ambient Control Kit	RXRZ-A04	Yes
Freeze Stat Kit	RXXR-AM05	Yes
Return Smoke Detector (Field kit)	RXXR-BS01	No
Return/ Supply Smoke Detector (Field kit)	RXXR-BS02	No
Electric Heater Kits	RXJJ-DC10JT	Yes
	RXJJ-DC15JT	Yes
	RXJJ-DC20JT	Yes
	RXJJ-DC10CP	Yes
	RXJJ-DC15CP	Yes
	RXJJ-DC20CP	Yes
	RXJJ-DC24CP	Yes
	RXJJ-DC10DNV	Yes
	RXJJ-DC15DNV	Yes
	RXJJ-DC20DNV	Yes
Single Point Wiring Kits	RXJX-AJ0601 (Single Phase)	No
	RXJX-AZ0601 (Three Phase)	No
MERV 8 Filter	RXMF-M08A21616	No
MERV 13 Filter	RXMF-M13A21616	No



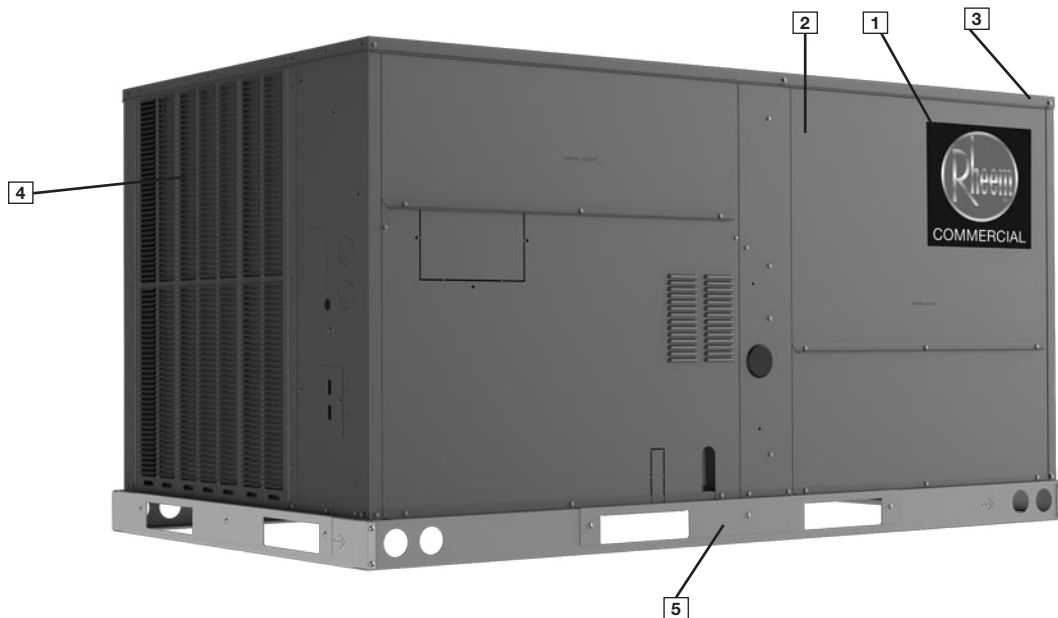

### Cabinet and Foundation

Outwardly, the large *Rheem® Commercial Series* label (1) identifies the brand to the customer. The sheet-metal cabinet (2) uses 18-gauge material for structural components with an under coat of G90. To ensure the leak-proof integrity of these units, the design utilizes a one-piece top with a 1/8" drip lip (3) as well as gasket-protected panels and screws. The Rheem hail guard (optional) (4) sets the standard for coil protection in the industry. Electro deposition, baked-on enamel that is tested to withstand a rigorous 1000-hour salt spray test, per ASTM B117.

Anything built to last must start with the right foundation. Following that model, the foundation is comprised of 14-gauge, commercial-grade, full perimeter base rails (5) that integrate fork slots and rigging holes to save set-up time on the job site.

### Easy Installation

The Renaissance line is designed to simplify the installation and replacement process with a new footprint that matches existing airflow inlets, outlets and electrical connections to commonly used curb configurations in the market today.

### Base Pan

The base pan is stamped to form a 7/8" flange around the supply and return cover, which eliminates the worry of water entering the conditioned space (6). All insulation is secured with both adhesive and mechanical fasteners, and all edges are hidden.



### Drain Pan

The Qwik-Clean Drain Pan™ (7) is made from a composite material that resists the growth of harmful bacteria. With both side and center drain options, the drain pan slides out completely for easy cleaning. It also features a standard overflow switch.



### Test Standards

During development, each unit was tested to U.L. 1995, AHRI 210/240 (3-5 ton) or AHRI 340/360 (6 ton), as well as other Rheem-required reliability tests. Rheem adheres to stringent ISO 9001 quality procedures, and each unit bears the U.L. and AHRI certification labels located on the unit nameplate. Contractors can be assured that when a Rheem package unit arrives at the job, it is ready to go with a factory charge and quality checks. Each unit also proudly displays the "Made in the USA" designation.

### Easy Access

All major compartments are easily accessible from the front of the unit: the electrical compartment, blower compartment, heating section, and outdoor section. Each compartment has mechanical fasteners. Panels are permanently embossed with the compartment name (e.g. control/filter access, blower access, and electric heat access). The filter compartment is accessed through a large, mechanically fastened panel. Information is readily available on the outside of the panel, with a nameplate that contains the model and serial numbers, electrical data, and other important unit information. Hinged access is available as an option for the electrical, blower, and filter compartments.

## Charging Charts, Wiring Diagrams, & Labels

The unit charging chart is located on the outside of the compressor access panel. Electrical wiring diagrams are found on the control box cover, which allows contractors to move them to more readable locations. The model and serial numbers are located on the right of the control box. Having this information on the inside means easier model identification for the life of the product. The production line quality test assurance label is also placed in this location **(8)**.

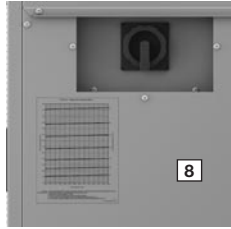

## Filter Rack

Located within the filter compartment, the Qwik-Change Flex-Fit Rack™ **(9)** allows easy changeover between 2" and 4" standard size and readily available filters.



## Blower Assembly

Removing three screws provides full access to the blower compartment. Inside, the Qwik-Slide Blower Assembly™ **(10)** is incredibly easy to access and remove. This makes servicing internal components such as blower motor, TXV, and microchannel coil much easier. The entire assembly slides out by removing the 3/8" screws from the blower retention bracket.

Where the demands for the job require high static, Rheem offers drives **(11)** that deliver nominal airflow up to 1.5" of static. By referring to the airflow performance tables listed in the installation instructions, proper static pressure and CFM requirements can be dialed in. The scroll housing **(12)** and blower scroll provide quiet and efficient airflow.

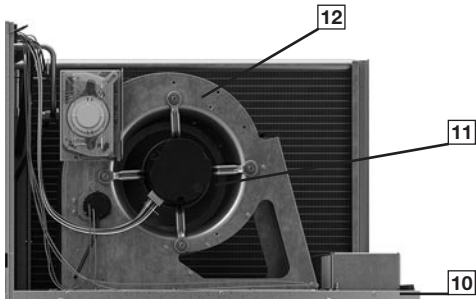

## High and Low Pressure Switches & Freeze Stat

High pressure **(13)** and low pressure **(14)** switches are standard. They are located in the outdoor section along with the low-ambient control **(15)**. The optional Freeze Stat **(16)** (standard on models with ClearControl), is clipped onto the suction line in the blower compartment. The low ambient control allows the compressor to operate down to 0 degrees ambient temperature by cycling the outdoor fans on high pressure. The high-pressure switch shuts off the compressors if pressures exceeding 610 PSIG are detected. The low-pressure switch shuts off the compressors if low pressure is detected due to loss of charge. Built-in Smart Logic reduces nuisance calls by only shutting off compressors after the third detection. The freeze stat protects the compressor if the evaporator coil gets too cold (below freezing) due to low airflow.

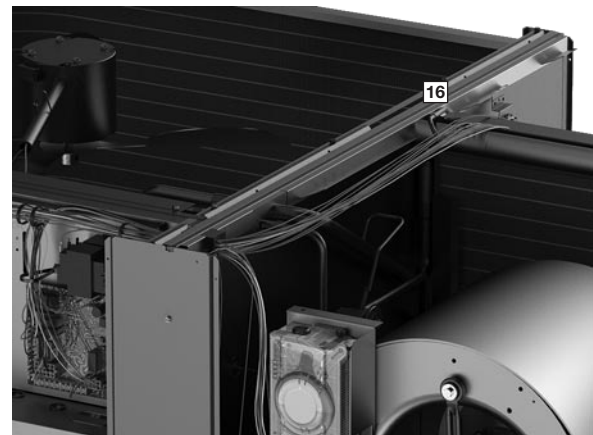
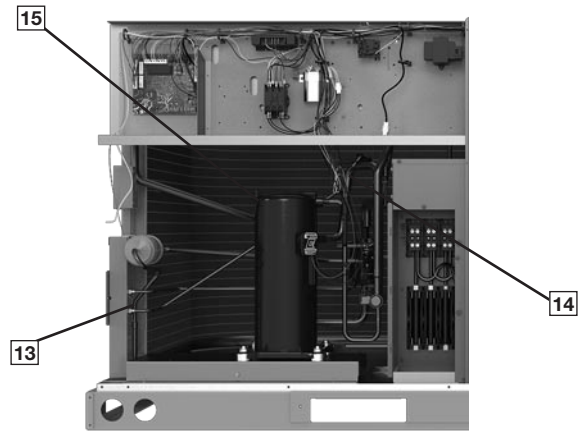

## MicroChannel Evaporator & TXV

The Microchannel Evaporator **(17)** is accessible through the blower compartment, and through the filter rack, to simplify cleaning. The evaporator uses microchannel technology for maximum heat transfer, light weight, fewer manually brazed connections and reduced refrigerant charge. The TXV metering device maintains superheat over a wide range of varying temperatures optimizing unit performance for all conditions.

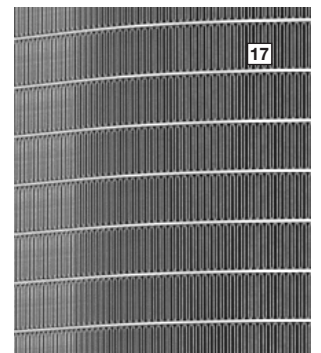

## Control Box

Inside the control box (18), each electrical component is clearly labeled; that label matches the component to the wire diagram for ease of trouble shooting. All wiring is numbered on each end of the termination and is color-coded to match the wiring diagram. The CoreCommand, incorporates the PlusOne Diagnostics: Dual 7-Segment LED Display (19) with easy-to-understand fault codes. The control transformer has a low voltage circuit breaker that trips if an electrical short occurs.



## ClearControl™ DDC System

The optional ClearControl™ Direct Digital Control (DDC) system consisting of a rooftop unit controller, temperature sensors, and pressure sensors, allows real-time monitoring and communication between rooftop units. The Rooftop Unit Controller (RTU-C) that is factory mounted and wired into the control panel. The RTU-C is a solid-state, microprocessor-based control board that provides flexible control and extensive diagnostics for all unit functions. The RTU-C, using proportional/integral control algorithms, performs specific unit functions that govern unit operation in response to zone conditions, system temperatures, system pressures, ambient conditions, and electrical inputs. The RTU-C features a 16 x 2 character LCD display and a five-button keypad for local configuration and direct diagnosis of the system (20). Features include a clogged filter switch (CFS), fan proving switch (FPS), return air temperature sensor (RAT), discharge air temperature sensor (DAT), and outdoor air temperature sensor (OAT). Freeze sensors (FS) are used in place of freeze stats to allow measurement of refrigerant suction line temperatures.

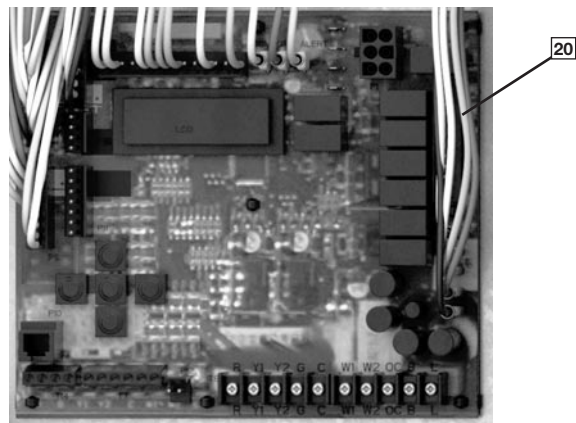

The RHPC Cooling only with the RTU-C is specifically designed to be applied in four distinct applications:

- 1. BACnet Communication** — The RHPC is compatible with a third party building management system that supports the BACnet Application Specific Controller device profile, with the use of a field installed BACnet Communication Module. The BACnet Communication Module plugs onto the unit RTU-C controller and allows communication between the RTU-C and the BACnet MSTP network. A zone sensor, a BACnet network zone sensor, a BACnet thermostat, or DDC controller may be used to send the zone temperature or thermostat demands to the RTU-C. The BACnet Communication Module is compatible with MSTP EIA-485 daisy chain networks communicating at 38.4 bps. It is compatible with twisted pair, shielded cables.
- 2. LonWorks Communication** — The RHPC is compatible with a third party building management system that supports the LonMark Space Comfort Controller (SCC) functional profile or LonMark Discharge Air Controller (DAC) functional profile. This is accomplished with a field installed LonMark communication module. The LonMark Communication Module plugs onto the RTU-C controller and allows communication between the RTU-C and a LonWorks network. A zone sensor, a LonTalk network zone sensor, or a LonTalk thermostat or DDC controller may be used to send the zone temperature or thermostat demands to the RTU-C. The LonMark Communication Module utilizes an FTT-10A free topology transceiver communicating at 78.8 kbps. It is compatible with Echelon qualified, twisted pair cable, Belden 8471, or NEMA Level 4 cables. The module can communicate up to 1640 feet with no repeater. The LonWorks limit of 64 nodes per segment applies to this device.
- 3. 24V Thermostat Compatibility** — The RHPC is compatible with a programmable 24 volt thermostat. Connections are made via conventional thermostat screw terminals. Extensive unit status and diagnostics are displayed on the LCD screen of the RTU-C.
- 4. Zone Sensor Compatibility** — The RHPC is compatible with a zone sensor and a mechanical or solid state time clock connected to the RTU-C. Extensive unit status and diagnostics are displayed on the LCD screen of the RTU-C.

## ComfortAlert®

A factory or field installed Comfort Alert® (21) module is available for power phase-monitoring protection and additional compressor diagnostics. The alarms can be displayed on the RTU-C display, through the (BAS) network, or connected to the “L-Terminal” of a thermostat for notification.

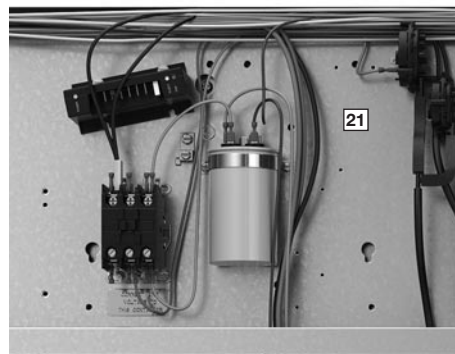

## Convenience Outlet, Disconnect, & Circuit Breaker

The convenience outlet option comes non-powered from the factory (23). Low and high voltage can enter from the side or through the base. Low-voltage connections are made through the low-voltage terminal strip. For ease of access, the U.L.-required low voltage barrier can be temporarily removed for low-voltage termination and then reinstalled. The high-voltage connection is terminated at the number 1 compressor contactor. The suggested mounting for the field-installed disconnect or circuit breaker is on the exterior side of the electrical control box.

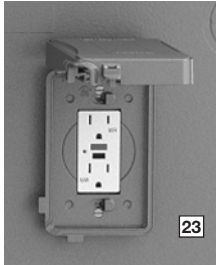

## External Lockable Gauge Ports

To the right left of the compressor compartment are the externally mounted lockable gauge ports. They are permanently identified by embossed lettering that identifies the compressor circuit, high pressure connection, (25) and low pressure connection (26). Because the gauge ports are mounted externally, an accurate diagnostic of system operation can be performed without removing access panels. Brass caps on the Schrader fitting ensure the gauge parts are leak proof.

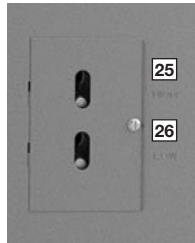

## Compressor

The compressor compartment houses the heartbeat of the unit. The scroll compressor (30) is known for its long life and for reliable, quiet, and efficient operation. The suction and discharge lines are designed with shock loops (31) to absorb the strain and stress that the starting torque, steady state operation, and shut-down cycle impose on the refrigerant tubing. 6-Ton model includes 2-Stage scroll compressor as standard, 3-5 ton models include one single-stage compressor.



## Condenser Fans

The condenser fan motor (32) can easily be accessed and maintained through the top of the unit. A down-mount fan provides corrosion protection and easy removal. The polarized plug connection allows the motor to be changed quickly and eliminates the need to snake wires through the unit.



## MicroChannel Condenser Technology

The outdoor coil uses the latest microchannel technology (33) for the most effective method of heat transfer. The outdoor coil is protected by optional louvered panels, which allow unobstructed airflow while protecting the unit from both the environment and vandalism.

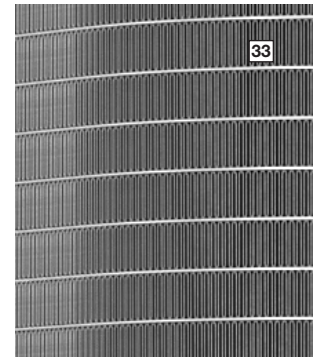

## Coil Coating

Every unit offers the option of factory-applied ElectroFin® E-Coat condenser coating (34) that delivers superior corrosion resistance for outdoor coils to operate in the harshest of environments.





## Economizer and Dampers

Each unit is designed for both down flow or horizontal applications (35) for job configuration flexibility. The return air compartment can also contain an economizer. Each unit is pre-wired for the economizer to allow quick, plug-in installation. Available as a factory-installed option, the economizer provides free cooling when outdoor conditions are suitable and also provides fresh air to meet local requirements.

It comes standard with single enthalpy controls, which can be upgraded to dual enthalpy

easily in the field. The direct drive actuator combined with gear drive dampers has eliminated the need for linkage adjustment in the field. The economizer control has a minimum position set point, an outdoor-air set point, a mixed-air set point, and a CO<sub>2</sub> set point. Barometric relief is standard on all economizers.



Power Exhaust is easily field-installed. The power exhaust is housed in the barometric relief opening and is easily slipped in with a plugin assembly. The wire harness to the economizer also has accommodations for a smoke detector.

The damper minimum position, actual damper position, power exhaust on/off set point, mixed air temperature limit set point, and Demand Controlled Ventilation (DCV) set point can be read and adjusted at the unit controller display or remotely through a network connection. The Space CO<sub>2</sub> level, mixed air temperature, and Economizer Status (free cooling available, single or dual enthalpy) can be read at the unit controller display or remotely through a network connection. Economizer faults will trigger a network alarm and can be read at the unit controller display or remotely through a network connection.

## Roofcurb

The Rheem roofcurb (36) is made for tool-less assembly at the jobsite by engaging tabs in slots of adjacent curb sides, which makes the assembly process quick and easy.





**R** **HP** **C** **ZR** **036** **A** **C** **T** **10** **2** **A** **A** **\*\*\***  
**1** **23** **4** **56** **789** **10** **11** **12** **13 14** **15** **16** **17** **18 19 20**

**1 – Brand**

R = Rheem

**2, 3 – Unit Type**

HP = Package HP

**4 – Cabinet Type**

C = Small Commercial

**5, 6 – Series**

ZR = Tier 3 (*Commercial Classic® Series*)

ZT = Tier 1 (*Commercial Prestige® Series*)

**7, 8, 9 – Capacity**

036 = 3 Ton

048 = 4 Ton

060 = 5 Ton

072 = 6 Ton

**10 – Major series**

A

**11 – Voltage**

J = 1 phase 208-230/60

C = 3 phase 208-230/60

D = 3 phase 460/60

**12 – Drive**

T = Direct Drive Standard Static Constant Torque

U = Direct Drive High Static Constant Torque

**13, 14 – Heat Capacity**

00 = No Heat

10 = 10 kw

15 = 15 kw

20 = 20 kw

24 = 24 kw

**15 – Heat Configuration**

1 = 1-stage

2 = 2-stage

**16 – Control**

A = Core Command (Non-Communicating)

B = Core Command with Phase Monitor

C = Clear Control (DDC)

D = Clear Control (DDC) & Comfort Alert

**17 – Minor series**

A = First Generation

B = Second Generation

C = 3-5T DOE 2023 Compliant

**18, 19, 20 – Option Code**

See next page



## FACTORY INSTALLED OPTION CODES FOR RHPC (3 TO 6 TON)

18					19					20			
LV = Louver protection					LF = Low Ambient / Freeze Stat					EC = Economizer			
RH = ReHeat										SS = Supply and Return Smoke Detector			
HA = Hinged Access					NP = Non-powered Convenience Outlet					RS = Return Smoke Detector			
CC <sup>2</sup> = Coil Coating													
Option code character highlighted below					Option code character highlighted below					Option code character highlighted below			
<b>A</b>	None				<b>A</b>	None				<b>0</b>	None		
<b>B</b>	LV				<b>B</b>	LF				<b>1</b>	EC		
<b>C</b>	HA				<b>C</b>	NP				<b>2</b>	RS		
<b>D</b>	LV	HA			<b>D</b>	LF	NP			<b>3</b>	EC	RS	
<b>E</b>	LV	CC								<b>4</b>	SS	RS	
<b>F</b>	LV	HA	CC							<b>5</b>	EC	SS	RS
<b>G</b>	RH												
<b>H</b>	LV	RH											
<b>J</b>	RH	HA											
<b>K</b>	LV	RH	CC										
<b>L</b>	LV	RH	HA										
<b>M</b>	LV	RH	HA	CC									

<sup>2</sup>CC-requires LV (louver protection)

### Instructions for Factory Installed Option(s) Selection

Note: Three characters following the model number will be utilized to designate a factory-installed option or combination of options. If no factory option(s) is required, "AAO" follows the model number.

- **Step 1:** In the table above, based on the desired features, choose option code character from highlighted options on the left side under the number 18. For example, the option code character "E" has Louver protection and Coil Coating.
- **Step 2:** In the table above, based on the desired features, choose option code character from highlighted options on the left side under the number 19. For example, the option code character "F" has Low Ambient / Freeze Stat and Disconnect switch.
- **Step 3:** In the table above, based on the desired features, choose option code character from highlighted options on the left side under the number 20. For example, the option code character "3" has Economizer and Return Smoke.
- The resulting option code from examples above is: "EF3"
- **Step 4:** Add your option code selection to the end of model number

◦ Example: RHPCZR036ACT000AA      EF3      = RHPCZR036ACT000AAEF3

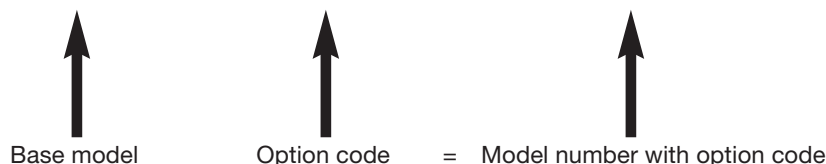

## NOM. SIZES 3-6 TONS [10.6-21.1 kW] ASHRAE 90.1 2019 COMPLIANT MODELS

Model RHPCZ(-) Series	036ACT	036ACU	036ADT	036ADU
<b>Cooling Performance<sup>A</sup></b>				<b>CONTINUED</b> →
Gross Cooling Capacity Btu [kW]	36,000 [10.55]	36,000 [10.55]	36,000 [10.55]	36,000 [10.55]
EER/EER2	11/10.6	11/10.6	11/10.6	11/10.6
SEER/SEER2 <sup>B</sup>	14/13.4	14/13.4	14/13.4	14/13.4
Nominal CFM [L/s]	1200 [566]	1200 [566]	1200 [566]	1200 [566]
AHRI Rated CFM (SEER/SEER2) [L/s]	1280/1080 [566/509]	1280/1080 [566/509]	1280/1080 [566/509]	1280/1080 [566/509]
AHRI Net Cooling Capacity Btu (SEER/SEER2) [kW]	35,400 [10.37]	35,400 [10.37]	35,400 [10.37]	35,400 [10.37]
Net Sensible Capacity Btu (SEER/SEER2) [kW]	26,300 [7.71]	26,300 [7.71]	26,300 [7.71]	26,300 [7.71]
Net Latent Capacity Btu (SEER/SEER2) [kW]	9,100 [2.67]	9,100 [2.67]	9,100 [2.67]	9,100 [2.67]
Net System Power kW (SEER/SEER2)	2.78/3.33	2.78/3.33	2.78/3.33	2.78/3.33
<b>Heating Performance (Heat Pumps)</b>				
High Temp. Btuh [kW] Rating	34,400 [10.08]	34,400 [10.08]	34,400 [10.08]	34,400 [10.08]
System Power KW / COP	2.82/3.7	2.82/3.7	2.82/3.7	2.82/3.7
Low Temp. Btuh [kW] Rating	20,000 [5.86]	20,000 [5.86]	20,000 [5.86]	20,000 [5.86]
System Power KW / COP	2.68/2.24	2.68/2.24	2.68/2.24	2.68/2.24
HSPF/HSPF2 (Btu/Watts-hr)	8/6.7	8/6.7	8/6.7	8/6.7
<b>Compressor</b>				
No./Type	1/Scroll	1/Scroll	1/Scroll	1/Scroll
No./Stages	1	1	1	1
<b>Outdoor Coil - Fin Type</b>	Louvered	Louvered	Louvered	Louvered
Tube Type	MicroChannel	MicroChannel	MicroChannel	MicroChannel
MicroChannel Depth in. [mm]	0.71 [18]	0.71 [18]	0.71 [18]	0.71 [18]
Face Area sq. ft. [sq. m]	16.48 [1.53]	16.48 [1.53]	16.48 [1.53]	16.48 [1.53]
Rows / FPI [FPcm]	1 / 23 [9]	1 / 23 [9]	1 / 23 [9]	1 / 23 [9]
Refrigerant Control	TX Valves	TX Valves	TX Valves	TX Valves
<b>Indoor Coil - Fin Type</b>	Louvered	Louvered	Louvered	Louvered
Tube Type	MicroChannel	MicroChannel	MicroChannel	MicroChannel
Tube Size in. [mm] OD	0.375 [9.5]	0.375 [9.5]	0.375 [9.5]	0.375 [9.5]
Face Area sq. ft. [sq. m]	7.52 [0.7]	7.52 [0.7]	7.52 [0.7]	7.52 [0.7]
Rows / FPI [FPcm]	1 / 20 [8]	1 / 20 [8]	1 / 20 [8]	1 / 20 [8]
Refrigerant Control	TX Valves	TX Valves	TX Valves	TX Valves
Drain Connection No./Size in. [mm]	1/0.75 [19.05]	1/0.75 [19.05]	1/0.75 [19.05]	1/0.75 [19.05]
<b>Outdoor Fan - Type</b>	Propeller	Propeller	Propeller	Propeller
No. Used/Diameter in. [mm]	1/26 [660.4]	1/26 [660.4]	1/26 [660.4]	1/26 [660.4]
Drive Type/No. Speeds	Direct/1	Direct/1	Direct/1	Direct/1
CFM [L/s]	4600 [2171]	4600 [2171]	4600 [2171]	4600 [2171]
No. Motors/HP	1 at 1/5 HP	1 at 1/5 HP	1 at 1/5 HP	1 at 1/5 HP
Motor RPM	820	820	820	820
<b>Indoor Fan - Type</b>	FC Centrifugal	FC Centrifugal	FC Centrifugal	FC Centrifugal
No. Used/Diameter in. [mm]	1/11x11 [279x279]	1/11x11 [279x279]	1/11x11 [279x279]	1/11x11 [279x279]
Drive Type	Direct	Direct	Direct	Direct
No. Speeds	Multiple	Multiple	Multiple	Multiple
No. Motors	1	1	1	1
Motor HP	3/4	1 1/2	3/4	1
Motor RPM	1050	1400	1050	1050
Motor Frame Size	48	48	48	48
<b>Filter - Type</b>	Disposable	Disposable	Disposable	Disposable
Furnished	Yes	Yes	Yes	Yes
(NO.) Size Recommended in. [mm x mm x mm]	(4)2x16x16 [51x406x406]	(4)2x16x16 [51x406x406]	(4)2x16x16 [51x406x406]	(4)2x16x16 [51x406x406]
<b>Refrigerant Charge Oz. [g]</b>	91 [2580]	91 [2580]	91 [2580]	91 [2580]
<b>Weights</b>				
Net Weight lbs. [kg]	557 [253]	557 [253]	557 [253]	557 [253]
Ship Weight lbs. [kg]	595 [270]	595 [270]	595 [270]	595 [270]

See Page 18 for Notes.

[ ] Designates Metric Conversions

## NOM. SIZES 3-6 TONS [10.6-21.1 kW] ASHRAE 90.1 2019 COMPLIANT MODELS

Model RHPCZ(-) Series	036AJT	036AJU
<b>Cooling Performance<sup>A</sup></b>		
Gross Cooling Capacity Btu [kW]	36,000 [10.55]	36,000 [10.55]
EER/EER2	11/10.6	11/10.6
SEER/SEER2 <sup>B</sup>	14/13.4	14/13.4
Nominal CFM [L/s]	3000 [1416]	3000 [1416]
AHRI Rated CFM (SEER/SEER2) [L/s]	1280/1280 [604/604]	1280/1280 [604/604]
AHRI Net Cooling Capacity Btu (SEER/SEER2) [kW]	35,400/35,400 [10.37/10.37]	35,400/35,400 [10.37/10.37]
Net Sensible Capacity Btu (SEER/SEER2) [kW]	26,300/26,300 [7.71/7.71]	26,300/26,300 [7.71/7.71]
Net Latent Capacity Btu (SEER/SEER2) [kW]	9,100/9,100 [2.67/2.67]	9,100/9,100 [2.67/2.67]
Net System Power kW (SEER/SEER2)	2.78/2.78	2.78/2.78
<b>Heating Performance (Heat Pumps)</b>		
High Temp. Btuh [kW] Rating	34,400 [10.08]	34,400 [10.08]
System Power KW / COP	2.82/3.7	2.82/3.7
Low Temp. Btuh [kW] Rating	20,000 [5.86]	20,000 [5.86]
System Power KW / COP	2.68/2.24	2.68/2.24
HSPF/HSPF2 (Btu/Watts-hr)	8/6.7	8/6.7
<b>Compressor</b>		
No./Type	1/Scroll	1/Scroll
No./Stages	1	1
<b>Outdoor Coil - Fin Type</b>		
Tube Type	Louvered	Louvered
MicroChannel Depth in. [mm]	MicroChannel	MicroChannel
Face Area sq. ft. [sq. m]	0.71 [18]	0.71 [18]
Rows / FPI [FPcm]	25.4 [2.36]	25.4 [2.36]
Refrigerant Control	1 / 23 [9]	1 / 23 [9]
<b>Indoor Coil - Fin Type</b>		
Tube Type	Louvered	Louvered
Tube Size in. [mm] OD	MicroChannel	MicroChannel
Face Area sq. ft. [sq. m]	1 [25.4]	1 [25.4]
Rows / FPI [FPcm]	11 [1.02]	11 [1.02]
Refrigerant Control	1 / 20 [8]	1 / 20 [8]
Drain Connection No./Size in. [mm]	TX Valves	TX Valves
<b>Outdoor Fan - Type</b>		
No. Used/Diameter in. [mm]	Propeller	Propeller
Drive Type/No. Speeds	2/24 [609.6]	2/24 [609.6]
CFM [L/s]	Direct/1	Direct/1
No. Motors/HP	8000 [3775]	8000 [3775]
Motor RPM	1 at 1/5 HP	1 at 1/5 HP
<b>Indoor Fan - Type</b>		
No. Used/Diameter in. [mm]	FC Centrifugal	FC Centrifugal
Drive Type	1/11x11 [279x279]	1/11x11 [279x279]
No. Speeds	Direct	Direct
No. Motors	Multiple	Multiple
Motor HP	1	1
Motor RPM	3/4	1 1/2
Motor Frame Size	1050	1400
<b>Filter - Type</b>		
Furnished	Disposable	Disposable
(NO.) Size Recommended in. [mm x mm x mm]	Yes	Yes
<b>Refrigerant Charge Oz. [g]</b>		
	91 [2580]	91 [2580]
<b>Weights</b>		
Net Weight lbs. [kg]	807 [366]	807 [366]
Ship Weight lbs. [kg]	846 [384]	846 [384]

**CONTINUED** →

See Page 18 for Notes.

[ ] Designates Metric Conversions

## NOM. SIZES 3-6 TONS [10.6-21.1 kW] ASHRAE 90.1 2019 COMPLIANT MODELS

Model RHPCZ(-) Series	048ACT	048ACU	048ADT	048ADU
<b>Cooling Performance<sup>A</sup></b>				<b>CONTINUED</b> →
Gross Cooling Capacity Btu [kW]	47,000 [13.77]	47,000 [13.77]	47,000 [13.77]	47,000 [13.77]
EER/EER2	11/10.6	11/10.6	11/10.6	11/10.6
SEER/SEER2 <sup>B</sup>	14/13.4	14/13.4	14/13.4	14/13.4
Nominal CFM [L/s]	1600 [755]	1600 [755]	1600 [755]	1600 [755]
AHRI Rated CFM (SEER/SEER2) [L/s]	1490/1490 [703/703]	1490/1490 [703/703]	1490/1490 [703/703]	1490/1490 [703/703]
AHRI Net Cooling Capacity Btu (SEER/SEER2) [kW]	46,000/46,000 [13.48/13.48]	46,000/46,000 [13.48/13.48]	46,000/46,000 [13.48/13.48]	46,000/46,000 [13.48/13.48]
Net Sensible Capacity Btu (SEER/SEER2) [kW]	34,680/34,680 [10.16/10.16]	34,680/34,680 [10.16/10.16]	34,680/34,680 [10.16/10.16]	34,680/34,680 [10.16/10.16]
Net Latent Capacity Btu (SEER/SEER2) [kW]	11,320/11,320 [3.32/3.32]	11,320/11,320 [3.32/3.32]	11,320/11,320 [3.32/3.32]	11,320/11,320 [3.32/3.32]
Net System Power kW (SEER/SEER2)	4.04/4.33	4.04/4.33	4.04/4.33	4.04/4.33
<b>Heating Performance (Heat Pumps)</b>				
High Temp. Btuh [kW] Rating	46,000 [13.48]	46,000 [13.48]	46,000 [13.48]	46,000 [13.48]
System Power KW / COP	3.82/3.5	3.82/3.5	3.82/3.5	3.82/3.5
Low Temp. Btuh [kW] Rating	20,000 [5.86]	20,000 [5.86]	20,000 [5.86]	20,000 [5.86]
System Power KW / COP	3.6/2	3.6/2	3.6/2	3.6/2
HSPF/HSPF2 (Btu/Watts-hr)	8/6.7	8/	8/	8/
<b>Compressor</b>				
No./Type	1/Scroll	1/Scroll	1/Scroll	1/Scroll
No./Stages	1	1	1	1
<b>Outdoor Coil - Fin Type</b>	Louvered	Louvered	Louvered	Louvered
Tube Type	MicroChannel	MicroChannel	MicroChannel	MicroChannel
MicroChannel Depth in. [mm]	0.71 [18]	0.71 [18]	0.71 [18]	0.71 [18]
Face Area sq. ft. [sq. m]	16.52 [1.53]	16.52 [1.53]	16.52 [1.53]	16.52 [1.53]
Rows / FPI [FPcm]	1 / 23 [9]	1 / 23 [9]	1 / 23 [9]	1 / 23 [9]
Refrigerant Control	TX Valves	TX Valves	TX Valves	TX Valves
<b>Indoor Coil - Fin Type</b>	Louvered	Louvered	Louvered	Louvered
Tube Type	MicroChannel	MicroChannel	MicroChannel	MicroChannel
Tube Size in. [mm] OD	0.375 [9.5]	0.375 [9.5]	0.375 [9.5]	0.375 [9.5]
Face Area sq. ft. [sq. m]	7.52 [0.7]	7.52 [0.7]	7.52 [0.7]	7.52 [0.7]
Rows / FPI [FPcm]	1 / 20 [8]	1 / 20 [8]	1 / 20 [8]	1 / 20 [8]
Refrigerant Control	TX Valves	TX Valves	TX Valves	TX Valves
Drain Connection No./Size in. [mm]	1/0.75 [19.05]	1/0.75 [19.05]	1/0.75 [19.05]	1/0.75 [19.05]
<b>Outdoor Fan - Type</b>	Propeller	Propeller	Propeller	Propeller
No. Used/Diameter in. [mm]	1/26 [660.4]	1/26 [660.4]	1/26 [660.4]	1/26 [660.4]
Drive Type/No. Speeds	Direct/1	Direct/1	Direct/1	Direct/1
CFM [L/s]	5900 [2784]	5900 [2784]	5900 [2784]	5900 [2784]
No. Motors/HP	1 at 1/2 HP	1 at 1/2 HP	1 at 1/2 HP	1 at 1/2 HP
Motor RPM	1075	1075	1075	1075
<b>Indoor Fan - Type</b>	FC Centrifugal	FC Centrifugal	FC Centrifugal	FC Centrifugal
No. Used/Diameter in. [mm]	1/11x11 [279x279]	1/11x11 [279x279]	1/11x11 [279x279]	1/11x11 [279x279]
Drive Type	Direct	Direct	Direct	Direct
No. Speeds	Multiple	Multiple	Multiple	Multiple
No. Motors	1	1	1	1
Motor HP	3/4	1 1/2	3/4	1
Motor RPM	1050	1400	1050	1050
Motor Frame Size	48	48	48	48
<b>Filter - Type</b>	Disposable	Disposable	Disposable	Disposable
Furnished	Yes	Yes	Yes	Yes
(NO.) Size Recommended in. [mm x mm x mm]	(4)2x16x16 [51x406x406]	(4)2x16x16 [51x406x406]	(4)2x16x16 [51x406x406]	(4)2x16x16 [51x406x406]
<b>Refrigerant Charge Oz. [g]</b>	142 [4026]	142 [4026]	142 [4026]	142 [4026]
<b>Weights</b>				
Net Weight lbs. [kg]	580 [263]	580 [263]	580 [263]	580 [263]
Ship Weight lbs. [kg]	618 [280]	618 [280]	618 [280]	618 [280]

See Page 18 for Notes.

[ ] Designates Metric Conversions

## NOM. SIZES 3-6 TONS [10.6-21.1 kW] ASHRAE 90.1 2019 COMPLIANT MODELS

Model RHPCZ(-) Series	048AJT	048AJU	060ACT	060ACU
<b>Cooling Performance<sup>A</sup></b>				<b>CONTINUED</b> →
Gross Cooling Capacity Btu [kW]	47,000 [13.77]	47,000 [13.77]	59,500 [17.43]	59,500 [17.43]
EER/EER2	11/10.6	11/10.6	11/10.6	11/10.6
SEER/SEER2 <sup>B</sup>	14/13.4	14/13.4	14/13.4	14/13.4
Nominal CFM [L/s]	1600 [755]	1600 [755]	2000 [944]	2000 [944]
AHRI Rated CFM (SEER/SEER2) [L/s]	1685/1685 [795/795]	1685/1685 [795/795]	2050/2050 [967/967]	2050/2050 [967/967]
AHRI Net Cooling Capacity Btu (SEER/SEER2) [kW]	46,000/46,000 [13.48/13.48]	46,000/46,000 [13.48/13.48]	57,500/57,500 [16.85/16.85]	57,500/57,500 [16.85/16.85]
Net Sensible Capacity Btu (SEER/SEER2) [kW]	34,680/34,680 [10.16/10.16]	34,680/34,680 [10.16/10.16]	43,020/43,020 [12.6/12.6]	43,020/43,020 [12.6/12.6]
Net Latent Capacity Btu (SEER/SEER2) [kW]	11,320/11,320 [3.32/3.32]	11,320/11,320 [3.32/3.32]	14,480/14,480 [4.24/4.24]	14,480/14,480 [4.24/4.24]
Net System Power kW (SEER/SEER2)	4.04/4.04	4.04/4.04	4.96/5.42	4.96/5.42
<b>Heating Performance (Heat Pumps)</b>				
High Temp. Btuh [kW] Rating	46,000 [13.48]	46,000 [13.48]	57,500 [16.85]	57,500 [16.85]
System Power KW / COP	3.82/3.5	3.82/3.5	5.09/3.5	5.09/3.5
Low Temp. Btuh [kW] Rating	20,000 [5.86]	20,000 [5.86]	35,000 [10.25]	35,000 [10.25]
System Power KW / COP	3.6/2	3.6/2	5.1/2	5.1/2
HSPF/HSPF2 (Btu/Watts-hr)	8/6.7	8/6.7	8/6.7	8/6.7
<b>Compressor</b>				
No./Type	1/Scroll	1/Scroll	1/Scroll	1/Scroll
No./Stages	1	1	1	1
<b>Outdoor Coil - Fin Type</b>	Louvered	Louvered	Louvered	Louvered
Tube Type	MicroChannel	MicroChannel	MicroChannel	MicroChannel
MicroChannel Depth in. [mm]	0.71 [18]	0.71 [18]	0.71 [18]	0.71 [18]
Face Area sq. ft. [sq. m]	16.48 [1.53]	16.48 [1.53]	16.52 [1.53]	16.52 [1.53]
Rows / FPI [FPcm]	1 / 23 [9]	1 / 23 [9]	1 / 23 [9]	1 / 23 [9]
Refrigerant Control	TX Valves	TX Valves	TX Valves	TX Valves
<b>Indoor Coil - Fin Type</b>	Louvered	Louvered	Louvered	Louvered
Tube Type	MicroChannel	MicroChannel	MicroChannel	MicroChannel
Tube Size in. [mm] OD	0.375 [9.5]	0.375 [9.5]	0.375 [9.5]	0.375 [9.5]
Face Area sq. ft. [sq. m]	7.52 [0.7]	7.52 [0.7]	7.52 [0.7]	7.52 [0.7]
Rows / FPI [FPcm]	1 / 20 [8]	1 / 20 [8]	1 / 20 [8]	1 / 20 [8]
Refrigerant Control	TX Valves	TX Valves	TX Valves	TX Valves
Drain Connection No./Size in. [mm]	1/0.75 [19.05]	1/0.75 [19.05]	1/0.75 [19.05]	1/0.75 [19.05]
<b>Outdoor Fan - Type</b>	Propeller	Propeller	Propeller	Propeller
No. Used/Diameter in. [mm]	1/26 [660.4]	1/26 [660.4]	1/26 [660.4]	1/26 [660.4]
Drive Type/No. Speeds	Direct/1	Direct/1	Direct/1	Direct/1
CFM [L/s]	5900 [2784]	5900 [2784]	5900 [2784]	5900 [2784]
No. Motors/HP	1 at 1/2 HP	1 at 1/2 HP	1 at 1/2 HP	1 at 1/2 HP
Motor RPM	1075	1075	1075	1075
<b>Indoor Fan - Type</b>	FC Centrifugal	FC Centrifugal	FC Centrifugal	FC Centrifugal
No. Used/Diameter in. [mm]	1/11x11 [279x279]	1/11x11 [279x279]	1/11x11 [279x279]	1/11x11 [279x279]
Drive Type	Direct	Direct	Direct	Direct
No. Speeds	Multiple	Multiple	Multiple	Multiple
No. Motors	1	1	1	1
Motor HP	3/4	1 1/2	1	1 1/2
Motor RPM	1050	1050	1050	1050
Motor Frame Size	48	48	48	48
<b>Filter - Type</b>	Disposable	Disposable	Disposable	Disposable
Furnished	Yes	Yes	Yes	Yes
(NO.) Size Recommended in. [mm x mm x mm]	(4)2x16x16 [51x406x406]	(4)2x16x16 [51x406x406]	(4)2x16x16 [51x406x406]	(4)2x16x16 [51x406x406]
<b>Refrigerant Charge Oz. [g]</b>	142 [4026]	142 [4026]	160 [4536]	160 [4536]
<b>Weights</b>				
Net Weight lbs. [kg]	580 [263]	580 [263]	583 [264]	583 [264]
Ship Weight lbs. [kg]	618 [280]	618 [280]	621 [282]	621 [282]

See Page 18 for Notes.

[ ] Designates Metric Conversions

## NOM. SIZES 3-6 TONS [10.6-21.1 kW] ASHRAE 90.1 2019 COMPLIANT MODELS

Model RHPCZ(-) Series	060ADT	060ADU	060AJT	060AJU
<b>Cooling Performance<sup>A</sup></b>				<b>CONTINUED</b> →
Gross Cooling Capacity Btu [kW]	59,500 [17.43]	59,500 [17.43]	59,500 [17.43]	59,500 [17.43]
EER/EER2	11/10.6	11/10.6	11/10.6	11/10.6
SEER/SEER2 <sup>B</sup>	14/13.4	14/13.4	14/13.4	14/13.4
Nominal CFM [L/s]	2000 [944]	2000 [944]	2000 [944]	2000 [944]
AHRI Rated CFM (SEER/SEER2) [L/s]	2050/2050 [967/967]	2050/2050 [967/967]	2050/2050 [967/967]	2050/2050 [967/967]
AHRI Net Cooling Capacity Btu (SEER/SEER2) [kW]	57,500/57,500 [16.85/16.85]	57,500/57,500 [16.85/16.85]	57,500/57,500 [16.85/16.85]	57,500/57,500 [16.85/16.85]
Net Sensible Capacity Btu (SEER/SEER2) [kW]	43,020/43,020 [12.6/12.6]	43,020/43,020 [12.6/12.6]	43,020/43,020 [12.6/12.6]	43,020/43,020 [12.6/12.6]
Net Latent Capacity Btu (SEER/SEER2) [kW]	14,480/14,480 [4.24/4.24]	14,480/14,480 [4.24/4.24]	14,480/14,480 [4.24/4.24]	14,480/14,480 [4.24/4.24]
Net System Power kW (SEER/SEER2)	4.96/4.96	4.96/4.96	4.96/4.96	4.96/4.96
<b>Heating Performance (Heat Pumps)</b>				
High Temp. Btuh [kW] Rating	57,500 [16.85]	57,500 [16.85]	57,500 [16.85]	57,500 [16.85]
System Power KW / COP	5.09/3.5	5.09/3.5	5.09/3.5	5.09/3.5
Low Temp. Btuh [kW] Rating	35,000 [10.25]	35,000 [10.25]	35,000 [10.25]	35,000 [10.25]
System Power KW / COP	5.1/2	5.1/2	5.1/2	5.1/2
HSPF/HSPF2 (Btu/Watts-hr)	8/6.7	8/6.7	8/6.7	8/6.7
<b>Compressor</b>				
No./Type	1/Scroll	1/Scroll	1/Scroll	1/Scroll
No./Stages	1	1	1	1
<b>Outdoor Coil - Fin Type</b>	Louvered	Louvered	Louvered	Louvered
Tube Type	MicroChannel	MicroChannel	MicroChannel	MicroChannel
MicroChannel Depth in. [mm]	0.71 [18]	0.71 [18]	0.71 [18]	0.71 [18]
Face Area sq. ft. [sq. m]	16.52 [1.53]	16.52 [1.53]	16.52 [1.53]	16.52 [1.53]
Rows / FPI [FPcm]	1 / 23 [9]	1 / 23 [9]	1 / 23 [9]	1 / 23 [9]
Refrigerant Control	TX Valves	TX Valves	TX Valves	TX Valves
<b>Indoor Coil - Fin Type</b>	Louvered	Louvered	Louvered	Louvered
Tube Type	MicroChannel	MicroChannel	MicroChannel	MicroChannel
Tube Size in. [mm] OD	0.375 [9.5]	0.375 [9.5]	0.375 [9.5]	0.375 [9.5]
Face Area sq. ft. [sq. m]	7.52 [0.7]	7.52 [0.7]	7.52 [0.7]	7.52 [0.7]
Rows / FPI [FPcm]	1 / 20 [8]	1 / 20 [8]	1 / 20 [8]	1 / 20 [8]
Refrigerant Control	TX Valves	TX Valves	TX Valves	TX Valves
Drain Connection No./Size in. [mm]	1/0.75 [19.05]	1/0.75 [19.05]	1/0.75 [19.05]	1/0.75 [19.05]
<b>Outdoor Fan - Type</b>	Propeller	Propeller	Propeller	Propeller
No. Used/Diameter in. [mm]	1/26 [660.4]	1/26 [660.4]	1/26 [660.4]	1/26 [660.4]
Drive Type/No. Speeds	Direct/1	Direct/1	Direct/1	Direct/1
CFM [L/s]	5900 [2784]	5900 [2784]	5900 [2784]	5900 [2784]
No. Motors/HP	1 at 1/2 HP	1 at 1/2 HP	1 at 1/2 HP	1 at 1/2 HP
Motor RPM	1075	1075	1075	1075
<b>Indoor Fan - Type</b>	FC Centrifugal	FC Centrifugal	FC Centrifugal	FC Centrifugal
No. Used/Diameter in. [mm]	1/11x11 [279x279]	1/11x11 [279x279]	1/11x11 [279x279]	1/11x11 [279x279]
Drive Type	Direct	Direct	Direct	Direct
No. Speeds	Multiple	Multiple	Multiple	Multiple
No. Motors	1	1	1	1
Motor HP	1	1 1/5	1	1 1/2
Motor RPM	1050	1300	1050	1400
Motor Frame Size	48	48	48	48
<b>Filter - Type</b>	Disposable	Disposable	Disposable	Disposable
Furnished	Yes	Yes	Yes	Yes
(NO.) Size Recommended in. [mm x mm x mm]	(4)2x16x16 [51x406x406]	(4)2x16x16 [51x406x406]	(4)2x16x16 [51x406x406]	(4)2x16x16 [51x406x406]
<b>Refrigerant Charge Oz. [g]</b>	160 [4536]	160 [4536]	160 [4536]	160 [4536]
<b>Weights</b>				
Net Weight lbs. [kg]	583 [264]	583 [264]	583 [264]	583 [264]
Ship Weight lbs. [kg]	621 [282]	621 [282]	621 [282]	621 [282]

See Page 18 for Notes.

[ ] Designates Metric Conversions



## NOM. SIZES 3-6 TONS [10.6-21.1 kW] ASHRAE 90.1 2019 COMPLIANT MODELS

Model RHP CZ(-) Series	072ACT	072ACU	072ADT	072ADU
<b>Cooling Performance<sup>A</sup></b>				
Gross Cooling Capacity Btu [kW]	70,000 [20.51]	70,000 [20.51]	70,000 [20.51]	70,000 [20.51]
EER/EER2	11/10.6	11/10.6	11/10.6	11/10.6
SEER/SEER2 <sup>B</sup>	14.1	14.1	14.1	14.1
Nominal CFM [L/s]	2400 [1133]	2400 [1133]	2400 [1133]	2400 [1133]
AHRI Rated CFM (SEER/SEER2) [L/s]	2400/2400 [1133/1133]	2400/2400 [1133/1133]	2400/2400 [1133/1133]	2400/2400 [1133/1133]
AHRI Net Cooling Capacity Btu (SEER/SEER2) [kW]	68000/68000 [19.92/19.92]	68000/68000 [19.92/19.92]	68000/68000 [19.92/19.92]	68000/68000 [19.92/19.92]
Net Sensible Capacity Btu (SEER/SEER2) [kW]	50199.9/50199.9 [14.71/14.71]	50199.9/50199.9 [14.71/14.71]	50199.9/50199.9 [14.71/14.71]	50199.9/50199.9 [14.71/14.71]
Net Latent Capacity Btu (SEER/SEER2) [kW]	17800.1/17800.1 [5.22/5.22]	17800.1/17800.1 [5.22/5.22]	17800.1/17800.1 [5.22/5.22]	17800.1/17800.1 [5.22/5.22]
Net System Power kW (SEER/SEER2)	6.18/6.18	6.18/6.18	6.18/6.18	6.18/6.18
<b>Heating Performance (Heat Pumps)</b>				
High Temp. Btuh [kW] Rating	68000 [19.92]	68000 [19.92]	68000 [19.92]	68000 [19.92]
System Power KW / COP	5.85/3.4	5.85/3.4	5.85/3.4	5.85/3.4
Low Temp. Btuh [kW] Rating	41000 [12.01]	41000 [12.01]	41000 [12.01]	41000 [12.01]
System Power KW / COP	5.34/2.25	5.34/2.25	5.34/2.25	5.34/2.25
<b>Compressor</b>				
No./Type	1/Scroll	1/Scroll	1/Scroll	1/Scroll
No./Stages	2	2	2	2
<b>Outdoor Sound Rating (dB)<sup>D</sup></b>				
	88	88	88	88
<b>Outdoor Coil - Fin Type</b>				
Tube Type	Louvered	Louvered	Louvered	Louvered
MicroChannel Depth in. [mm]	MicroChannel	MicroChannel	MicroChannel	MicroChannel
Face Area sq. ft. [sq. m]	1.26 [32]	1.26 [32]	1.26 [32]	1.26 [32]
Rows / FPI [FPcm]	16.52 [1.53]	16.52 [1.53]	16.52 [1.53]	16.52 [1.53]
Refrigerant Control	1 / 16 [9]	1 / 16 [9]	1 / 16 [9]	1 / 16 [9]
	TX Valves	TX Valves	TX Valves	TX Valves
<b>Indoor Coil - Fin Type</b>				
Tube Type	Louvered	Louvered	Louvered	Louvered
Tube Size in. [mm] OD	MicroChannel	MicroChannel	MicroChannel	MicroChannel
Face Area sq. ft. [sq. m]	1.26 [32]	1.26 [32]	1.26 [32]	1.26 [32]
Rows / FPI [FPcm]	7.52 [0.7]	7.52 [0.7]	7.52 [0.7]	7.52 [0.7]
Refrigerant Control	1 / 20 [8]	1 / 20 [8]	1 / 20 [8]	1 / 20 [8]
	TX Valves	TX Valves	TX Valves	TX Valves
Drain Connection No./Size in. [mm]	1/0.75 [19.05]	1/0.75 [19.05]	1/0.75 [19.05]	1/0.75 [19.05]
<b>Outdoor Fan - Type</b>				
Propeller	Propeller	Propeller	Propeller	Propeller
No. Used/Diameter in. [mm]	1/26 [660.4]	1/26 [660.4]	1/26 [660.4]	1/26 [660.4]
Drive Type/No. Speeds	Direct/1	Direct/1	Direct/1	Direct/1
CFM [L/s]	5900 [2784]	5900 [2784]	5900 [2784]	5900 [2784]
No. Motors/HP	1 at 1 HP	1 at 1 HP	1 at 1 HP	1 at 1 HP
Motor RPM	1075	1075	1075	1075
<b>Indoor Fan - Type</b>				
FC Centrifugal	FC Centrifugal	FC Centrifugal	FC Centrifugal	FC Centrifugal
No. Used/Diameter in. [mm]	1/11x11 [279x279]	1/11x11 [279x279]	1/11x11 [279x279]	1/11x11 [279x279]
Drive Type	Direct	Direct	Direct	Direct
No. Speeds	Multiple	Multiple	Multiple	Multiple
No. Motors	1	1	1	1
Motor HP	1 1/5	1 1/5	1 1/5	1 1/5
Motor RPM	1300	1300	1300	1300
Motor Frame Size	48	48	48	48
<b>Filter - Type</b>				
Disposable	Disposable	Disposable	Disposable	Disposable
Furnished	Yes	Yes	Yes	Yes
(NO.) Size Recommended in. [mm x mm x mm]	(4)2x16x16 [51x406x406]	(4)2x16x16 [51x406x406]	(4)2x16x16 [51x406x406]	(4)2x16x16 [51x406x406]
<b>Refrigerant Charge Oz. [g]</b>				
	160 [4536]	160 [4536]	160 [4536]	160 [4536]
<b>Weights</b>				
Net Weight lbs. [kg]	583 [264]	583 [264]	583 [264]	583 [264]
Ship Weight lbs. [kg]	621 [282]	621 [282]	621 [282]	621 [282]

See Page 18 for Notes.

[ ] Designates Metric Conversions



## NOTES:

- A. Cooling Performance is rated at 95° F ambient, 80° F entering dry bulb, 67° F entering wet bulb. Gross capacity does not include the effect of fan motor heat. AHRI capacity is net and includes the effect of fan motor heat. Units are suitable for operation to 20% of nominal cfm. Units are certified in accordance with the Unitary Air Conditioner Equipment certification program, which is based on AHRI Standard 210/240.
- B. EER and/or SEER are rated at AHRI conditions and in accordance with DOE test procedures.
- C. Integrated Energy Efficiency Ratio (IEER) is rated in accordance with AHRI Standard 340/360.
- D. Outdoor Sound Rating shown is tested in accordance with AHRI Standard 270.



## WEIGHTED SOUND POWER LEVEL (dBA)

Unit Size – Series	Standard Rating (dBA)	TYPICAL OCTAVE BAND SPECTRUM (dBA without tone adjustment)							
		63	125	250	500	1000	2000	4000	8000
RHPCZR036	78.6	46.2	64.4	63.8	68.4	69.1	66.2	61.4	56.7
RHPCZR048	83.8	54.2	62.7	75.7	72.6	72.9	70.4	66.5	61
RHPCZR060	83.3	55	61.7	71.6	72.4	73.1	70.5	66.4	62.5
RHPCZT072	83.3	55	61.7	71.6	72.4	73.1	70.5	66.4	62.5

Outdoor Sound Rating shown is tested in accordance with AHRI Standard 270.

# COOLING PERFORMANCE DATA — RHPCZR036A

wB/E		ENTERING INDOOR AIR @ 80°F [26.7°C] dB/E ①														
		71°F [21.7°C]			67°F [19.4°C]			63°F [17.2°C]			61°F [16.1°C]			59°F [15.0°C]		
CFM [L/s]		1350 [637]	1280 [604]	1050 [496]	1350 [637]	1280 [604]	1050 [496]	1350 [637]	1280 [604]	1050 [496]	1350 [637]	1280 [604]	1050 [496]	1350 [637]	1280 [604]	1050 [496]
75°F [23.9°C]	Total BTUH [kW]	44.1 [12.9]	43.7 [12.8]	42.3 [12.4]	41.4 [12.1]	41.0 [12.0]	39.7 [11.6]	39.4 [11.5]	37.7 [11.1]	37.1 [10.9]	38.3 [11.2]	38.3 [11.2]	37.1 [10.9]	38.3 [11.2]	37.9 [11.1]	36.7 [10.7]
	Sens BTUH [kW]	24.9 [7.3]	24.3 [7.1]	22.2 [6.5]	30.1 [8.8]	29.4 [8.6]	26.9 [7.9]	34.1 [10.0]	33.3 [9.8]	30.5 [8.9]	35.5 [10.4]	34.6 [10.1]	31.7 [9.3]	36.2 [10.6]	35.3 [10.3]	32.4 [9.5]
	Power	2.1	2.1	2.0	2.1	2.1	2.0	2.1	2.1	2.0	2.1	2.1	2.0	2.1	2.1	2.0
80°F [26.7°C]	Total BTUH [kW]	43.0 [12.6]	42.5 [12.5]	41.1 [12.1]	40.3 [11.8]	39.9 [11.7]	38.6 [11.3]	38.2 [11.2]	36.6 [10.7]	36.3 [10.6]	37.5 [11.0]	37.1 [10.9]	35.9 [10.5]	37.1 [10.9]	36.8 [10.8]	35.6 [10.4]
	Sens BTUH [kW]	24.4 [7.1]	23.8 [7.0]	21.8 [6.4]	29.6 [8.7]	28.9 [8.5]	26.5 [7.8]	33.6 [9.9]	32.8 [9.6]	30.0 [8.8]	34.9 [10.2]	34.1 [10.0]	31.2 [9.1]	35.7 [10.5]	34.8 [10.2]	31.9 [9.3]
	Power	2.2	2.2	2.2	2.2	2.2	2.1	2.2	2.2	2.1	2.2	2.2	2.1	2.2	2.2	2.1
85°F [29.4°C]	Total BTUH [kW]	41.7 [12.2]	41.3 [12.1]	40.0 [11.7]	39.0 [11.4]	38.6 [11.3]	37.4 [11.0]	37.0 [10.8]	35.4 [10.4]	35.3 [10.3]	36.3 [10.6]	35.9 [10.5]	34.8 [10.2]	35.9 [10.5]	35.5 [10.4]	34.4 [10.1]
	Sens BTUH [kW]	23.8 [7.0]	23.2 [6.8]	21.2 [6.2]	29.0 [8.5]	28.3 [8.3]	25.9 [7.6]	33.0 [9.7]	32.2 [9.4]	29.5 [8.6]	34.4 [10.1]	33.5 [9.8]	30.7 [9.0]	35.1 [10.3]	34.2 [10.0]	31.4 [9.2]
	Power	2.3	2.3	2.3	2.3	2.3	2.3	2.3	2.3	2.3	2.3	2.3	2.3	2.3	2.3	2.3
90°F [32.2°C]	Total BTUH [kW]	40.4 [11.8]	40.0 [11.7]	38.7 [11.3]	37.7 [11.1]	37.4 [10.9]	36.1 [10.6]	35.7 [10.5]	34.2 [10.0]	34.2 [10.0]	35.0 [10.3]	34.6 [10.2]	33.5 [9.8]	34.6 [10.1]	34.3 [10.0]	33.1 [9.7]
	Sens BTUH [kW]	23.1 [6.8]	22.5 [6.6]	20.6 [6.0]	28.3 [8.3]	27.6 [8.1]	25.3 [7.4]	32.3 [9.5]	31.5 [9.2]	28.9 [8.5]	33.7 [9.9]	32.8 [9.6]	30.1 [8.8]	34.4 [10.1]	33.6 [9.8]	30.8 [9.0]
	Power	2.5	2.5	2.4	2.5	2.4	2.4	2.5	2.4	2.4	2.4	2.4	2.4	2.4	2.4	2.4
95°F [35°C]	Total BTUH [kW]	39.1 [11.4]	38.7 [11.3]	37.4 [11.0]	36.4 [10.7]	36.0 [10.6]	34.8 [10.2]	34.3 [10.1]	32.9 [9.6]	32.9 [9.6]	33.6 [9.9]	33.3 [9.8]	32.2 [9.4]	33.2 [9.7]	32.9 [9.6]	31.8 [9.3]
	Sens BTUH [kW]	22.4 [6.6]	21.8 [6.4]	20.0 [5.9]	27.6 [8.1]	26.9 [7.9]	24.7 [7.2]	31.6 [9.3]	30.8 [9.0]	28.2 [8.3]	32.9 [9.7]	32.1 [9.4]	29.4 [8.6]	33.2 [9.7]	32.8 [9.6]	30.1 [8.8]
	Power	2.6	2.6	2.6	2.6	2.6	2.6	2.6	2.6	2.6	2.6	2.6	2.5	2.6	2.6	2.5
100°F [37.8°C]	Total BTUH [kW]	37.7 [11.0]	37.3 [10.9]	36.1 [10.6]	35.0 [10.2]	34.6 [10.1]	33.5 [9.8]	32.9 [9.6]	31.5 [9.2]	31.5 [9.2]	32.2 [9.4]	31.9 [9.3]	30.9 [9.0]	31.8 [9.3]	31.5 [9.2]	30.5 [8.9]
	Sens BTUH [kW]	21.5 [6.3]	21.0 [6.2]	19.2 [5.6]	26.8 [7.9]	26.1 [7.7]	23.9 [7.0]	30.8 [9.0]	30.0 [8.8]	27.5 [8.1]	32.1 [9.4]	31.3 [9.2]	28.7 [8.4]	31.8 [9.3]	31.5 [9.2]	29.4 [8.6]
	Power	2.8	2.8	2.7	2.8	2.8	2.7	2.8	2.8	2.7	2.8	2.8	2.7	2.8	2.8	2.7
105°F [40.6°C]	Total BTUH [kW]	36.2 [10.6]	35.8 [10.5]	34.6 [10.2]	33.5 [9.8]	33.1 [9.7]	32.1 [9.4]	31.4 [9.2]	30.1 [8.8]	29.9 [8.8]	30.7 [9.0]	30.4 [8.9]	29.4 [8.6]	30.3 [8.9]	30.0 [8.8]	29.1 [8.5]
	Sens BTUH [kW]	20.7 [6.1]	20.1 [5.9]	18.5 [5.4]	25.9 [7.6]	25.3 [7.4]	23.1 [6.8]	29.9 [8.8]	29.2 [8.5]	26.7 [7.8]	30.7 [9.0]	30.4 [8.9]	27.9 [8.2]	30.3 [8.9]	30.0 [8.8]	28.6 [8.4]
	Power	3.0	3.0	2.9	3.0	3.0	2.9	3.0	3.0	2.9	3.0	2.9	2.9	3.0	2.9	2.9
110°F [43.3°C]	Total BTUH [kW]	34.6 [10.1]	34.3 [10.0]	33.2 [9.7]	31.9 [9.4]	31.6 [9.3]	30.6 [9.0]	29.9 [8.8]	29.6 [8.7]	28.6 [8.4]	29.2 [8.6]	28.9 [8.5]	28.0 [8.2]	28.8 [8.4]	28.5 [8.4]	27.6 [8.1]
	Sens BTUH [kW]	19.7 [5.8]	19.2 [5.6]	17.6 [5.2]	25.0 [7.3]	24.3 [7.1]	22.3 [6.5]	29.0 [8.5]	28.2 [8.3]	25.9 [7.6]	29.2 [8.6]	28.9 [8.5]	27.1 [7.9]	28.8 [8.4]	28.5 [8.4]	27.6 [8.1]
	Power	3.2	3.2	3.1	3.2	3.2	3.1	3.2	3.2	3.1	3.2	3.1	3.1	3.2	3.1	3.1
115°F [46.1°C]	Total BTUH [kW]	33.0 [9.7]	32.7 [9.6]	31.6 [9.3]	30.3 [8.9]	30.0 [8.8]	29.1 [8.5]	28.3 [8.3]	28.0 [8.2]	27.1 [7.9]	27.6 [8.1]	27.3 [8.0]	26.4 [7.7]	27.2 [8.0]	26.9 [7.9]	26.0 [7.6]
	Sens BTUH [kW]	18.7 [5.5]	18.2 [5.3]	16.7 [4.9]	23.9 [7.0]	23.3 [6.8]	21.4 [6.3]	27.9 [8.2]	27.2 [8.0]	25.0 [7.3]	27.6 [8.1]	27.3 [8.0]	26.1 [7.7]	27.2 [8.0]	26.9 [7.9]	26.0 [7.6]
	Power	3.4	3.4	3.3	3.4	3.4	3.3	3.4	3.4	3.3	3.4	3.4	3.3	3.4	3.4	3.3
120°F [48.9°C]	Total BTUH [kW]	31.4 [9.2]	31.0 [9.1]	30.0 [8.8]	28.7 [8.4]	28.4 [8.3]	27.5 [8.0]	26.6 [7.8]	26.3 [7.7]	25.5 [7.5]	25.9 [7.6]	25.7 [7.5]	24.8 [7.3]	25.5 [7.5]	25.3 [7.4]	24.4 [7.2]
	Sens BTUH [kW]	17.6 [5.2]	17.1 [5.0]	15.7 [4.6]	22.8 [6.7]	22.3 [6.5]	20.4 [6.0]	26.6 [7.8]	26.2 [7.7]	24.0 [7.0]	25.9 [7.6]	25.7 [7.5]	24.8 [7.3]	25.5 [7.5]	25.3 [7.4]	24.4 [7.2]
	Power	3.6	3.6	3.6	3.6	3.6	3.6	3.6	3.6	3.5	3.6	3.6	3.5	3.6	3.6	3.5
125°F [51.7°C]	Total BTUH [kW]	29.6 [8.7]	29.3 [8.6]	28.4 [8.3]	26.9 [7.9]	26.7 [7.8]	25.8 [7.6]	24.9 [7.3]	24.6 [7.2]	23.8 [7.0]	24.2 [7.1]	23.9 [7.0]	23.2 [6.8]	23.8 [7.0]	23.6 [6.9]	22.8 [6.7]
	Sens BTUH [kW]	16.4 [4.8]	16.0 [4.7]	14.7 [4.3]	21.7 [6.4]	21.1 [6.2]	19.4 [5.7]	24.9 [7.3]	24.6 [7.2]	22.9 [6.7]	24.2 [7.1]	23.9 [7.0]	23.2 [6.8]	23.8 [7.0]	23.6 [6.9]	22.8 [6.7]
	Power	3.9	3.9	3.8	3.9	3.9	3.8	3.9	3.9	3.8	3.9	3.8	3.8	3.9	3.8	3.8

DR — Depression ratio  
 dB/E — Entering air dry bulb  
 wB/E — Entering air wet bulb

Total capacity x 1000 BTUH
— Total capacity x 1000 BTUH  
Sens
— Sensible capacity x 1000 BTUH  
Power
— KW input

NOTES: ① When the entering air dry bulb is other than 80°F [27°C], adjust the sensible capacity from the table by adding [1.10 x CFM x (1 - DR) x (dB/E - 80)].

[ ] Designates Metric Conversions

# HEATING PERFORMANCE DATA — RHPCZR036A

IDB	60°F [15.5°C]			70°F [21.1°C]			80°F [26.7°C]			
	CFM [L/s]	1350 [637]	1280 [604]	1050 [496]	1350 [637]	1280 [604]	1050 [496]	1350 [637]	1280 [604]	1050 [496]
OUTDOOR	Total BTUH [kW]	11.3 [3.3]	11.2 [3.3]	11.1 [3.3]	9.9 [2.9]	9.8 [2.9]	9.8 [2.9]	8.6 [2.5]	8.5 [2.5]	8.4 [2.5]
	Power	1.6	1.6	1.7	2.1	2.2	2.2	2.5	2.5	2.6
DRY	Total BTUH [kW]	13.8 [4.1]	13.8 [4.0]	13.6 [4.0]	12.5 [3.7]	12.4 [3.6]	12.3 [3.6]	11.1 [3.3]	11.1 [3.2]	10.9 [3.2]
	Power	1.7	1.7	1.7	2.2	2.2	2.3	2.5	2.5	2.6
BULB	Total BTUH [kW]	16.4 [4.8]	16.3 [4.8]	16.1 [4.7]	15.0 [4.4]	15.0 [4.4]	14.8 [4.3]	13.7 [4.0]	13.6 [4.0]	13.4 [3.9]
	Power	1.7	1.7	1.8	2.2	2.3	2.3	2.6	2.6	2.7
TEMPERATURE	Total BTUH [kW]	18.9 [5.5]	18.9 [5.5]	18.6 [5.5]	17.6 [5.2]	17.5 [5.1]	17.3 [5.1]	16.2 [4.8]	16.2 [4.7]	16.0 [4.7]
	Power	1.8	1.8	1.8	2.3	2.3	2.4	2.6	2.7	2.7
35°F [1.7°C]	Total BTUH [kW]	21.5 [6.3]	21.4 [6.3]	21.1 [6.2]	20.1 [5.9]	20.1 [5.9]	19.8 [5.8]	18.8 [5.5]	18.7 [5.5]	18.5 [5.4]
	Power	1.8	1.9	1.9	2.3	2.4	2.4	2.7	2.7	2.8
40°F [4.4°C]	Total BTUH [kW]	24.0 [7.0]	23.9 [7.0]	23.6 [6.9]	22.7 [6.6]	22.6 [6.6]	22.3 [6.5]	21.3 [6.3]	21.2 [6.2]	21.0 [6.1]
	Power	1.9	1.9	1.9	2.4	2.4	2.5	2.7	2.8	2.8
45°F [7.2°C]	Total BTUH [kW]	26.6 [7.8]	26.5 [7.8]	26.1 [7.7]	25.2 [7.4]	25.1 [7.4]	24.8 [7.3]	23.9 [7.0]	23.8 [7.0]	23.5 [6.9]
	Power	1.9	2.0	2.0	2.4	2.5	2.5	2.8	2.8	2.9
50°F [10.0°C]	Total BTUH [kW]	29.1 [8.5]	29.0 [8.5]	28.7 [8.4]	27.8 [8.1]	27.7 [8.1]	27.3 [8.0]	26.4 [7.7]	26.3 [7.7]	26.0 [7.6]
	Power	2.0	2.0	2.1	2.5	2.5	2.6	2.8	2.9	2.9
°F [°C]	Total BTUH [kW]	31.7 [9.3]	31.6 [9.3]	31.2 [9.1]	30.3 [8.9]	30.2 [8.9]	29.8 [8.7]	29.0 [8.5]	28.9 [8.5]	28.5 [8.4]
	Power	2.0	2.1	2.1	2.6	2.6	2.6	2.9	2.9	3.0
Indoor air dry bulb	Total BTUH [kW]	34.2 [10.0]	34.1 [10.0]	33.7 [9.9]	32.9 [9.6]	32.8 [9.6]	32.3 [9.5]	31.5 [9.2]	31.4 [9.2]	31.0 [9.1]
	Power	2.1	2.1	2.2	2.6	2.6	2.7	2.9	3.0	3.0
°F [°C]	Total BTUH [kW]	36.8 [10.8]	36.7 [10.7]	36.2 [10.6]	35.4 [10.4]	35.3 [10.3]	34.9 [10.2]	34.1 [10.0]	34.0 [9.9]	33.5 [9.8]
	Power	2.2	2.2	2.2	2.7	2.7	2.7	3.0	3.0	3.1

IDB—Indoor air dry bulb

[ ] Designates Metric Conversions

# COOLING PERFORMANCE DATA — RHPCZR048A

wB/E		ENTERING INDOOR AIR @ 80°F [26.7°C] dbE ①											
		71°F [21.7°C]		67°F [19.4°C]		63°F [17.2°C]		61°F [16.1°C]		59°F [15.0°C]			
CFM [L/s]	DR ①	1800 [850]	1685 [795]	1400 [661]	1800 [850]	1685 [795]	1400 [661]	1800 [850]	1685 [795]	1400 [661]	1800 [850]	1685 [795]	1400 [661]
75°F [23.9°C]	Total BTUH [kW]	58.5 [17.1]	57.7 [16.9]	56.0 [16.4]	54.3 [15.9]	53.7 [15.7]	52.0 [15.2]	50.7 [14.8]	50.0 [14.7]	48.5 [14.2]	49.0 [14.4]	48.4 [14.2]	46.9 [13.7]
	Sens BTUH [kW]	34.3 [10.0]	33.2 [9.7]	30.6 [9.0]	40.1 [11.7]	38.8 [11.4]	35.8 [10.5]	44.3 [13.0]	42.9 [12.6]	39.5 [11.6]	45.5 [13.3]	44.4 [13.0]	40.9 [12.0]
	Power	3.0	3.0	2.9	3.0	3.0	2.9	3.0	2.9	2.9	3.0	2.9	2.9
80°F [26.7°C]	Total BTUH [kW]	56.9 [16.7]	56.2 [16.5]	54.4 [16.0]	52.7 [15.4]	52.1 [15.3]	50.5 [14.8]	49.1 [14.4]	48.5 [14.2]	47.0 [13.8]	47.4 [13.9]	46.8 [13.7]	45.3 [13.3]
	Sens BTUH [kW]	33.6 [9.8]	32.5 [9.5]	30.0 [8.8]	39.4 [11.5]	38.2 [11.2]	35.1 [10.3]	43.6 [12.8]	42.3 [12.4]	38.9 [11.4]	44.8 [13.1]	43.4 [12.7]	40.3 [11.8]
	Power	3.1	3.1	3.1	3.1	3.1	3.1	3.1	3.1	3.1	3.1	3.1	3.1
85°F [29.4°C]	Total BTUH [kW]	55.2 [16.2]	54.6 [16.0]	52.9 [15.5]	51.1 [15.0]	50.5 [14.8]	48.9 [14.3]	47.4 [13.9]	46.9 [13.7]	45.4 [13.3]	45.8 [13.4]	45.2 [13.3]	43.7 [12.8]
	Sens BTUH [kW]	32.8 [9.6]	31.8 [9.3]	29.3 [8.6]	38.6 [11.3]	37.4 [11.0]	34.5 [10.1]	42.9 [12.6]	41.5 [12.2]	38.3 [11.2]	44.1 [12.9]	42.7 [12.5]	40.0 [11.7]
	Power	3.3	3.3	3.3	3.3	3.3	3.2	3.3	3.3	3.2	3.3	3.3	3.3
90°F [32.2°C]	Total BTUH [kW]	53.6 [15.7]	52.9 [15.5]	51.3 [15.0]	49.5 [14.5]	48.9 [14.3]	47.4 [13.9]	45.8 [13.4]	45.2 [13.3]	43.8 [12.8]	44.1 [12.9]	43.6 [12.8]	42.1 [12.3]
	Sens BTUH [kW]	32.1 [9.4]	31.1 [9.1]	28.6 [8.4]	37.9 [11.1]	36.7 [10.8]	33.8 [9.9]	42.1 [12.3]	40.8 [12.0]	37.6 [11.0]	43.3 [12.7]	41.9 [12.3]	42.1 [12.3]
	Power	3.5	3.5	3.4	3.5	3.5	3.4	3.5	3.5	3.4	3.5	3.5	3.5
95°F [35°C]	Total BTUH [kW]	51.9 [15.2]	51.3 [15.0]	49.7 [14.6]	47.8 [14.0]	47.2 [13.8]	45.8 [13.4]	44.1 [12.9]	43.6 [12.8]	42.2 [12.4]	42.5 [12.4]	42.0 [12.3]	40.4 [11.9]
	Sens BTUH [kW]	31.2 [9.2]	30.3 [8.9]	27.9 [8.2]	37.0 [10.9]	35.9 [10.5]	33.1 [9.7]	41.3 [12.1]	40.0 [11.7]	36.8 [10.8]	42.5 [12.4]	41.1 [12.1]	40.9 [12.0]
	Power	3.7	3.7	3.6	3.7	3.7	3.6	3.7	3.7	3.6	3.7	3.7	3.7
100°F [37.8°C]	Total BTUH [kW]	50.2 [14.7]	49.6 [14.5]	48.1 [14.1]	46.1 [13.5]	45.5 [13.3]	44.1 [12.9]	42.4 [12.4]	41.9 [12.3]	40.6 [11.9]	40.8 [12.0]	40.3 [11.8]	38.8 [11.4]
	Sens BTUH [kW]	30.4 [8.9]	29.4 [8.6]	27.1 [7.9]	36.2 [10.6]	35.0 [10.3]	32.3 [9.5]	40.4 [11.8]	39.1 [11.5]	36.0 [10.6]	40.8 [12.0]	39.3 [11.5]	38.8 [11.4]
	Power	3.9	3.9	3.9	3.9	3.9	3.8	3.9	3.9	3.8	3.9	3.9	3.9
105°F [40.6°C]	Total BTUH [kW]	48.5 [14.2]	47.9 [14.0]	46.5 [13.6]	44.4 [13.0]	43.9 [12.8]	42.5 [12.5]	40.7 [11.9]	40.2 [11.8]	39.0 [11.4]	39.1 [11.5]	38.6 [11.3]	37.1 [10.9]
	Sens BTUH [kW]	29.4 [8.6]	28.5 [8.4]	26.3 [7.7]	35.2 [10.3]	34.1 [10.0]	31.4 [9.2]	39.5 [11.6]	38.2 [11.2]	35.2 [10.3]	39.1 [11.5]	38.6 [11.3]	37.1 [10.9]
	Power	4.2	4.2	4.1	4.2	4.2	4.1	4.2	4.1	4.1	4.1	4.1	4.1
110°F [43.3°C]	Total BTUH [kW]	46.8 [13.7]	46.2 [13.5]	44.8 [13.1]	42.7 [12.5]	42.1 [12.3]	40.8 [12.0]	39.0 [11.4]	38.5 [11.3]	37.3 [10.9]	37.3 [10.9]	36.9 [10.8]	35.4 [10.4]
	Sens BTUH [kW]	28.5 [8.3]	27.6 [8.1]	25.4 [7.4]	34.3 [10.0]	33.2 [9.7]	30.6 [9.0]	38.5 [11.3]	37.3 [10.9]	34.3 [10.1]	37.3 [10.9]	36.9 [10.8]	35.4 [10.4]
	Power	4.4	4.4	4.3	4.4	4.4	4.3	4.4	4.4	4.3	4.4	4.4	4.4
115°F [46.1°C]	Total BTUH [kW]	45.0 [13.2]	44.5 [13.0]	43.1 [12.6]	40.9 [12.0]	40.4 [11.8]	39.2 [11.5]	37.2 [10.9]	36.8 [10.8]	35.7 [10.4]	35.6 [10.4]	35.2 [10.3]	33.6 [9.9]
	Sens BTUH [kW]	27.4 [8.0]	26.6 [7.8]	24.5 [7.2]	33.2 [9.7]	32.2 [9.4]	29.7 [8.7]	37.2 [10.9]	36.3 [10.6]	33.4 [9.8]	35.6 [10.4]	34.1 [10.0]	33.6 [9.9]
	Power	4.7	4.7	4.6	4.7	4.7	4.6	4.7	4.7	4.6	4.7	4.7	4.6
120°F [48.9°C]	Total BTUH [kW]	43.3 [12.7]	42.7 [12.5]	41.4 [12.1]	39.1 [11.5]	38.6 [11.3]	37.5 [11.0]	35.5 [10.4]	35.0 [10.3]	33.9 [9.9]	33.8 [9.9]	33.4 [9.8]	31.9 [9.3]
	Sens BTUH [kW]	26.4 [7.7]	25.5 [7.5]	23.5 [6.9]	32.2 [9.4]	31.2 [9.1]	28.7 [8.4]	35.5 [10.4]	35.0 [10.3]	32.5 [9.5]	33.8 [9.9]	33.4 [9.8]	31.9 [9.3]
	Power	5.0	4.9	4.9	5.0	4.9	4.9	5.0	4.9	4.9	4.9	4.9	4.9
125°F [51.7°C]	Total BTUH [kW]	41.5 [12.2]	41.0 [12.0]	39.7 [11.6]	37.3 [10.9]	36.9 [10.8]	35.7 [10.5]	33.7 [9.9]	33.2 [9.7]	32.2 [9.4]	32.0 [9.4]	31.6 [9.3]	30.1 [8.8]
	Sens BTUH [kW]	25.2 [7.4]	24.5 [7.2]	22.5 [6.6]	31.0 [9.1]	30.1 [8.8]	27.7 [8.1]	33.7 [9.9]	33.2 [9.7]	31.5 [9.2]	32.0 [9.4]	31.6 [9.3]	30.1 [8.8]
	Power	5.3	5.2	5.2	5.3	5.2	5.2	5.3	5.2	5.1	5.2	5.2	5.2

DR — Depression ratio  
dbE — Entering air dry bulb  
wB/E — Entering air wet bulb

Total capacity x 1000 BTUH  
Sens — Sensible capacity x 1000 BTUH  
Power — KW input

NOTES: ① When the entering air dry bulb is other than 80°F [27°C], adjust the sensible capacity from the table by adding [1.10 x CFM x (1 - DR) x (dbE - 80)].

[ ] Designates Metric Conversions

# HEATING PERFORMANCE DATA — RHPCZR048A

OUTDOOR DRY BULB TEMPERATURE °F [°C]	IDB			60°F [15.5°C]			70°F [21.1°C]			80°F [26.7°C]			
	CFM [L/s]	1800 [850]	1685 [795]	1400 [661]	1800 [850]	1685 [795]	1400 [661]	1800 [850]	1685 [795]	1400 [661]	1800 [850]	1685 [795]	1400 [661]
0°F [-17.8°C]	Total BTUH [kW] Power	13.3 [3.9] 3.1	13.2 [3.9] 3.1	13.0 [3.8] 3.2	12.8 [3.7] 3.2	12.7 [3.7] 3.2	12.6 [3.7] 3.3	12.3 [3.6] 4.0	12.3 [3.6] 4.1	12.1 [3.5] 4.2	12.3 [3.6] 4.1	12.3 [3.6] 4.2	12.1 [3.5] 4.2
5°F [-15.0°C]	Total BTUH [kW] Power	16.7 [4.9] 3.1	16.6 [4.9] 3.1	16.4 [4.8] 3.2	16.2 [4.8] 3.2	16.1 [4.7] 3.2	15.9 [4.7] 3.3	15.7 [4.6] 4.1	15.7 [4.6] 4.1	15.5 [4.5] 4.2	15.7 [4.6] 4.1	15.7 [4.6] 4.2	15.5 [4.5] 4.2
10°F [-12.2°C]	Total BTUH [kW] Power	20.1 [5.9] 3.1	20.0 [5.9] 3.2	19.8 [5.8] 3.2	19.6 [5.8] 3.2	19.5 [5.7] 3.3	19.3 [5.7] 3.3	19.2 [5.6] 4.1	19.1 [5.6] 4.1	18.9 [5.5] 4.2	19.2 [5.6] 4.1	19.1 [5.6] 4.2	18.9 [5.5] 4.2
15°F [-9.4°C]	Total BTUH [kW] Power	23.5 [6.9] 3.2	23.4 [6.9] 3.2	23.1 [6.8] 3.3	23.1 [6.8] 3.3	23.0 [6.7] 3.3	22.7 [6.6] 3.4	22.6 [6.6] 4.1	22.5 [6.6] 4.2	22.2 [6.5] 4.2	22.6 [6.6] 4.1	22.5 [6.6] 4.2	22.2 [6.5] 4.2
20°F [-6.7°C]	Total BTUH [kW] Power	27.0 [7.9] 3.2	26.8 [7.9] 3.2	26.5 [7.8] 3.3	26.5 [7.8] 3.3	26.4 [7.7] 3.3	26.1 [7.6] 3.4	26.0 [7.6] 4.2	25.9 [7.6] 4.2	25.6 [7.5] 4.3	26.0 [7.6] 4.2	25.9 [7.6] 4.2	25.6 [7.5] 4.3
25°F [-3.9°C]	Total BTUH [kW] Power	30.4 [8.9] 3.2	30.2 [8.9] 3.2	29.9 [8.8] 3.3	29.9 [8.8] 3.3	29.8 [8.7] 3.3	29.4 [8.6] 3.4	29.5 [8.6] 4.2	29.3 [8.6] 4.2	29.0 [8.5] 4.3	29.5 [8.6] 4.2	29.3 [8.6] 4.2	29.0 [8.5] 4.3
30°F [-1.1°C]	Total BTUH [kW] Power	33.8 [9.9] 3.2	33.7 [9.9] 3.3	33.3 [9.7] 3.3	33.4 [9.8] 3.3	33.2 [9.7] 3.4	32.8 [9.6] 3.4	32.9 [9.6] 4.2	32.7 [9.6] 4.2	32.3 [9.5] 4.3	32.9 [9.6] 4.2	32.7 [9.6] 4.2	32.3 [9.5] 4.3
35°F [1.7°C]	Total BTUH [kW] Power	37.2 [10.9] 3.3	37.1 [10.9] 3.3	36.6 [10.7] 3.4	36.8 [10.8] 3.4	36.6 [10.7] 3.4	36.2 [10.6] 3.5	36.3 [10.6] 4.2	36.1 [10.6] 4.3	35.7 [10.5] 4.4	36.3 [10.6] 4.2	36.1 [10.6] 4.3	35.7 [10.5] 4.4
40°F [4.4°C]	Total BTUH [kW] Power	40.7 [11.9] 3.3	40.5 [11.9] 3.3	40.0 [11.7] 3.4	40.2 [11.8] 3.4	40.0 [11.7] 3.4	39.5 [11.6] 3.5	39.7 [11.6] 4.3	39.6 [11.6] 4.3	39.1 [11.5] 4.4	39.7 [11.6] 4.3	39.6 [11.6] 4.3	39.1 [11.5] 4.4
45°F [7.2°C]	Total BTUH [kW] Power	44.1 [12.9] 3.3	43.9 [12.9] 3.4	43.4 [12.7] 3.4	43.6 [12.8] 3.4	43.4 [12.7] 3.5	42.9 [12.6] 3.5	43.2 [12.7] 4.3	43.0 [12.6] 4.3	42.4 [12.4] 4.4	43.2 [12.7] 4.3	43.0 [12.6] 4.3	42.4 [12.4] 4.4
50°F [10.0°C]	Total BTUH [kW] Power	47.5 [13.9] 3.4	47.3 [13.9] 3.4	46.7 [13.7] 3.5	47.1 [13.8] 3.4	46.8 [13.7] 3.5	46.3 [13.6] 3.6	46.6 [13.7] 4.3	46.4 [13.6] 4.4	45.8 [13.4] 4.4	46.6 [13.7] 4.3	46.4 [13.6] 4.4	45.8 [13.4] 4.4

IDB—Indoor air dry bulb

[ ] Designates Metric Conversions

# COOLING PERFORMANCE DATA — RHPCZR060A

wB/E		ENTERING INDOOR AIR @ 80°F [26.7°C] dbE ①														
		71°F [21.7°C]		67°F [19.4°C]		63°F [17.2°C]		61°F [16.1°C]		59°F [15.0°C]						
CFM [L/s]	DR ①	2250 [1062]	2050 [967]	1750 [826]	2250 [1062]	2050 [967]	1750 [826]	2250 [1062]	2050 [967]	1750 [826]	2250 [1062]	2050 [967]	1750 [826]	2250 [1062]	2050 [967]	1750 [826]
75°F [23.9°C]	Total BTUH [kW]	75.4 [22.1]	74.1 [21.7]	72.1 [21.1]	69.6 [20.4]	68.4 [20.0]	66.6 [19.5]	64.2 [18.8]	63.1 [18.5]	61.4 [18.0]	61.6 [18.1]	60.5 [17.7]	58.9 [17.3]	59.1 [17.3]	58.1 [17.0]	56.5 [16.6]
	Sens BTUH [kW]	46.2 [13.5]	44.2 [12.9]	41.1 [12.1]	51.9 [15.2]	49.6 [14.5]	46.2 [13.5]	54.7 [16.0]	52.3 [15.3]	48.8 [14.3]	55.1 [16.1]	52.7 [15.4]	49.1 [14.4]	54.8 [16.1]	52.4 [15.4]	48.8 [14.3]
	Power	3.4	3.4	3.3	3.4	3.3	3.3	3.3	3.3	3.3	3.3	3.3	3.2	3.3	3.3	3.2
80°F [26.7°C]	Total BTUH [kW]	73.3 [21.5]	72.0 [21.1]	70.1 [20.5]	67.5 [19.8]	66.3 [19.4]	64.6 [18.9]	62.1 [18.2]	61.0 [17.9]	59.4 [17.4]	59.5 [17.4]	58.5 [17.1]	56.9 [16.7]	57.0 [16.7]	56.0 [16.4]	54.5 [16.0]
	Sens BTUH [kW]	45.1 [13.2]	43.1 [12.6]	40.2 [11.8]	50.8 [14.9]	48.5 [14.2]	45.2 [13.3]	53.6 [15.7]	51.3 [15.0]	47.8 [14.0]	54.0 [15.8]	51.7 [15.1]	48.1 [14.1]	53.7 [15.7]	51.3 [15.0]	47.8 [14.0]
	Power	3.6	3.6	3.5	3.6	3.5	3.5	3.5	3.5	3.5	3.5	3.5	3.4	3.5	3.5	3.4
85°F [29.4°C]	Total BTUH [kW]	71.1 [20.8]	69.8 [20.5]	68.0 [19.9]	65.3 [19.1]	64.2 [18.8]	62.5 [18.3]	60.2 [17.7]	58.8 [17.2]	57.3 [16.8]	57.3 [16.8]	56.3 [16.5]	54.8 [16.1]	54.8 [16.1]	53.8 [15.8]	52.4 [15.4]
	Sens BTUH [kW]	43.9 [12.9]	42.0 [12.3]	39.1 [11.5]	49.6 [14.5]	47.4 [13.9]	44.2 [12.9]	52.5 [15.4]	50.2 [14.7]	46.7 [13.7]	52.8 [15.5]	50.5 [14.8]	47.1 [13.8]	52.5 [15.4]	50.2 [14.7]	46.8 [13.7]
	Power	3.9	3.8	3.8	3.8	3.8	3.7	3.8	3.7	3.7	3.8	3.7	3.7	3.7	3.7	3.6
90°F [32.2°C]	Total BTUH [kW]	68.7 [20.1]	67.5 [19.8]	65.7 [19.3]	63.0 [18.5]	61.9 [18.1]	60.2 [17.7]	57.9 [17.0]	56.6 [16.6]	55.1 [16.1]	55.0 [16.1]	54.0 [15.8]	52.6 [15.4]	52.6 [15.4]	51.6 [15.1]	50.2 [14.7]
	Sens BTUH [kW]	42.7 [12.5]	40.8 [12.0]	38.0 [11.1]	48.3 [14.2]	46.2 [13.6]	43.1 [12.6]	51.2 [15.0]	49.0 [14.4]	45.6 [13.4]	51.6 [15.1]	49.3 [14.5]	46.0 [13.5]	51.3 [15.0]	49.0 [14.4]	45.7 [13.4]
	Power	4.1	4.1	4.1	4.1	4.1	4.0	4.1	4.0	4.0	4.0	4.0	3.9	4.0	4.0	3.9
95°F [35°C]	Total BTUH [kW]	66.3 [19.4]	65.1 [19.1]	63.4 [18.6]	60.5 [17.7]	59.5 [17.4]	57.9 [17.0]	55.4 [16.2]	54.2 [15.9]	52.7 [15.4]	52.5 [15.4]	51.6 [15.1]	50.2 [14.7]	50.2 [14.7]	49.2 [14.4]	47.8 [14.0]
	Sens BTUH [kW]	41.4 [12.1]	39.6 [11.6]	36.9 [10.8]	47.0 [13.8]	45.0 [13.2]	41.9 [12.3]	49.9 [14.6]	47.7 [14.0]	44.5 [13.0]	50.3 [14.7]	48.1 [14.1]	44.8 [13.1]	50.0 [14.6]	47.8 [14.0]	44.5 [13.0]
	Power	4.5	4.4	4.4	4.4	4.4	4.3	4.4	4.3	4.3	4.3	4.3	4.3	4.3	4.3	4.2
100°F [37.8°C]	Total BTUH [kW]	63.7 [18.7]	62.6 [18.3]	60.9 [17.9]	58.0 [17.0]	57.0 [16.7]	55.4 [16.2]	52.5 [15.4]	51.6 [15.1]	50.3 [14.7]	50.0 [14.6]	49.1 [14.4]	47.8 [14.0]	47.8 [14.0]	46.6 [13.7]	45.4 [13.3]
	Sens BTUH [kW]	40.0 [11.7]	38.2 [11.2]	35.6 [10.4]	45.7 [13.4]	43.7 [12.8]	40.7 [11.9]	48.6 [14.2]	46.4 [13.6]	43.3 [12.7]	48.9 [14.3]	46.8 [13.7]	43.6 [12.8]	47.5 [13.9]	46.5 [13.6]	43.3 [12.7]
	Power	4.8	4.8	4.7	4.8	4.7	4.7	4.7	4.7	4.6	4.7	4.7	4.6	4.7	4.6	4.6
105°F [40.6°C]	Total BTUH [kW]	61.0 [17.9]	60.0 [17.6]	58.4 [17.1]	55.3 [16.2]	54.3 [15.9]	52.9 [15.5]	50.2 [14.7]	49.0 [14.4]	47.7 [14.0]	47.3 [13.9]	46.4 [13.6]	45.2 [13.2]	44.8 [13.1]	44.0 [12.9]	42.8 [12.5]
	Sens BTUH [kW]	38.6 [11.3]	36.9 [10.8]	34.4 [10.1]	44.2 [13.0]	42.3 [12.4]	39.4 [11.6]	47.1 [13.8]	45.1 [13.2]	42.0 [12.3]	47.3 [13.9]	45.4 [13.3]	42.3 [12.4]	44.8 [13.1]	44.0 [12.9]	42.0 [12.3]
	Power	5.2	5.2	5.1	5.2	5.1	5.1	5.1	5.1	5.0	5.1	5.1	5.0	5.1	5.0	5.0
110°F [43.3°C]	Total BTUH [kW]	58.2 [17.1]	57.2 [16.8]	55.7 [16.3]	52.5 [15.4]	51.5 [15.1]	50.2 [14.7]	47.0 [13.8]	46.2 [13.5]	44.5 [13.0]	44.5 [13.0]	43.7 [12.8]	42.5 [12.5]	42.0 [12.3]	41.2 [12.1]	40.1 [11.8]
	Sens BTUH [kW]	37.1 [10.9]	35.4 [10.4]	33.0 [9.7]	42.7 [12.5]	40.9 [12.0]	38.1 [11.2]	45.6 [13.4]	43.6 [12.8]	40.7 [11.9]	44.5 [13.0]	43.7 [12.8]	41.0 [12.0]	42.0 [12.3]	41.2 [12.1]	40.1 [11.8]
	Power	5.6	5.6	5.5	5.6	5.6	5.5	5.6	5.5	5.4	5.5	5.5	5.4	5.5	5.5	5.4
115°F [46.1°C]	Total BTUH [kW]	55.3 [16.2]	54.3 [15.9]	52.9 [15.5]	49.5 [14.5]	48.7 [14.3]	47.4 [13.9]	44.1 [12.9]	43.3 [12.7]	42.2 [12.4]	41.5 [12.2]	40.8 [12.0]	39.7 [11.6]	39.0 [11.4]	38.3 [11.2]	37.3 [10.9]
	Sens BTUH [kW]	35.5 [10.4]	33.9 [9.9]	31.6 [9.3]	41.2 [12.1]	39.4 [11.5]	36.7 [10.8]	44.1 [12.9]	42.1 [12.3]	39.3 [11.5]	41.5 [12.2]	40.8 [12.0]	39.6 [11.6]	39.0 [11.4]	38.3 [11.2]	37.3 [10.9]
	Power	6.1	6.1	6.0	6.1	6.0	5.9	6.0	6.0	5.9	6.0	5.9	5.9	6.0	5.9	5.8
120°F [48.9°C]	Total BTUH [kW]	52.2 [15.3]	51.3 [15.0]	50.0 [14.6]	46.5 [13.6]	45.7 [13.4]	44.5 [13.0]	41.1 [12.0]	40.3 [11.8]	39.3 [11.5]	38.5 [11.3]	37.8 [11.1]	36.8 [10.8]	36.0 [10.5]	35.3 [10.4]	34.4 [10.1]
	Sens BTUH [kW]	33.9 [9.9]	32.4 [9.5]	30.2 [8.8]	39.6 [11.6]	37.8 [11.1]	35.2 [10.3]	41.1 [12.0]	40.3 [11.8]	37.8 [11.1]	38.5 [11.3]	37.8 [11.1]	36.8 [10.8]	36.0 [10.5]	35.3 [10.4]	34.4 [10.1]
	Power	6.6	6.6	6.5	6.6	6.5	6.4	6.5	6.5	6.4	6.5	6.4	6.4	6.5	6.4	6.3
125°F [51.7°C]	Total BTUH [kW]	49.1 [14.4]	48.2 [14.1]	46.9 [13.8]	43.3 [12.7]	42.6 [12.5]	41.4 [12.1]	37.9 [11.1]	37.2 [10.9]	36.2 [10.6]	35.3 [10.3]	34.7 [10.2]	33.8 [9.9]	32.8 [9.6]	32.2 [9.4]	31.4 [9.2]
	Sens BTUH [kW]	32.2 [9.4]	30.8 [9.0]	28.7 [8.4]	37.9 [11.1]	36.2 [10.6]	33.7 [9.9]	37.9 [11.1]	37.2 [10.9]	36.2 [10.6]	35.3 [10.3]	34.7 [10.2]	33.8 [9.9]	32.8 [9.6]	32.2 [9.4]	31.4 [9.2]
	Power	7.2	7.1	7.0	7.1	7.1	7.0	7.1	7.0	6.9	7.0	7.0	6.9	6.9	6.9	6.9

DR — Depression ratio  
 dbE — Entering air dry bulb  
 wB/E — Entering air wet bulb

① When the entering air dry bulb is other than 80°F [27°C], adjust the sensible capacity from the table by adding [1.10 x CFM x (1 - DR) x (dbE - 80)].

[ ] Designates Metric Conversions



# HEATING PERFORMANCE DATA — RHPCZR060A

OUTDOOR DRY BULB TEMPERATURE °F [°C]	IDB			60°F [15.5°C]			70°F [21.1°C]			80°F [26.7°C]			
	CFM [L/s]	2250 [1062]	2050 [967]	1750 [826]	2250 [1062]	2050 [967]	1750 [826]	2250 [1062]	2050 [967]	1750 [826]	2250 [1062]	2050 [967]	1750 [826]
0°F [-17.8°C]	Total BTUH [kW]	23.3 [6.8]	23.2 [6.8]	22.9 [6.7]	22.3 [6.5]	22.1 [6.5]	21.9 [6.4]	21.2 [6.2]	21.1 [6.2]	20.9 [6.1]	21.2 [6.2]	21.1 [6.2]	20.9 [6.1]
	Power	5.0	5.0	5.1	5.1	5.1	5.2	6.1	6.2	6.3	6.1	6.2	6.3
5°F [-15.0°C]	Total BTUH [kW]	26.9 [7.9]	26.7 [7.8]	26.4 [7.7]	25.9 [7.6]	25.7 [7.5]	25.4 [7.4]	24.8 [7.3]	24.6 [7.2]	24.4 [7.1]	24.8 [7.3]	24.6 [7.2]	24.4 [7.1]
	Power	4.9	4.9	5.0	5.0	5.1	5.2	6.0	6.1	6.2	6.0	6.1	6.2
10°F [-12.2°C]	Total BTUH [kW]	30.5 [8.9]	30.3 [8.9]	29.9 [8.8]	29.4 [8.6]	29.2 [8.6]	28.9 [8.5]	28.4 [8.3]	28.2 [8.3]	27.9 [8.2]	28.4 [8.3]	28.2 [8.3]	27.9 [8.2]
	Power	4.8	4.9	5.0	4.9	5.0	5.1	6.0	6.0	6.1	6.0	6.0	6.1
15°F [-9.4°C]	Total BTUH [kW]	34.1 [10.0]	33.8 [9.9]	33.5 [9.8]	33.0 [9.7]	32.8 [9.6]	32.4 [9.5]	32.0 [9.4]	31.7 [9.3]	31.4 [9.2]	32.0 [9.4]	31.7 [9.3]	31.4 [9.2]
	Power	4.8	4.8	4.9	4.9	4.9	5.0	5.9	6.0	6.1	5.9	6.0	6.1
20°F [-6.7°C]	Total BTUH [kW]	37.6 [11.0]	37.4 [11.0]	37.0 [10.8]	36.6 [10.7]	36.3 [10.6]	36.0 [10.5]	35.5 [10.4]	35.3 [10.3]	34.9 [10.2]	35.5 [10.4]	35.3 [10.3]	34.9 [10.2]
	Power	4.7	4.8	4.8	4.8	4.9	5.0	5.8	5.9	6.0	5.8	5.9	6.0
25°F [-3.9°C]	Total BTUH [kW]	41.2 [12.1]	40.9 [12.0]	40.5 [11.9]	40.2 [11.8]	39.9 [11.7]	39.5 [11.6]	39.1 [11.5]	38.9 [11.4]	38.4 [11.3]	39.1 [11.5]	38.9 [11.4]	38.4 [11.3]
	Power	4.6	4.7	4.8	4.7	4.8	4.9	5.8	5.8	5.9	5.8	5.8	5.9
30°F [-1.1°C]	Total BTUH [kW]	44.8 [13.1]	44.5 [13.0]	44.0 [12.9]	43.7 [12.8]	43.4 [12.7]	43.0 [12.6]	42.7 [12.5]	42.4 [12.4]	42.0 [12.3]	42.7 [12.5]	42.4 [12.4]	42.0 [12.3]
	Power	4.6	4.6	4.7	4.7	4.7	4.8	5.7	5.8	5.9	5.7	5.8	5.9
35°F [1.7°C]	Total BTUH [kW]	48.4 [14.2]	48.0 [14.1]	47.5 [13.9]	47.3 [13.9]	47.0 [13.8]	46.5 [13.6]	46.3 [13.6]	46.0 [13.5]	45.5 [13.3]	46.3 [13.6]	46.0 [13.5]	45.5 [13.3]
	Power	4.5	4.6	4.6	4.6	4.7	4.8	5.6	5.7	5.8	5.6	5.7	5.8
40°F [4.4°C]	Total BTUH [kW]	51.9 [15.2]	51.6 [15.1]	51.0 [15.0]	50.9 [14.9]	50.5 [14.8]	50.0 [14.7]	49.9 [14.6]	49.5 [14.5]	49.0 [14.4]	49.9 [14.6]	49.5 [14.5]	49.0 [14.4]
	Power	4.4	4.5	4.6	4.5	4.6	4.7	5.6	5.6	5.7	5.6	5.6	5.7
45°F [7.2°C]	Total BTUH [kW]	55.5 [16.3]	55.1 [16.2]	54.6 [16.0]	54.5 [16.0]	54.1 [15.9]	53.5 [15.7]	53.4 [15.7]	53.1 [15.6]	52.5 [15.4]	53.4 [15.7]	53.1 [15.6]	52.5 [15.4]
	Power	4.4	4.4	4.5	4.5	4.5	4.6	5.5	5.6	5.7	5.5	5.6	5.7
50°F [10.0°C]	Total BTUH [kW]	59.1 [17.3]	58.7 [17.2]	58.1 [17.0]	58.1 [17.0]	57.7 [16.9]	57.0 [16.7]	57.0 [16.7]	56.6 [16.6]	56.0 [16.4]	57.0 [16.7]	56.6 [16.6]	56.0 [16.4]
	Power	4.3	4.4	4.4	4.4	4.5	4.6	5.4	5.5	5.6	5.4	5.5	5.6

IDB—Indoor air dry bulb

[ ] Designates Metric Conversions

# COOLING PERFORMANCE DATA – RHPCZT072A

wB/E		ENTERING INDOOR AIR @ 80°F [26.7°C] dbE ①											
		71°F [21.7°C]		67°F [19.4°C]		63°F [17.2°C]		61°F [16.1°C]		59°F [15.0°C]			
CFM [L/s]	DR ①	2700 [1274]	2400 [1133]	2100 [991]	2700 [1274]	2400 [1133]	2100 [991]	2700 [1274]	2400 [1133]	2100 [991]	2700 [1274]	2400 [1133]	2100 [991]
75°F [23.9°C]	Total BTUH [kW]	90.5 [26.5]	88.5 [25.9]	86.5 [25.3]	84.2 [24.7]	82.3 [24.1]	80.4 [23.6]	78.7 [23.1]	76.9 [22.5]	75.2 [22.0]	74.5 [21.8]	72.9 [21.3]	71.2 [20.9]
	Sens BTUH [kW]	53.4 [15.6]	50.4 [14.8]	47.5 [13.9]	65.3 [19.1]	61.7 [18.1]	58.1 [17.0]	74.4 [21.8]	70.3 [20.6]	66.2 [19.4]	74.5 [21.8]	70.9 [20.6]	68.1 [20.0]
	Power	4.1	4.1	4.0	4.0	4.0	3.9	4.0	3.9	3.9	3.9	3.9	3.8
80°F [26.7°C]	Total BTUH [kW]	87.5 [25.6]	85.6 [25.1]	83.6 [24.5]	81.2 [23.8]	79.4 [23.3]	77.6 [22.7]	75.7 [22.2]	74.0 [21.7]	72.3 [21.2]	71.6 [21.0]	70.0 [20.5]	68.4 [20.0]
	Sens BTUH [kW]	50.8 [14.9]	48.0 [14.1]	45.2 [13.2]	62.7 [18.4]	59.3 [17.4]	55.8 [16.4]	71.8 [21.0]	67.9 [19.9]	63.9 [18.7]	71.6 [21.0]	68.1 [20.5]	65.3 [19.2]
	Power	4.4	4.3	4.3	4.3	4.3	4.2	4.2	4.2	4.2	4.2	4.1	4.1
85°F [29.4°C]	Total BTUH [kW]	84.5 [24.8]	82.6 [24.2]	80.8 [23.7]	78.2 [22.9]	76.5 [22.4]	74.7 [21.9]	72.7 [21.3]	71.1 [20.8]	69.5 [20.4]	68.8 [20.2]	67.0 [19.6]	65.5 [19.2]
	Sens BTUH [kW]	48.3 [14.2]	45.7 [13.4]	43.0 [12.6]	60.3 [17.7]	56.9 [16.7]	53.6 [15.7]	69.4 [20.3]	65.5 [19.2]	61.7 [18.1]	68.4 [20.0]	64.5 [19.6]	61.7 [18.3]
	Power	4.7	4.6	4.6	4.6	4.6	4.5	4.5	4.5	4.4	4.5	4.4	4.4
90°F [32.2°C]	Total BTUH [kW]	81.5 [23.9]	79.6 [23.3]	77.8 [22.8]	75.1 [22.0]	73.5 [21.5]	71.8 [21.0]	69.6 [20.4]	68.1 [20.0]	66.5 [19.5]	65.9 [19.3]	64.0 [18.8]	62.6 [18.3]
	Sens BTUH [kW]	46.0 [13.5]	43.5 [12.7]	40.9 [12.0]	57.9 [17.0]	54.7 [16.0]	51.5 [15.1]	67.4 [19.7]	63.3 [18.6]	59.6 [17.5]	65.5 [19.2]	61.5 [18.8]	58.7 [18.3]
	Power	5.0	4.9	4.9	4.9	4.9	4.8	4.8	4.8	4.8	4.8	4.8	4.7
95°F [35°C]	Total BTUH [kW]	78.3 [23.0]	76.6 [22.4]	74.9 [21.9]	72.0 [21.1]	70.4 [20.6]	68.8 [20.2]	66.5 [19.5]	65.0 [19.1]	63.6 [18.6]	62.8 [18.4]	61.0 [17.9]	59.6 [17.5]
	Sens BTUH [kW]	43.8 [12.8]	41.4 [12.1]	38.9 [11.4]	55.7 [16.3]	52.6 [15.4]	49.6 [14.5]	64.8 [19.0]	61.2 [17.9]	57.6 [16.9]	62.8 [18.4]	58.4 [17.7]	55.6 [16.6]
	Power	5.3	5.3	5.2	5.3	5.2	5.2	5.2	5.1	5.1	5.1	5.1	5.0
100°F [37.8°C]	Total BTUH [kW]	75.2 [22.0]	73.5 [21.5]	71.8 [21.0]	68.9 [20.2]	67.3 [19.7]	65.8 [19.3]	63.4 [18.6]	62.0 [18.2]	60.5 [17.7]	59.7 [17.5]	57.9 [17.0]	56.6 [16.6]
	Sens BTUH [kW]	41.7 [12.2]	39.4 [11.5]	37.1 [10.9]	53.6 [15.7]	50.6 [14.8]	47.7 [14.0]	62.7 [18.4]	59.2 [17.4]	55.8 [16.3]	58.4 [17.1]	54.0 [16.4]	51.2 [15.3]
	Power	5.7	5.7	5.6	5.7	5.6	5.5	5.6	5.5	5.5	5.5	5.5	5.4
105°F [40.6°C]	Total BTUH [kW]	72.0 [21.1]	70.4 [20.6]	68.8 [20.1]	65.6 [19.2]	64.2 [18.8]	62.7 [18.4]	60.1 [17.6]	58.8 [17.2]	57.5 [16.8]	56.0 [16.4]	54.7 [16.0]	53.5 [15.7]
	Sens BTUH [kW]	39.7 [11.6]	37.5 [11.0]	35.3 [10.3]	51.6 [15.1]	48.8 [14.3]	45.9 [13.5]	60.1 [17.6]	57.3 [16.8]	54.0 [15.8]	56.0 [16.4]	51.5 [15.1]	48.8 [14.8]
	Power	6.1	6.0	6.0	6.0	6.0	5.9	6.0	5.9	5.9	5.9	5.9	5.8
110°F [43.3°C]	Total BTUH [kW]	68.7 [20.1]	67.2 [19.7]	65.6 [19.2]	62.4 [18.3]	61.0 [17.9]	59.6 [17.5]	56.9 [16.7]	55.6 [16.3]	54.3 [15.9]	52.2 [15.3]	52.7 [15.4]	50.4 [14.8]
	Sens BTUH [kW]	37.8 [11.1]	35.7 [10.5]	33.6 [9.9]	49.7 [14.6]	47.0 [13.8]	44.2 [13.0]	56.9 [16.7]	53.6 [15.3]	50.3 [14.5]	52.2 [15.3]	47.5 [14.5]	44.8 [14.8]
	Power	6.5	6.5	6.4	6.5	6.4	6.3	6.4	6.3	6.3	6.3	6.3	6.2
115°F [46.1°C]	Total BTUH [kW]	65.4 [19.2]	63.9 [18.7]	62.5 [18.3]	59.0 [17.3]	57.7 [16.9]	56.4 [16.5]	53.5 [15.7]	52.4 [15.3]	51.2 [15.0]	49.0 [14.4]	48.3 [14.1]	47.2 [13.8]
	Sens BTUH [kW]	36.1 [10.6]	34.1 [10.0]	32.1 [9.4]	48.0 [14.1]	45.3 [13.3]	42.7 [12.5]	53.5 [15.7]	50.8 [14.9]	47.5 [14.0]	49.0 [14.4]	44.5 [13.5]	41.8 [12.9]
	Power	7.0	6.9	6.8	6.9	6.8	6.8	6.8	6.8	6.7	6.7	6.7	6.6
120°F [48.9°C]	Total BTUH [kW]	62.0 [18.2]	60.6 [17.8]	59.2 [17.4]	55.7 [16.3]	54.4 [16.0]	53.2 [15.6]	50.2 [14.7]	49.1 [14.4]	47.9 [14.0]	46.0 [13.5]	45.0 [13.2]	44.0 [12.9]
	Sens BTUH [kW]	34.4 [10.1]	32.5 [9.5]	30.6 [9.0]	46.4 [13.6]	43.8 [12.8]	41.2 [12.1]	50.2 [14.7]	47.9 [14.0]	45.8 [13.4]	46.0 [13.5]	41.8 [12.9]	39.1 [12.3]
	Power	7.4	7.4	7.3	7.4	7.3	7.3	7.3	7.2	7.1	7.2	7.2	7.1
125°F [51.7°C]	Total BTUH [kW]	58.6 [17.2]	57.3 [16.8]	56.0 [16.4]	52.2 [15.3]	51.1 [15.0]	49.9 [14.6]	46.7 [13.7]	45.7 [13.4]	44.7 [13.1]	42.5 [12.7]	41.6 [12.2]	40.7 [11.9]
	Sens BTUH [kW]	32.9 [9.6]	31.1 [9.1]	29.3 [8.6]	44.8 [13.1]	42.4 [12.4]	39.9 [11.7]	46.7 [13.7]	44.5 [13.0]	42.5 [12.4]	42.6 [12.5]	38.1 [11.5]	35.4 [10.9]
	Power	7.9	7.8	7.8	7.9	7.8	7.7	7.8	7.7	7.6	7.7	7.6	7.6

DR — Depression ratio  
dbE — Entering air dry bulb  
wB/E — Entering air wet bulb

Total — Total capacity x 1000 BTUH  
Sens — Sensible capacity x 1000 BTUH  
Power — kW input

NOTES: ① When the entering air dry bulb is other than 80°F [27°C], adjust the sensible capacity from the table by adding [1.10 x CFM x (1 - DR) x (dbE - 80)].

[ ] Designates Metric Conversions

# HEATING PERFORMANCE DATA — RHPCZT072A

OUTDOOR DRY BULB TEMPERATURE [°F]	IDB		60°F [15.5°C]		70°F [21.1°C]		80°F [26.7°C]	
	CFM [L/s]	Power	2250 [1062]	1750 [826]	2250 [1062]	1750 [826]	2250 [1062]	1750 [826]
0°F [-17.8°C]	Total BTUH [kW]	Power	12.5 [3.7] 4.0	12.3 [3.6] 4.1	9.7 [2.8] 4.5	9.6 [2.8] 4.6	6.9 [2.0] 5.2	6.7 [2.0] 5.3
5°F [-15.0°C]	Total BTUH [kW]	Power	18.5 [5.4] 4.1	18.2 [5.3] 4.2	15.7 [4.6] 4.6	15.6 [4.6] 4.7	12.9 [3.8] 5.2	12.6 [3.7] 5.4
10°F [-12.2°C]	Total BTUH [kW]	Power	24.5 [7.2] 4.1	24.1 [7.1] 4.2	21.7 [6.4] 4.7	21.5 [6.3] 4.7	18.9 [5.5] 5.3	18.5 [5.4] 5.4
15°F [-9.4°C]	Total BTUH [kW]	Power	30.6 [9.0] 4.2	30.0 [8.8] 4.3	27.7 [8.1] 4.7	27.5 [8.1] 4.8	24.9 [7.3] 5.3	24.4 [7.2] 5.5
20°F [-6.7°C]	Total BTUH [kW]	Power	36.6 [10.7] 4.2	35.9 [10.5] 4.3	33.7 [9.9] 4.8	33.4 [9.8] 4.8	30.9 [9.1] 5.4	30.3 [8.9] 5.6
25°F [-3.9°C]	Total BTUH [kW]	Power	42.6 [12.5] 4.3	41.8 [12.3] 4.4	39.7 [11.6] 4.8	39.4 [11.5] 4.9	36.9 [10.8] 5.4	36.2 [10.6] 5.6
30°F [-1.1°C]	Total BTUH [kW]	Power	48.6 [14.2] 4.3	47.7 [14.0] 4.5	45.7 [13.4] 4.9	45.3 [13.3] 5.0	42.9 [12.6] 5.5	42.1 [12.3] 5.7
35°F [1.7°C]	Total BTUH [kW]	Power	54.6 [16.0] 4.4	53.6 [15.7] 4.5	51.7 [15.2] 4.9	51.3 [15.0] 5.0	48.9 [14.3] 5.5	48.0 [14.1] 5.7
40°F [4.4°C]	Total BTUH [kW]	Power	60.6 [17.8] 4.4	59.5 [17.4] 4.6	57.8 [16.9] 5.0	57.2 [16.8] 5.1	54.9 [16.1] 5.6	53.9 [15.8] 5.8
45°F [7.2°C]	Total BTUH [kW]	Power	66.6 [19.5] 4.5	65.4 [19.2] 4.6	63.8 [18.7] 5.0	63.2 [18.5] 5.1	60.9 [17.9] 5.7	59.8 [17.5] 5.8
50°F [10.0°C]	Total BTUH [kW]	Power	72.6 [21.3] 4.5	71.3 [20.9] 4.7	69.8 [20.4] 5.1	69.1 [20.3] 5.2	66.9 [19.6] 5.7	65.7 [19.3] 5.9

IDB—Indoor air dry bulb

[ ] Designates Metric Conversions

### 3-6T – LOW STATIC – SIDEFLOW (208-230V)

Unit Model (Tonnage)	Manufacturer Recommended Airflow Range (Min/Max) CFM	COMPONENT AIRFLOW RESISTANCE		Motor HP [W]	Motor Speed	CFM/ WATTS	External Static Pressure - Inches W.C. [kPa]							
		Pressure Drop MERV 8	Pressure Drop MERV 13				0.1 [.02]	0.2 [.05]	0.3 [.07]	0.4 [.10]	0.5 [.12]	0.6 [.15]	0.7 [.17]	0.8 [.20]
		Resistance - Inches of Water (Min/Max) [kPa]												
RHPCZR036 (3T)	1050/1350	0.075 [.02]/ 0.105 [.03]	0.020 [.00]/ 0.066 [.02]	3/4 HP [559]	Fan - Tap 1	CFM	895	809	730	642	555	497	420	367
						WATTS	52	59	66	73	79	80	85	86
				3/4 HP [559]	Tap 2	CFM	1189	1111	1041	964	889	832	763	711
						WATTS	145	153	162	171	179	184	192	197
				3/4 HP [559]	Tap 3	CFM	1370	1297	1232	1163	1095	1038	974	922
						WATTS	201	211	221	231	240	248	257	264
				3/4 HP [559]	Cooling - Tap 4 *	CFM	1170	1091	1020	943	867	810	740	688
						WATTS	138	147	156	164	172	177	185	189
				3/4 HP [559]	High Speed - Tap 5	CFM	1513	1445	1389	1322	1269	1210	1153	1097
						WATTS	232	242	252	264	275	285	295	302
RHPCZR048 (4T)	1400/1800	0.110 [.03]/ 0.150 [.04]	0.074 [.02]/ 0.135 [.03]	3/4 HP [559]	Fan - Tap 1	CFM	895	809	730	642	555	497	420	367
						WATTS	52	59	66	73	79	80	85	86
				3/4 HP [559]	Tap 2	CFM	1288	1212	1144	1072	1001	944	878	825
						WATTS	175	185	194	203	212	219	227	233
				3/4 HP [559]	Tap 3	CFM	1567	1499	1439	1378	1318	1261	1203	1151
						WATTS	263	274	285	296	306	317	328	338
				3/4 HP [559]	Cooling - Tap 4 *	CFM	1507	1438	1376	1313	1250	1193	1133	1081
						WATTS	244	255	265	276	286	296	307	316
				3/4 HP [559]	High Speed - Tap 5	CFM	1876	1817	1766	1718	1671	1614	1564	1512
						WATTS	360	373	386	399	411	427	440	454
RHPCZR060 (5T)	1750/2250	0.145 [.04]/ 0.195 [.05]	0.128 [.03]/ 0.205 [.05]	1 HP [745]	Fan - Tap 1	CFM	1169	1092	1022	950	874	783	715	640
						WATTS	129	138	147	158	165	173	180	187
				1 HP [745]	Tap 2	CFM	1586	1519	1459	1399	1339	1279	1221	1161
						WATTS	283	294	305	316	329	340	351	361
				1 HP [745]	Tap 3	CFM	1852	1794	1738	1684	1628	1575	1523	1471
						WATTS	437	450	463	476	491	503	516	529
				1 HP [745]	Cooling - Tap 4 *	CFM	1954	1899	1845	1792	1739	1688	1639	1590
						WATTS	496	510	524	537	553	566	580	594
				1 HP [745]	High Speed - Tap 5	CFM	2298	2254	2199	2154	2106	2059	2014	1976
						WATTS	929	956	981	1001	1030	1056	1081	1105
(-)HPCZT072 (6T)	2100/2700	0.180 [.04]/ 0.240 [.06]	0.182 [.04]/ 0.275 [.07]	1.2 HP [895]	Fan/Low Heat - Tap 1	CFM	1384	1319	1249	1188	1127	1066	1006	947
						WATTS	192	204	215	225	240	245	255	265
				1.2 HP [895]	High Heat - Tap 2	CFM	1874	1833	1778	1730	1680	1630	1584	1539
						WATTS	421	435	450	466	480	495	510	525
				1.2 HP [895]	Low Cool - Tap 3	CFM	1546	1488	1427	1372	1316	1261	1203	1149
						WATTS	258	270	282	298	310	318	330	338
				1.2 HP [895]	High Cool - Tap 4	CFM	2331	2290	2245	2204	2159	2118	2072	2036
						WATTS	700	718	730	745	760	782	797	820
				1.2 HP [895]	High Speed - Tap 5	CFM	2363	2330	2280	2237	2198	2164	2110	2071
						WATTS	771	792	808	824	843	860	875	890

NOTES: \* Tap 4 - Factory Cooling Tap  
 Pressure drops across the 3-5T CFM range (1050 - 2250)  
 Pressure drops across the 6T CFM range  
 Wet coil: ~0.09 Inches W.C.  
 Downflow: ~0.1 Inches W.C.  
 Reheat coil: ~0.09 Inches W.C.

[ ] Designates Metric Conversions

### 3-6T – HIGH STATIC – SIDEFLOW (208-230V)

Unit Model (Tonnage)	Manufacturer Recommended Airflow Range (Min/Max) CFM	COMPONENT AIRFLOW RESISTANCE		Motor HP [W]	Motor Speed	CFM/ WATTS	External Static Pressure - Inches W.C. [kPa]							
		Pressure Drop MERV 8	Pressure Drop MERV 13				0.8	0.9	1	1.1	1.2	1.3	1.4	1.5
		Resistance - Inches of Water (Min/Max) [kPa]					[.2]	[.22]	[.25]	[.27]	[.3]	[.32]	[.35]	[.37]
RHPCZR036 (3T)	1050/1350	0.075 [.02]/ 0.105 [.03]	0.020 [.00]/ 0.066 [.02]	1 HP [745]	Fan - Tap 1	CFM	1037	974	913	851	795	786	729	676
						WATTS	261	270	279	287	294	298	306	312
				1 HP [745]	Tap 2	CFM	1393	1338	1286	1232	1183	1158	1107	1058
						WATTS	474	485	497	509	520	529	540	549
				1 HP [745]	Tap 3	CFM	1588	1538	1491	1442	1397	1363	1314	1268
						WATTS	591	603	617	630	644	655	668	680
				1 HP [745]	Cooling - Tap 4 *	CFM	1037	974	913	851	795	786	729	676
						WATTS	261	270	279	287	294	298	306	312
				1 HP [745]	High Speed - Tap 5	CFM	1495	1443	1398	1352	1303	1252	1202	1147
						WATTS	493	508	519	531	542	555	563	575
RHPCZR048 (4T)	1400/1800	0.110 [.03]/ 0.150 [.04]	0.074 [.02]/ 0.135 [.03]	1 HP [745]	Fan - Tap 1	CFM	1371	1316	1264	1209	1160	1109	1057	1008
						WATTS	461	472	484	495	506	517	527	537
				1 HP [745]	Tap 2	CFM	1675	1627	1582	1535	1492	1444	1397	1352
						WATTS	643	656	671	684	699	712	725	738
				1 HP [745]	Tap 3	CFM	1740	1693	1650	1605	1563	1516	1470	1426
						WATTS	681	695	711	725	740	754	768	781
				1 HP [745]	Cooling - Tap 4 *	CFM	1360	1305	1252	1198	1148	1097	1045	996
						WATTS	454	466	477	488	499	510	520	530
				1 HP [745]	High Speed - Tap 5	CFM	1800	1762	1721	1676	1641	1587	1546	1512
						WATTS	692	706	719	737	755	768	780	795
RHPCZR060 (5T)	1750/2250	0.145 [.04]/ 0.195 [.05]	0.128 [.03]/ 0.205 [.05]	1 HP [745]	Fan - Tap 1	CFM	1527	1476	1427	1377	1330	1281	1232	1185
						WATTS	554	567	580	592	605	617	629	640
				1 HP [745]	Tap 2	CFM	1523	1471	1423	1372	1326	1277	1227	1180
						WATTS	552	564	577	590	602	614	626	637
				1 HP [745]	Tap 3	CFM	1935	1893	1855	1814	1776	1732	1689	1647
						WATTS	798	813	831	846	864	880	895	910
				1 HP [745]	Cooling - Tap 4 *	CFM	1581	1531	1484	1435	1390	1341	1293	1247
						WATTS	587	599	613	626	640	652	664	676
				1 HP [745]	High Speed - Tap 5	CFM	2151	2115	2082	2046	2013	1972	1932	1893
						WATTS	928	945	964	981	1001	1020	1037	1054
(-)HPCZT072 (6T)	2100/2700	0.180 [.04]/ 0.240 [.06]	0.182 [.04]/ 0.275 [.07]	1.2 HP [895]	Fan/Low Heat - Tap 1	CFM	1237	1182	1137	1076	996	961	906	853
						WATTS	364	373	386	396	405	409	421	431
				1.2 HP [895]	High Heat - Tap 2	CFM	2043	2004	1953	1917	1879	1828	1783	1750
						WATTS	834	850	861	876	891	906	925	938
				1.2 HP [895]	Low Cool - Tap 3	CFM	1149	1082	1030	969	891	837	781	728
						WATTS	338	345	357	365	374	383	393	403
				1.2 HP [895]	High Cool - Tap 4	CFM	2036	1996	1945	1908	1871	1819	1773	1743
						WATTS	820	835	845	860	877	890	910	924
				1.2 HP [895]	High Speed - Tap 5	CFM	2462	2416	2371	2337	2294	2251	2214	2165
						WATTS	1053	1063	1078	1085	1100	1113	1121	1135

NOTES: \* Tap 4 - Factory Cooling Tap  
 Pressure drops across the 3-5T CFM range (1050 - 2250)  
 Pressure drops across the 6T CFM range  
 Wet coil: ~0.09 Inches W.C.  
 Downflow: ~0.1 Inches W.C.  
 Reheat coil: ~0.09 Inches W.C.

[ ] Designates Metric Conversions



### 3-6T – LOW STATIC – SIDEFLOW (460V)

Unit Model (Tonnage)	Manufacturer Recommended Airflow Range (Min/Max) CFM	COMPONENT AIRFLOW RESISTANCE		Motor HP [W]	Motor Speed	CFM/ WATTS	External Static Pressure - Inches W.C. [kPa]							
		Pressure Drop MERV 8	Pressure Drop MERV 13				0.1	0.2	0.3	0.4	0.5	0.6	0.7	0.8
		Resistance - Inches of Water (Min/Max) [kPa]					[.02]	[.05]	[.07]	[.10]	[.12]	[.15]	[.17]	[.20]
RHPCZR036 (3T)	1050/1350	0.075 [.02]/ 0.105 [.03]	0.020 [.00]/ 0.066 [.02]	3/4 HP [559]	Fan - Tap 1	CFM	1110	956	870	792	709	630	549	512
						WATTS	79	78	84	91	98	104	110	111
				3/4 HP [559]	Tap 2	CFM	1255	1120	1040	965	887	813	738	697
						WATTS	145	147	155	163	172	179	186	190
				3/4 HP [559]	Tap 3	CFM	1621	1534	1467	1401	1337	1273	1212	1163
						WATTS	311	321	334	346	357	368	379	388
				3/4 HP [559]	Cooling - Tap 4	CFM	1392	1276	1200	1128	1056	986	916	872
						WATTS	207	212	222	232	241	250	259	264
				3/4 HP [559]	High Speed - Tap 5	CFM	1745	1673	1618	1549	1497	1435	1388	1334
						WATTS	341	357	370	384	396	407	418	430
RHPCZR048 (4T)	1400/1800	0.110 [.03]/ 0.150 [.04]	0.074 [.02]/ 0.135 [.03]	3/4 HP [559]	Fan - Tap 1	CFM	1110	956	870	792	709	630	549	512
						WATTS	79	78	84	91	98	104	110	111
				3/4 HP [559]	Tap 2	CFM	1345	1222	1145	1072	998	926	854	812
						WATTS	186	190	199	208	217	225	234	239
				3/4 HP [559]	Tap 3	CFM	1755	1686	1624	1561	1503	1443	1387	1334
						WATTS	372	386	399	413	425	437	449	461
				3/4 HP [559]	Cooling - Tap 4 *	CFM	1738	1667	1604	1541	1482	1422	1365	1313
						WATTS	365	378	391	404	417	429	441	452
				3/4 HP [559]	High Speed - Tap 5	CFM	2081	2034	1981	1922	1873	1816	1769	1722
						WATTS	560	576	592	609	625	641	657	672
RHPCZR060 (5T)	1750/2250	0.145 [.04]/ 0.195 [.05]	0.128 [.03]/ 0.205 [.05]	1 HP [745]	Fan - Tap 1	CFM	1235	1155	1077	1013	955	882	778	691
						WATTS	150	159	169	177	185	193	204	211
				1 HP [745]	Tap 2	CFM	1453	1382	1311	1246	1188	1131	1064	1002
						WATTS	186	198	209	219	228	236	246	255
				1 HP [745]	Tap 3	CFM	1975	1921	1863	1808	1756	1707	1654	1602
						WATTS	541	557	573	590	605	618	632	644
				1 HP [745]	Cooling - Tap 4 *	CFM	2049	1996	1941	1887	1836	1788	1737	1687
						WATTS	591	608	625	642	657	672	686	699
				1 HP [745]	High Speed - Tap 5	CFM	2408	2367	2318	2267	2226	2177	2139	2089
						WATTS	861	884	900	921	939	957	974	996
(-)HPCZT072 (6T)	2100/2700	0.180 [.04]/ 0.240 [.06]	0.182 [.04]/ 0.275 [.07]	1.2 HP [895]	Fan/Low Heat - Tap 1	CFM	1384	1319	1249	1188	1127	1066	1006	947
						WATTS	192	204	215	225	240	245	255	265
				1.2 HP [895]	High Heat - Tap 2	CFM	1863	1821	1765	1717	1650	1617	1571	1526
						WATTS	413	428	442	459	474	488	503	518
				1.2 HP [895]	Low Cool - Tap 3	CFM	1546	1488	1427	1372	1316	1261	1203	1149
						WATTS	258	270	282	298	310	318	330	338
				1.2 HP [895]	High Cool - Tap 4	CFM	2331	2290	2245	2204	2159	2118	2072	2036
						WATTS	700	718	730	745	760	782	797	820
				1.2 HP [895]	High Speed - Tap 5	CFM	2363	2330	2280	2237	2198	2164	2110	2071
						WATTS	771	792	808	824	843	860	875	890

NOTES: 1. For 575V units, add 30W (transformer wattage) to the watt values mentioned in the table.

2. Factory tap settings are marked with an asterisk \*.

3. Pressure drops across the 3-5T CFM range (1050 - 2250)

Pressure drops across the 6T CFM range

Wet coil: ~0.09 Inches W.C.

Downflow: ~0.1 Inches W.C.

Reheat coil: ~0.09 Inches W.C.

[ ] Designates Metric Conversions



### 3-6T – HIGH STATIC – SIDEFLOW (460V)

Unit Model (Tonnage)	Manufacturer Recommended Airflow Range (Min/Max) CFM	COMPONENT AIRFLOW RESISTANCE		Motor HP [W]	Motor Speed	CFM/ WATTS	External Static Pressure - Inches W.C. [kPa]							
		Pressure Drop MERV 8	Pressure Drop MERV 13				0.8	0.9	1	1.1	1.2	1.3	1.4	1.5
		Resistance - Inches of Water (Min/Max) [kPa]					[.2]	[.22]	[.25]	[.27]	[.3]	[.32]	[.35]	[.37]
RHPCZR036 (3T)	1050/1350	0.075 [.02]/ 0.105 [.03]	0.020 [.00]/ 0.066 [.02]	1 HP [745]	Fan - Tap 1	CFM	958	895	828	768	722	669	684	653
						WATTS	226	235	247	259	280	304	337	371
				1 HP [745]	Tap 2	CFM	958	895	828	768	722	669	684	653
						WATTS	226	235	247	259	280	304	337	371
				1 HP [745]	Tap 3	CFM	1591	1540	1486	1434	1375	1311	1263	1179
						WATTS	637	649	659	668	670	667	664	649
				1 HP [745]	Cooling - Tap 4 *	CFM	1064	1002	938	879	831	776	780	741
						WATTS	295	304	315	327	345	365	391	417
				1 HP [745]	High Speed - Tap 5	CFM	1526	1481	1440	1392	1336	1285	1231	1175
						WATTS	531	540	552	563	578	588	598	610
RHPCZR048 (4T)	1400/1800	0.110 [.03]/ 0.150 [.04]	0.074 [.02]/ 0.135 [.03]	1 HP [745]	Fan - Tap 1	CFM	1061	1000	935	877	828	774	778	739
						WATTS	293	302	314	325	344	363	390	416
				1 HP [745]	Tap 2	CFM	1438	1384	1327	1272	1217	1156	1123	1052
						WATTS	537	549	559	569	576	579	585	581
				1 HP [745]	Tap 3	CFM	1629	1579	1526	1474	1415	1350	1298	1211
						WATTS	662	674	684	693	694	689	684	666
				1 HP [745]	Cooling - Tap 4 *	CFM	1434	1380	1323	1269	1213	1152	1120	1049
						WATTS	535	546	557	567	574	577	583	580
				1 HP [745]	High Speed - Tap 5	CFM	1795	1751	1710	1668	1629	1581	1538	1490
						WATTS	721	734	745	758	770	784	795	811
RHPCZR060 (5T)	1750/2250	0.145 [.04]/ 0.195 [.05]	0.128 [.03]/ 0.205 [.05]	1 HP [745]	Fan - Tap 1	CFM	1063	1000	909	849	796	743	695	644
						WATTS	311	319	331	341	355	365	375	384
				1 HP [745]	Tap 2	CFM	1063	1000	909	849	796	743	695	644
						WATTS	311	319	331	341	355	365	375	384
				1 HP [745]	Tap 3	CFM	1444	1390	1335	1279	1220	1161	1090	1035
						WATTS	468	487	488	499	505	514	513	521
				1 HP [745]	Cooling - Tap 4 *	CFM	1826	1795	1754	1714	1674	1636	1590	1540
						WATTS	681	700	720	738	757	774	787	799
				1 HP [745]	High Speed - Tap 5	CFM	2127	2076	2045	2000	1966	1930	1894	1871
						WATTS	906	924	941	958	977	1008	1021	1049
(-)HPCZT072 (6T)	2100/2700	0.180 [.04]/ 0.240 [.06]	0.182 [.04]/ 0.275 [.07]	1.2 HP [895]	Fan/Low Heat - Tap 1	CFM	1237	1182	1137	1076	996	961	906	853
						WATTS	364	373	386	396	405	409	421	431
				1.2 HP [895]	High Heat - Tap 2	CFM	2043	2004	1953	1917	1879	1828	1783	1750
						WATTS	834	850	861	876	891	906	925	938
				1.2 HP [895]	Low Cool - Tap 3	CFM	1149	1082	1030	969	891	837	781	728
						WATTS	338	345	357	365	374	383	393	403
				1.2 HP [895]	High Cool - Tap 4	CFM	2036	1996	1945	1908	1871	1819	1773	1743
						WATTS	820	835	845	860	877	890	910	924
				1.2 HP [895]	High Speed - Tap 5	CFM	2462	2416	2371	2337	2294	2251	2214	2165
						WATTS	1053	1063	1078	1085	1100	1113	1121	1135

NOTES: 1. For 575V units, add 30W (transformer wattage) to the watt values mentioned in the table.

2. Factory tap settings are marked with an asterisk \*.

3. Pressure drops across the 3-5T CFM range (1050 - 2250)

Pressure drops across the 6T CFM range

Wet coil: ~0.09 Inches W.C.

Downflow: ~0.1 Inches W.C.

Reheat coil: ~0.09 Inches W.C.

[ ] Designates Metric Conversions

**ELECTRICAL DATA—RHPCZ(-) SERIES**

	<b>036ACT</b>	<b>036ACU</b>	<b>036ADT</b>	<b>036ADU</b>	<b>036AJT</b>	<b>036AJU</b>	<b>048ACT</b>	<b>048ACU</b>	<b>048ADT</b>
<b>Unit Information</b>	Unit Operating Voltage Range	187-253	418-506	418-506	187-253	187-253	187-253	187-253	418-506
	Volts	208/230	208/230	460	208/230	208/230	208/230	208/230	460
	Phase	3	3	3	1	1	3	3	3
	Hz	60	60	60	60	60	60	60	60
	Minimum Circuit Ampacity	21	26	12	11	31	36	26	32
	Minimum Overcurrent Protection Device Size	25	30	15	15	35	40	30	35
	Maximum Overcurrent Protection Device Size	30	35	15	15	45	50	35	40
	No.	1	1	1	1	1	1	1	1
	Volts	208/230	208/230	480	480	208/230	208/230	208/230	208/230
	Phase	3	3	3	3	1	1	3	3
<b>Compressor Motor</b>	RPM	3450	3450	3450	3450	3450	3450	3450	3450
	HP, Compressor <sup>1</sup>	2 1/2	2 1/2	2 1/2	2 1/2	3	3 1/2	3 1/2	3 1/2
	Amps (RLA), Comp. <sup>1</sup>	11.6	11.6	6.4	6.4	22.6	22.6	15.3	15.3
	Amps (LRA), Comp. <sup>1</sup>	73	73	38	38	79	79	83.1	83.1
	No.	1	1	1	1	2	2	1	1
	Volts	208/230	208/230	480	480	208/230	208/230	208/230	208/230
<b>Condenser Motor</b>	Phase	1	1	1	1	1	1	1	1
	HP	1/5	1/5	1/5	1/5	1/5	1/5	1/2	1/2
	Amps (FLA, each)	1.2	1.2	0.8	0.8	1.2	1.2	2.5	2.5
	Amps (LRA, each)	2.3	2.3	1.4	1.4	2.3	2.3	5.6	5.6
	No.	1	1	1	1	1	1	1	1
	Volts	208/230	208/230	460	460	208/230	208/230	208/230	208/230
<b>Evaporator Fan</b>	Phase	1	1	1	1	1	1	1	1
	HP	3/4	1 1/2	3/4	1 1/2	3/4	1 1/2	1 1/2	3/4
	Amps (FLA, each)	6	6	3.2	3.2	6	6	6	3.2



**ELECTRICAL DATA—RHPCZ(-) SERIES**

	<b>048ADU</b>	<b>048AJT</b>	<b>048AJU</b>	<b>060ACT</b>	<b>060ACU</b>	<b>060ADT</b>	<b>060ADU</b>	<b>060AJT</b>	<b>060AJU</b>
Unit Operating Voltage Range	418-506	187-253	187-253	187-253	187-253	418-506	418-506	187-253	187-253
Volts	460	208/230	208/230	208/230	208/230	460	460	208/230	208/230
Phase	3	1	1	3	3	3	3	1	1
Hz	60	60	60	60	60	60	60	60	60
Minimum Circuit Ampacity	12	36	42	34	34	16	16	49	49
Minimum Overcurrent Protection Device Size	15	45	50	40	40	20	20	60	60
Maximum Overcurrent Protection Device Size	15	50	60	45	45	20	20	70	70
No.	1	1	1	1	1	1	1	1	1
Volts	460	208/230	208/230	208/230	208/230	460	460	208/230	208/230
Phase	3	1	1	3	3	3	3	1	1
RPM	3450	3450	3450	3450	3450	3450	3450	3450	3450
HP, Compressor <sup>1</sup>	3 1/2	3 1/2	3 1/2	4	4	4	4	4	4
Amps (RLA), Comp. <sup>1</sup>	6.9	24.3	24.3	17.8	17.8	8.6	8.6	29.4	29.4
Amps (LRA), Comp. <sup>1</sup>	41	117	117	110	110	52	52	134	134
No.	1	1	1	1	1	1	1	1	1
Volts	460	208/230	208/230	208/230	208/230	460	460	208/230	208/230
Phase	1	1	1	1	1	1	1	1	1
HP	1/2	1/2	1/2	1/2	1/2	1/2	1/2	1/2	1/2
Amps (FLA, each)	1.5	2.5	2.5	2.5	2.5	1.5	1.5	2.5	2.5
Amps (LRA, each)	3.1	5.6	5.6	5.6	5.6	3.1	3.1	5.6	5.6
No.	1	1	1	1	1	1	1	1	1
Volts	460	208/230	208/230	208/230	208/230	460	460	208/230	208/230
Phase	1	1	1	1	1	1	1	1	1
HP	1 1/2	3/4	1 1/2	1	1 1/2	1	1 1/2	1	1 1/2
Amps (FLA, each)	3.2	6	6	11.5	11.5	4	4	11.5	11.5

**ELECTRICAL DATA—RHPCZ(-) SERIES**

	072ACT	072ACU	072ADT	072ADU
<b>Unit Information</b>	Unit Operating Voltage Range	187-253	187-253	418-506
	Volts	208/230	208/230	460
	Phase	3	3	3
	Hz	60	60	60
	Minimum Circuit Ampacity	36	36	18
	Minimum Overcurrent Protection Device Size	45	45	25
	Maximum Overcurrent Protection Device Size	50	50	25
	No.	1	1	1
	Volts	230	230	460
	Phase	3	3	3
<b>Compressor Motor</b>	RPM	3450	3450	3450
	HP, Compressor <sup>1</sup>	5	5	5
	Amps (RLA), Comp. <sup>1</sup>	17.6	17.6	8.5
	Amps (LRA), Comp. <sup>1</sup>	136	136	66.1
	No.	1	1	1
	Volts	230	230	460
<b>Condenser Motor</b>	Phase	1	1	1
	HP	1	1	1
	Amps (FLA, each)	7.4	7.4	3.6
	Amps (LRA, each)			
<b>Evaporator Fan</b>	No.	1	1	1
	Volts	230	230	460
	Phase	1	1	1
	HP	1 1/5	1 1/5	1 1/5
Amps (FLA, each)	6.6	6.6	3.7	

208/230V, Three Phase, 60 Hz, Auxiliary Electric Heater Kit Characteristics and Application									
Single Power Supply for Both Unit and Heater Kit					Separate Power Supply for Both Unit and Heater Kit				
Unit Model Number RHPCZR (036-060) RHPCZT (072)	Heater Kit			Air Conditioner		Heater Kit		Air Conditioner	
	Model No. RXJJ-	Rated Heater kW @ 208/240V	FLA	Unit Min. Ckt. Ampacity	Max Fuse or Ckt. Bkr. Size (Ckt Bkr Must Be HACR Type for USA)	Min. Ckt. Ampacity	Max Fuse or Ckt. Bkr. Size (Ckt Bkr Must Be HACR Type for USA)	Min. Ckt. Ampacity	Max Fuse or Ckt. Bkr. Size (Ckt Bkr Must Be HACR Type for USA)
036ACT	NONE	—	—	20/20	30/30	—	—	20/20	30/30
	DC10CP	7.5/10.0	20.9/24.1	47/51	50/60	27/31	30/35	20/20	30/30
	DC15CP	11.3/15.0	31.4/36.2	60/66	70/70	40/46	40/50	20/20	30/30
	DC20CP	15.0/20.0	41.7/48.1	73/81	80/90	53/61	60/70	20/20	30/30
036ACU	NONE	—	—	26/26	35/35	—	—	26/26	35/35
	DC10CP	7.5/10.0	20.9/24.1	52/56	60/60	27/31	30/35	26/26	35/35
	DC15CP	11.3/15.0	31.4/36.2	66/72	70/80	40/46	40/50	26/26	35/35
	DC20CP	15.0/20.0	41.7/48.1	78/86	90/90	53/61	60/70	26/26	35/35
048ACT	NONE	—	—	26/26	35/35	—	—	26/26	35/35
	DC10CP	7.5/10.0	20.9/24.1	52/56	60/60	27/31	30/35	26/26	35/35
	DC15CP	11.3/15.0	31.4/36.2	65/71	70/80	40/46	40/50	26/26	35/35
	DC20CP	15.0/20.0	41.7/48.1	78/86	80/90	53/61	60/70	26/26	35/35
048ACU	NONE	—	—	31/31	40/40	—	—	31/31	40/40
	DC10CP	7.5/10.0	20.9/24.1	58/62	70/70	27/31	30/35	31/31	40/40
	DC15CP	11.3/15.0	31.4/36.2	71/77	80/80	40/46	40/50	31/31	40/40
	DC20CP	15.0/20.0	41.7/48.1	84/92	90/100	53/61	60/70	31/31	40/40
060ACT	NONE	—	—	33/33	45/45	—	—	33/33	45/45
	DC10CP	7.5/10.0	20.9/24.1	60/64	70/70	27/31	30/35	33/33	45/45
	DC15CP	11.3/15.0	31.4/36.2	73/79	80/90	40/46	40/50	33/33	45/45
	DC20CP	15.0/20.0	41.7/48.1	86/94	90/100	53/61	60/70	33/33	45/45
060ACU	NONE	—	—	37/37	50/50	—	—	37/37	50/50
	DC10CP	7.5/10.0	20.9/24.1	63/67	70/80	27/31	30/35	37/37	50/50
	DC15CP	11.3/15.0	31.4/36.2	77/83	90/90	40/46	40/50	37/37	50/50
	DC20CP	15.0/20.0	41.7/48.1	89/97	100/110	53/61	60/70	37/37	50/50
072ACT	NONE	—	—	36/36	50/50	—	—	36/36	50/50
	DC10CP	11.3/15.0	31.4/36.2	76/82	80/90	40/46	40/50	36/36	50/50
	DC15CP	15.0/20.0	41.7/48.1	89/97	100/100	53/61	60/70	36/36	50/50
	DC24CP	18.0/24.0	50.0/57.7	99/109	110/125	63/73	70/80	36/36	50/50
072ACU	NONE	—	—	36/36	50/50	—	—	36/36	50/50
	DC15CP	11.3/15.0	31.4/36.2	76/82	80/90	40/46	40/50	36/36	50/50
	DC20CP	15.0/20.0	41.7/48.1	89/97	100/100	53/61	60/70	36/36	50/50
	DC24CP	18.0/24.0	50.0/57.7	99/109	110/125	63/73	70/80	36/36	50/50

**208/230V, Single Phase, 60 Hz, Auxiliary Electric Heater Kit Characteristics and Application**

<b>208/230V, Single Phase, 60 Hz, Auxiliary Electric Heater Kit Characteristics and Application</b>									
<b>Single Power Supply for Both Unit and Heater Kit</b>					<b>Separate Power Supply for Both Unit and Heater Kit</b>				
<b>Unit Model Number RHPCZR (036-060) RHPCZT (072)</b>	<b>Heater Kit</b>			<b>Air Conditioner</b>		<b>Heater Kit</b>		<b>Air Conditioner</b>	
	<b>Model No. RXJJ-</b>	<b>Rated Heater kW @ 208/240V</b>	<b>FLA</b>	<b>Unit Min. Ckt. Ampacity</b>	<b>Max Fuse or Ckt. Bkr. Size (Ckt Bkr Must Be HACR Type for USA)</b>	<b>Min. Ckt. Ampacity</b>	<b>Max Fuse or Ckt. Bkr. Size (Ckt Bkr Must Be HACR Type for USA)</b>	<b>Min. Ckt. Ampacity</b>	<b>Max Fuse or Ckt. Bkr. Size (Ckt Bkr Must Be HACR Type for USA)</b>
036AJT	NONE	—	—	29/29	40/40	—	—	29/29	40/40
	DC10JT	7.5/10.0	36.2/41.7	74/81	80/90	46/53	50/60	29/29	40/40
	DC15JT	11.3/15.0	54.3/62.7	96/107	100/110	68/79	70/80	29/29	40/40
	DC20JT	15.0/20.0	72.2/83.3	119/133	125/150	91/105	100/110	29/29	40/40
036AJU	NONE	—	—	34/34	50/50	—	—	34/34	50/50
	DC10JT	7.5/10.0	36.2/41.7	79/86	90/90	46/53	50/60	34/34	50/50
	DC15JT	11.3/15.0	54.3/62.7	102/112	110/125	68/79	70/80	34/34	50/50
	DC20JT	15.0/20.0	72.2/83.3	124/138	150/150	91/105	100/110	34/34	50/50
048AJT	NONE	—	—	36/36	50/50	—	—	36/36	50/50
	DC10JT	7.5/10.0	36.2/41.7	81/88	90/90	46/53	50/60	36/36	50/50
	DC15JT	11.3/15.0	54.3/62.7	104/114	110/125	68/79	70/80	36/36	50/50
	DC20JT	15.0/20.0	72.2/83.3	126/140	150/150	91/105	100/110	36/36	50/50
048AJU	NONE	—	—	42/42	60/60	—	—	42/42	60/60
	DC10JT	7.5/10.0	36.2/41.7	87/94	90/100	46/53	50/60	42/42	60/60
	DC15JT	11.3/15.0	36.2/41.7	109/120	125/125	68/79	70/80	42/42	60/60
	DC20JT	15.0/20.0	72.2/83.3	132/146	150/150	91/105	100/110	42/42	60/60
060AJT	NONE	—	—	46/46	70/70	—	—	46/46	70/70
	DC10JT	7.5/10.0	36.2/41.7	92/99	100/110	46/53	50/60	46/46	70/70
	DC15JT	11.3/15.0	54.3/62.7	114/125	125/150	68/79	70/80	46/46	70/70
	DC20JT	15.0/20.0	72.2/83.3	137/151	150/175	91/105	100/110	46/46	70/70
060AJU	NONE	—	—	50/50	70/70	—	—	50/50	70/70
	DC10JT	7.5/10.0	36.2/41.7	96/102	110/110	46/53	50/60	50/50	70/70
	DC15JT	11.3/15.0	54.3/62.7	118/129	125/150	68/79	70/80	50/50	70/70
	DC20JT	15.0/20.0	72.2/83.3	141/154	150/175	91/105	100/110	50/50	70/70

@ 460V Three Phase, 60 Hz, Auxiliary Electric Heater Kit Characteristics and Application									
Single Power Supply for Both Unit and Heater Kit					Separate Power Supply for Both Unit and Heater Kit				
Unit Model Number RHPCZR (036-060) RHPCZT (072)	Heater Kit			Air Conditioner		Heater Kit		Air Conditioner	
	Model No. RXJJ-	Rated Heater kW @ 208/240V	FLA	Unit Min. Ckt. Ampacity	Max Fuse or Ckt. Bkr. Size (Ckt Bkr Must Be HACR Type for USA)	Min. Ckt. Ampacity	Max Fuse or Ckt. Bkr. Size (Ckt Bkr Must Be HACR Type for USA)	Min. Ckt. Ampacity	Max Fuse or Ckt. Bkr. Size (Ckt Bkr Must Be HACR Type for USA)
036ADT	NONE	—	—	12	15	—	—	12	15
	DC10DNV	10.0	12.0	27	30	15	15	12	15
	DC15DNV	15.0	18.1	34	35	23	25	12	15
	DC20DNV	20.0	24.1	42	45	31	35	12	15
036ADU	NONE	—	—	11	15	—	—	11	15
	DC10DNV	10.0	12.0	26	30	15	15	11	15
	DC15DNV	15.0	18.1	33	35	23	25	11	15
	DC20DNV	20.0	24.1	41	45	31	35	11	15
048ADT	NONE	—	—	13	15	—	—	13	15
	DC10DNV	10.0	12.0	28	30	15	15	13	15
	DC15DNV	15.0	18.1	36	40	23	25	13	15
	DC20DNV	20.0	24.1	43	45	31	35	13	15
048ADU	NONE	—	—	12	15	—	—	12	15
	DC10DNV	10.0	12.0	27	30	15	15	12	15
	DC15DNV	15.0	18.1	34	35	23	25	12	15
	DC20DNV	20.0	24.1	42	45	31	35	12	15
060ADT	NONE	—	—	17	20	—	—	17	20
	DC10DNV	10.0	12.0	32	35	15	15	17	20
	DC15DNV	15.0	18.1	39	45	23	25	17	20
	DC20DNV	20.0	24.1	47	50	31	35	17	20
060ADU	NONE	—	—	16	20	—	—	16	20
	DC10DNV	10.0	12.0	31	35	15	15	16	20
	DC15DNV	15.0	18.1	39	45	23	25	16	20
	DC20DNV	20.0	24.1	47	50	31	35	16	20
072ADT	NONE	—	—	18	25	—	—	18	25
	DC15DNV	15.0	18.1	41	45	23	25	18	25
	DC20DNV	20.0	24.1	49	50	31	35	18	25
	DC24DNV	24.0	28.9	55	60	37	40	18	25
072ADU	NONE	—	—	18	25	—	—	18	25
	DC15DNV	15.0	18.1	41	45	23	25	18	25
	DC20DNV	20.0	24.1	49	50	31	35	18	25
	DC24DNV	24.0	28.9	55	60	37	40	18	25

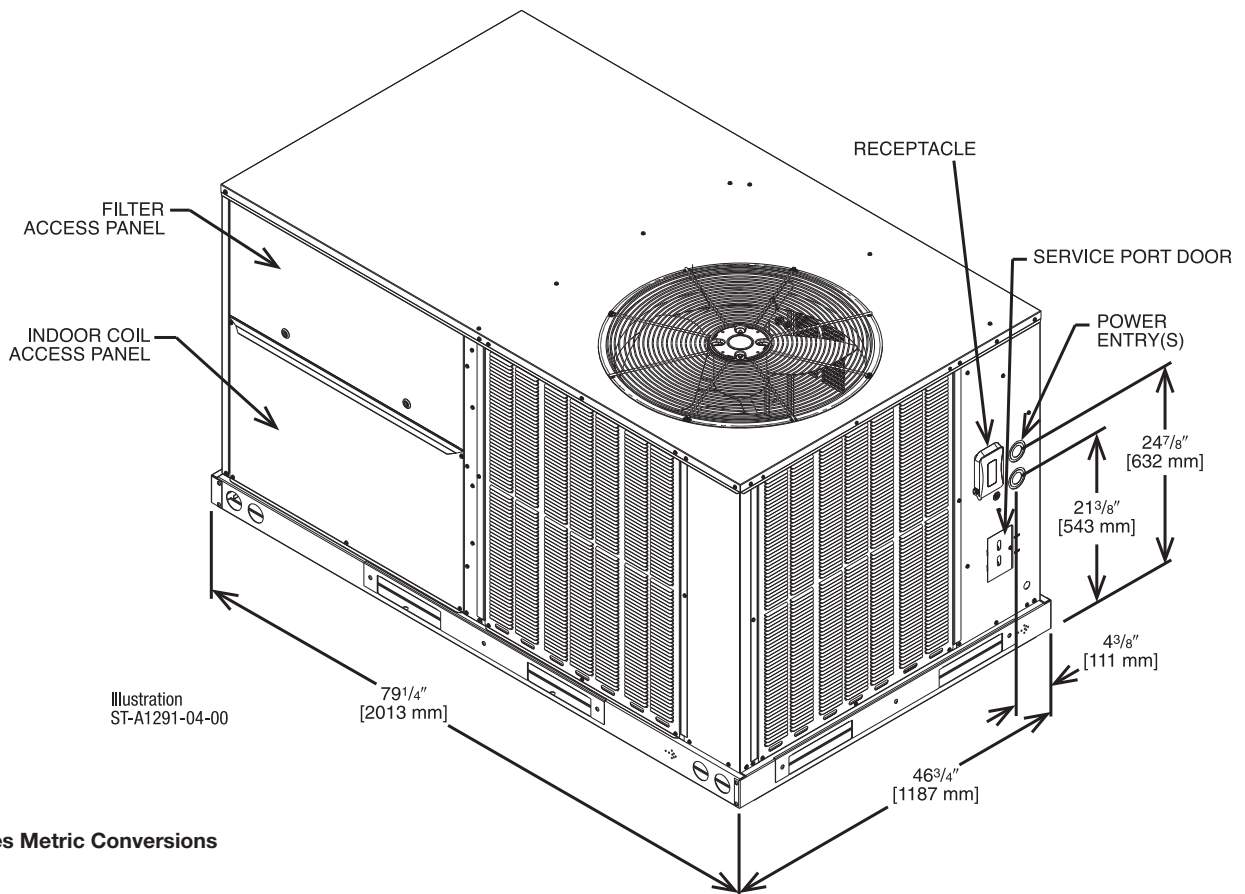
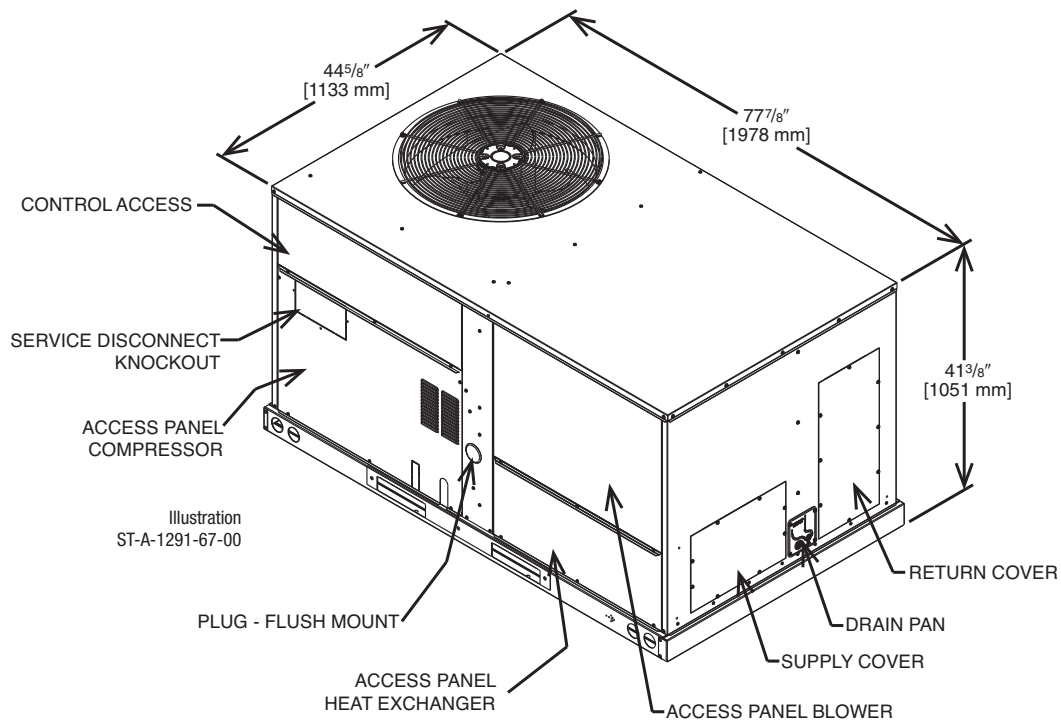

[ ] Designates Metric Conversions

**SUPPLY AND RETURN DIMENSIONS FOR  
HORIZONTAL APPLICATIONS  
(SIDE VIEW)**

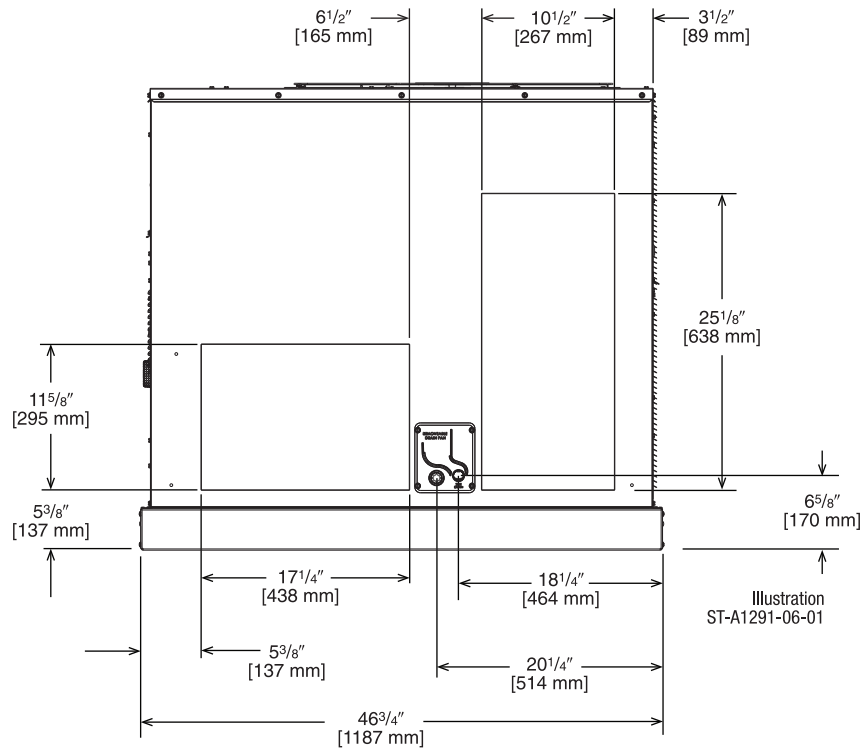

**SUPPLY AND RETURN DIMENSIONS FOR  
DOWNFLOW APPLICATIONS  
(BOTTOM VIEW)**

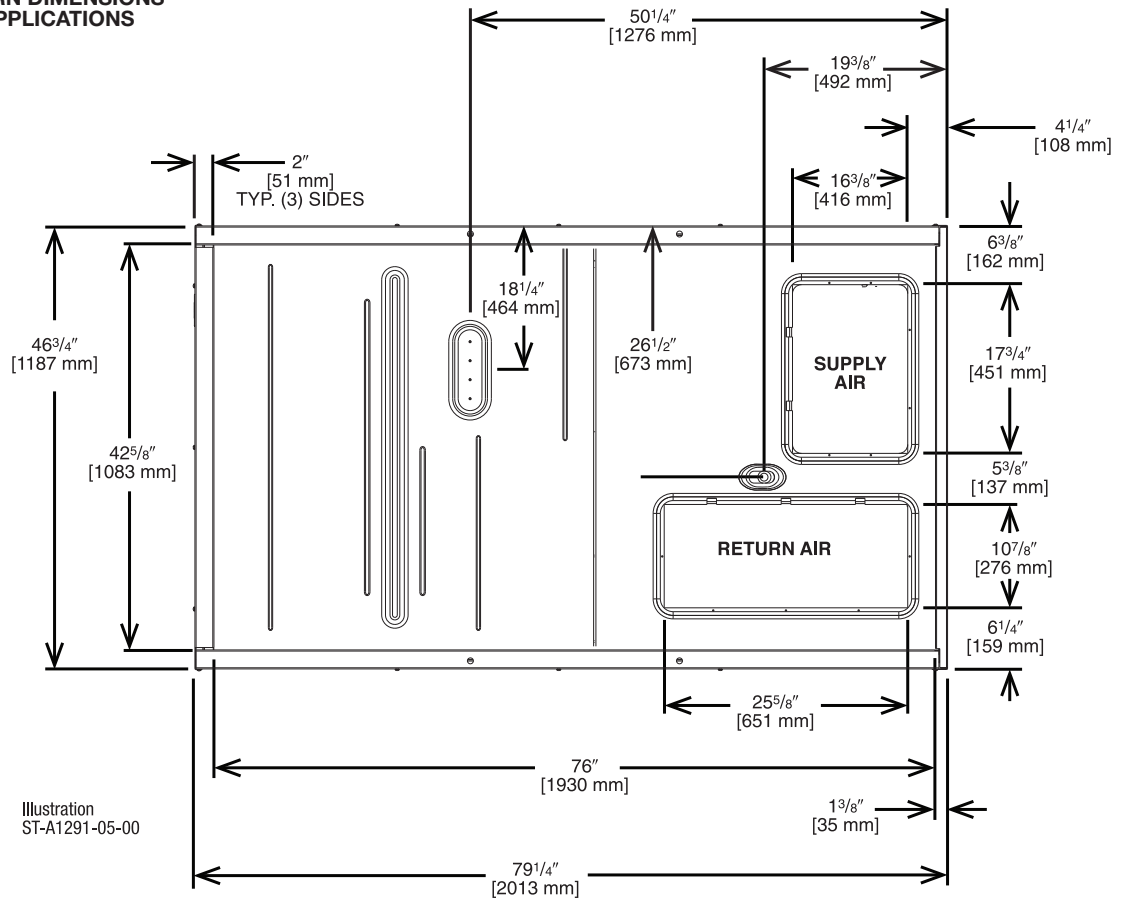

[ ] Designates Metric Conversions

# WEIGHTS

Capacity Tons [kW]	Corner Weights by Percentage			
	A	B	C	D
3.0-6.0 [10.6-21.1]	18%	40%	19%	23%

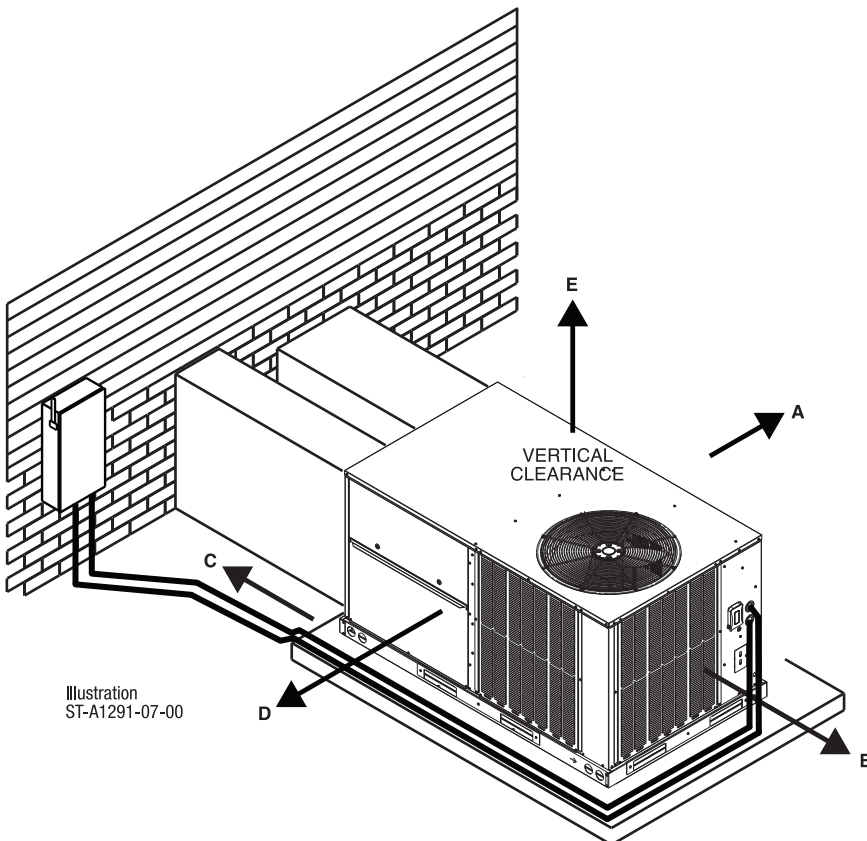
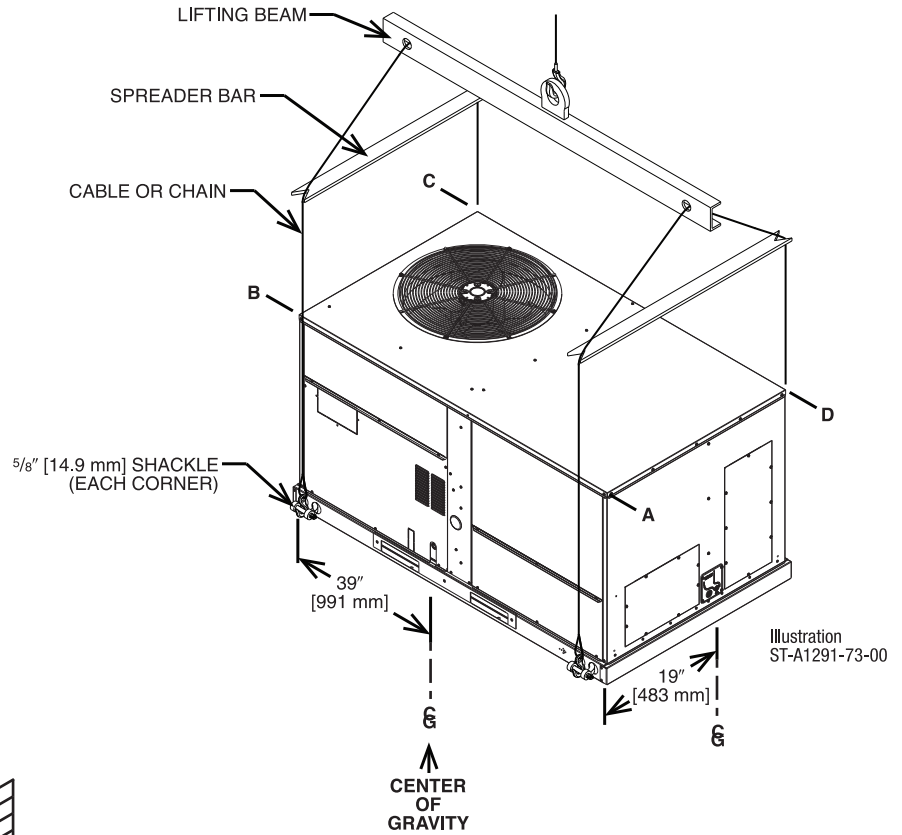

### CLEARANCES

THE FOLLOWING MINIMUM CLEARANCES MUST BE OBSERVED FOR PROPER UNIT PERFORMANCE AND SERVICEABILITY.

RECOMMENDED CLEARANCE In. [mm]	LOCATION
48 [1219]	A - FRONT
24 [609]	B - CONDENSER END
48 [1219] ①	C - DUCT END
24 [609] ②	*D - FILTER SIDE
60 [1524]	E - ABOVE

- ① 18" [457 mm] MINIMUM IF DRAINPAN WILL NOT BE REMOVED.
- ② 48" [1219 mm] MINIMUM IF ECONOMIZER IS INSTALLED.

[ ] Designates Metric Conversions





## FIELD-INSTALLED ACCESSORY EQUIPMENT

Accessory	Model Number	Shipping Weight Lbs. [kg]	Installed Weight Lbs. [kg]	Factory Installation Available?
Economizer w/Single Enthalpy (Downflow/Vertical)	RXRD-01MCDAM3	100 [45.4]	66 [29.9]	Yes
Economizer w/Single Enthalpy (Horizontal)	RXRD-01MCHAM3	72 [32.7]	69 [31.3]	No
Economizer-w/Single Enthalpy (Downflow/Vertical) DDC	RXRD-01MCDBM3	100 [45.4]	66 [29.9]	Yes
Economizer w/Single Enthalpy (Horizontal) DDC	RXRD-01MCHBM3	72 [32.7]	69 [31.3]	No
Dual Enthalpy Kit	RXRX-BV01	1 [0.5]	1 [0.5]	No
Dual Enthalpy Kit DDC	RXRX-BV02	1 [0.5]	1 [0.5]	No
Power Exhaust (230V) Vertical	RXRX-CCF02C	24 [10.9]	21 [9.5]	No
Power Exhaust (460V) Vertical	RXRX-CCF02D	20 [9.1]	17 [7.7]	No
Power Exhaust (230V) Horizontal	RXRX-CCF03C	42 [19.1]	39 [17.7]	No
Power Exhaust (460V) Horizontal	RXRX-CCF03D	42 [19.1]	39 [17.7]	No
Manual Fresh Air Damper	RXRF-ACA1	22 [10.0]	18 [8.2]	No
Motorized Fresh Air Damper	RXRF-ACB1	53 [24.0]	43 [19.5]	No
Motorized Fresh Air Damper (DDC)	RXRF-ACC1	53 [24.0]	43 [19.5]	No
Roofcurb, 14"	RXKG-DCC14	94 [42.6]	90 [40.8]	No
Roofcurb, 24"	RXKG-DCC24	124 [56.2]	120 [54.4]	No
Roofcurb Adapter	RXRX-DCCAE	159 [72.1]	145 [65.8]	No
Concentric Diffuser 3-4 Ton Flush	RXRN-AEF1800	30 [13.6]	25 [11.3]	No
Concentric Diffuser 5-6 Ton Flush	RXRN-AEF2000	30 [13.6]	25 [11.3]	No
Concentric Diffuser 3-4 Ton Drop	RXRN-AED1800	35 [15.9]	30 [13.6]	No
Concentric Diffuser 5-6 Ton Drop	RXRN-AED2000	35 [15.9]	30 [13.6]	No
Concentric Adapter 3-4 Ton Drop	RXMC-DC01	35 [15.9]	30 [13.6]	No
Concentric Adapter 5-6 Ton Drop	RXMC-DC02	40 [18.2]	35 [15.9]	No
Outdoor Coil Louver Kit	RXRX-ADD04C	30 [13.6]	25 [11.3]	Yes
Nonpowered Convenience Outlet	RXRX-BN01	2 [1.0]	1.5 [0.7]	Yes
Unfused Service Disconnect	RXRX-BP01	10 [4.5]	9 [4.1]	Yes
Comfort Alert (1 Phase) DDC	RXRX-AZ03	3 [1.5]	2 [0.9]	Yes
Comfort Alert (1 Phase) Non-DDC	RXRX-AZ04	3 [1.5]	2 [0.9]	Yes
Comfort Alert (3 Phase) DDC	RXRX-AZ01	3 [1.5]	2 [0.9]	Yes
Comfort Alert (3 Phase) Non-DDC	RXRX-AZ02	3 [1.5]	2 [0.9]	Yes
Carbon Dioxide Sensor (Wall Mount)	RXRX-AR02	1 [0.5]	1 [0.5]	No
BACnet Communication Card	RXRX-AY01	1 [0.5]	1 [0.5]	No
LonWorks Communication Card	RXRX-AY02	1 [0.5]	1 [0.5]	No
Room Humidity Sensor	RHC-ZNS4	1 [0.5]	1 [0.5]	No
Room Temperature and Relative Humidity Sensor	RHC-ZNS5	1 [0.5]	1 [0.5]	No
Low-Ambient Control Kit	RXRZ-A04	4 [1.8]	3 [1.4]	Yes
Freeze Stat Kit	RXRX-AM05	2 [1.0]	1.5 [0.7]	Yes
Return Smoke Detector (Field kit)	RXRX-BS01	7 [3.2]	6 [2.7]	No
Return/ Supply Smoke Detector (Field kit)	RXRX-BS02	5 [2.3]	4 [1.8]	No
LP Kit (-)GEC 75K, 120K)	RXGJ-FP40	2 [1.0]	1 [0.5]	No
LP Kit (-)GEC 100K)	RXGJ-FP41	2 [1.0]	1 [0.5]	No
Electric Heater Kits*	RXJJ-DC10JT	10 [4.5]	8 [3.6]	Yes
	RXJJ-DC15JT	13 [5.9]	11 [5.0]	Yes
	RXJJ-DC20JT	14 [6.4]	12 [5.4]	Yes
	RXJJ-DC10CP	10 [4.5]	8 [3.6]	Yes
	RXJJ-DC15CP	13 [5.9]	11 [5.0]	Yes
	RXJJ-DC20CP	14 [6.4]	12 [5.4]	Yes
	RXJJ-DC24CP	14 [6.4]	12 [5.4]	Yes
	RXJJ-DC10DNV	10 [4.5]	8 [3.6]	Yes
	RXJJ-DC15DNV	13 [5.9]	11 [5.0]	Yes
	RXJJ-DC20DNV	14 [6.4]	12 [5.4]	Yes
	RXJJ-DC24DNV	14 [6.4]	12 [5.4]	Yes
Single Point Wiring Kits	RXJX-AJ0601 (Single Phase)	20 [9.1]	17 [7.7]	No
	RXJX-AZ0601 (Three Phase)	23 [10.4]	20 [9.1]	No
MERV 8 Filter	RXMF-M08A21616	2 [.90]	1 [.45]	No
MERV 13 Filter	RXMF-M13A21616	2 [.90]	1 [.45]	No

\*10kW options not available on 6 Ton models.

[ ] Designates Metric Conversions



## FLUSH MOUNT ROOM TEMPERATURE SENSORS FOR NETWORKED DDC APPLICATIONS



### ROOM TEMPERATURE SENSOR with TIMED OVERRIDE BUTTON

**RHC-ZNS1**

10kΩ room temperature sensor transmits room temperature to DDC system. Timed override button allows tenant to change from unoccupied temperature setpoint to occupied temperature setpoint for a preset time.



### ROOM TEMPERATURE SENSOR with TIMED OVERRIDE BUTTON and STATUS INDICATOR

**RHC-ZNS2**

10kΩ room temperature sensor transmits room temperature to DDC system. Timed override button allows tenant to change from unoccupied temperature setpoint to occupied temperature setpoint for a preset time. Status Indicator Light transmits ALARM flash code to occupied space.



### ROOM TEMPERATURE SENSOR with SETPOINT ADJUSTMENT and TIMED OVERRIDE BUTTON

**RHC-ZNS3**

10kΩ room temperature sensor with setpoint adjustment transmits room temperature to DDC system along with desired occupied room temperature setpoint. Timed override button allows tenant to change from unoccupied temperature setpoint to occupied temperature setpoint for a preset time.

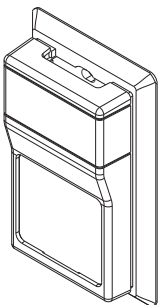

### ROOM HUMIDITY SENSOR

**RHC-ZNS4**

Transmits room relative humidity to DDC System.

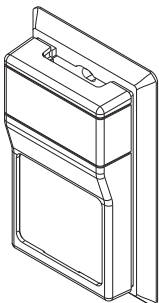

### ROOM TEMPERATURE AND RELATIVE HUMIDITY SENSOR

**RHC-ZNS5**

Transmits room temperature and relative humidity to DDC System.

## COMMUNICATION CARDS



### **BACnet® COMMUNICATION CARD    RXRX-AY01**

The field installed BACnet® Communication Card allows the RTU-C unit controller to communicate with a third party building management system that supports the BACnet Application Specific Controller device profile. The BACnet® Communication Module plugs onto the unit RTU-C controller and allows communication between the RTU-C and the BACnet MSTP network.



### **LonWorks® COMMUNICATION CARD    RXRX-AY02**

The field installed LonWorks® Communication Card allows the RTU-C unit controller to communicate with a third party building management system that supports the LonMark Space Comfort Controller (SCC) functional profile or LonMark Discharge Air Controller (DAC) functional profile. The LonMark Communication Module plugs onto the RTU-C controller and allows communication between the RTU-C and a LonWorks Network.

## ELECTRIC HEAT AND SINGLE POINT WIRING

The field or factory electric heater kits are available in 10, 15 and 20 kW heating inputs, and for both single and 3-phase applications. The single point wiring kit is only available as a field installation accessory for units using electric heat, and also available for both single and 3-phase applications.

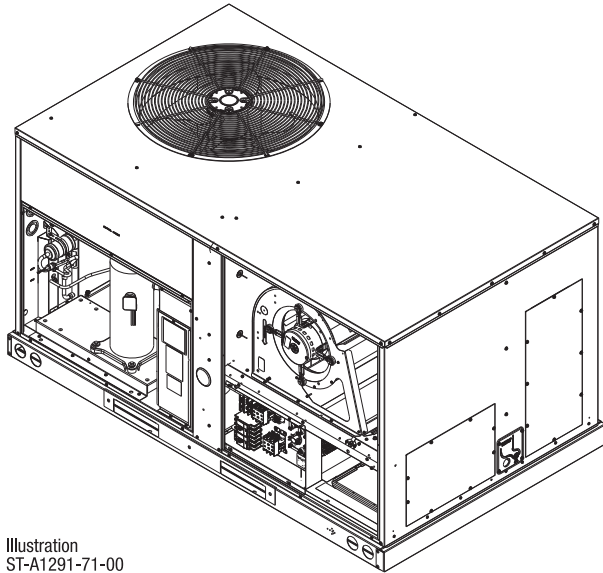
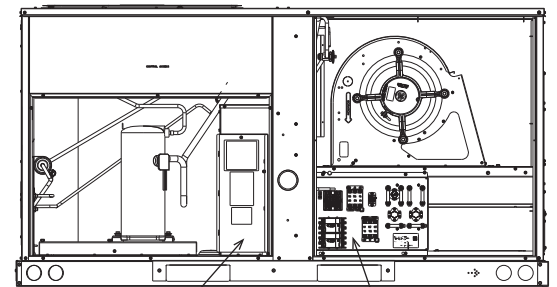

Illustration  
ST-A1291-71-00



SINGLE POINT WIRING BOX

ELECTRIC HEATER KIT



# NON-DDC ECONOMIZER FOR DOWNFLOW DUCT INSTALLATION

## Use in Select Field-Installed Options Only

RXRD-01MCDAM3—Single Enthalpy (Outdoor)

RRX-BV01—Dual Enthalpy Upgrade Kit

RRX-AR02—Optional Wall-Mounted CO<sub>2</sub> Sensor

- Features **Honeywell JADE™** Digital Controls
- Available Factory Installed or Field Accessory
- Gear Driven Direct Drive Actuator
- Fully Modulating (0-100%)
- Ultra Low Leak Dampers meet California Title 24 requirements and ASHRAE 90.1 2019
- AMCA 511 Certified Class 1A Leakage—1" WG of differential pressure tested to AMCA Standard 500-D
- Slip-In Design for Easy Installation
- Plug-In Polarized 12-pin Electrical Connections
- Standard Barometric Relief Damper
- Single Enthalpy with Dual Enthalpy Upgrade Kit Available
- CO<sub>2</sub> Input Sensor Available
- Field Assembled Hood Ships with Economizer
- Economizer Ships Complete for Down-flow Duct Application.
- Field Installed Power Exhaust Available
- Fault detection and diagnostics

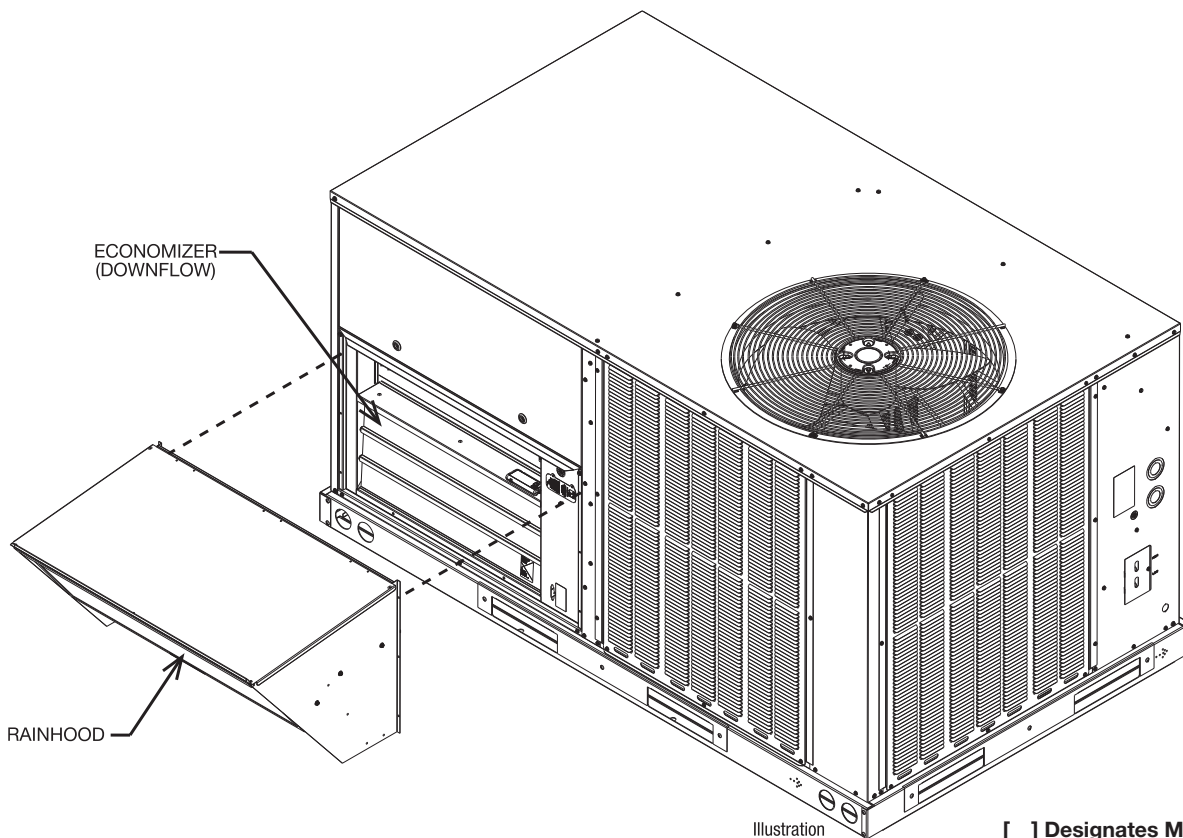
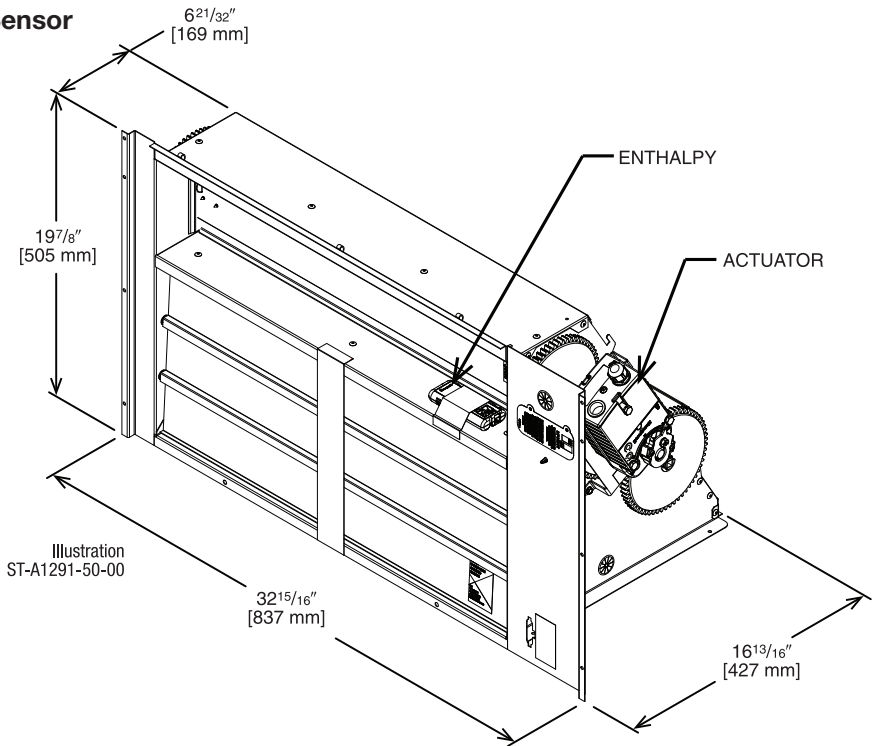

[ ] Designates Metric Conversions



# NON-DDC ECONOMIZER FOR HORIZONTAL DUCT INSTALLATION

## Field Installed Only

**RXRD-01MCDAM3—Single Enthalpy (Outdoor)**

**RXXR-BV01—Dual Enthalpy Upgrade Kit**

**RXXR-AR02—Wall-mounted CO<sub>2</sub> Sensor**

- Features **Honeywell JADE™** Digital Controls
- Available as a Field Installed Accessory Only
- Gear Driven Direct Drive Actuator
- Fully Modulating (0-100%)
- Ultra Low Leak Dampers meet California Title 24 requirements and ASHRAE 90.1 2019
- Slip-In Design for Easy Installation
- Standard Barometric Relief Damper
- Single Enthalpy with Dual Enthalpy Upgrade Kit Available
- CO<sub>2</sub> Input Sensor Available
- Field Assembled Hood Ships with Economizer
- Economizer Ships Complete for Horizontal Duct Application
- Field Installed Power Exhaust Available

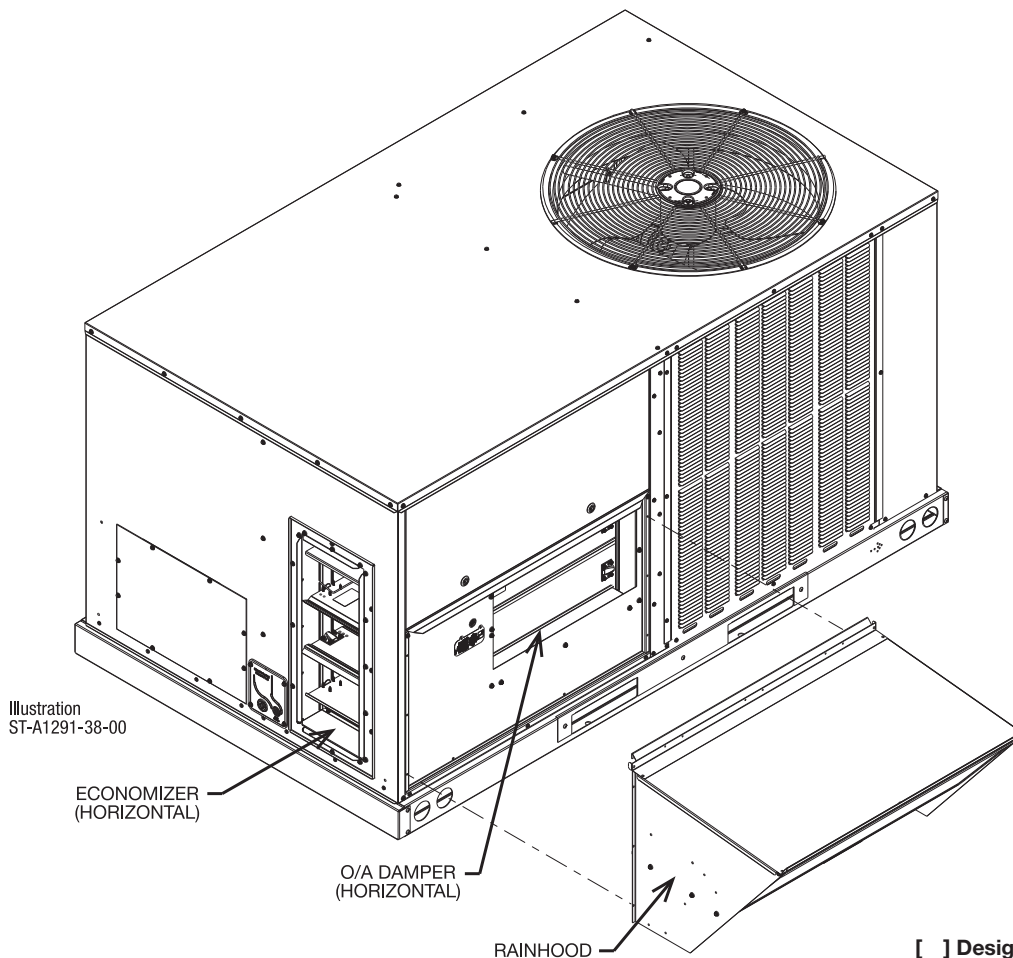
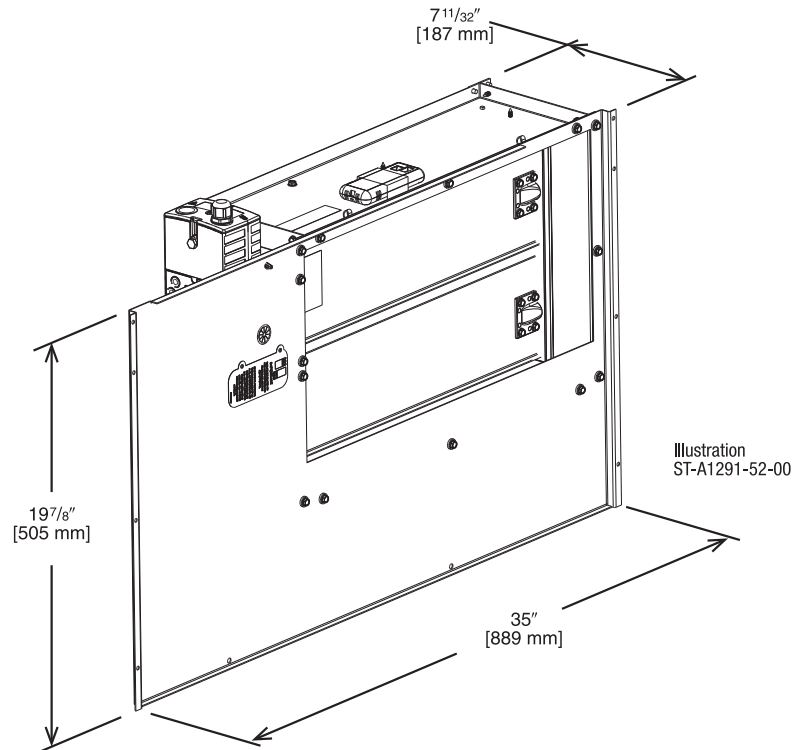

[ ] Designates Metric Conversions



## DDC—ECONOMIZER FOR DOWNFLOW DUCT INSTALLATION

### Use in Select Field Installed Options Only

**RXRD-01MDDBM3—Single Enthalpy (Outdoor)**  
**RXXR-BV02—Dual Enthalpy Upgrade Kit**  
**RXXR-AR02—Optional Wall-Mounted CO<sub>2</sub> Sensor**  
**RXRD-01MCDBM3**

- Features **Honeywell** Controls
- Available Factory Installed or Field Accessory
- Gear Driven Direct Drive Actuator
- Fully Modulating (0-100%)
- Ultra Low Leak Dampers meet California Title 24 requirements and ASHRAE 90.1 2019
- Slip-In Design for Easy Installation
- Standard Barometric Relief Damper
- Single Enthalpy with Dual Enthalpy Upgrade Kit Available
- CO<sub>2</sub> Input Sensor Available
- Field Assembled Hood Ships with Economizer
- Economizer Ships Complete for Downflow Duct Application.
- Optional Remote Minimum Position Potentiometer (270 ohm) (Honeywell #S963B1136) is Available from Prostock.
- Field Installed Power Exhaust Available
- Prewired for Smoke Detector
- If connected to a Building Automation System (BAS), all economizer functions can be viewed on the (BAS), or 16 x 2 LCD screen
- If connected to thermostat, all economizer functions can be viewed on 16 x 2 LCD screen

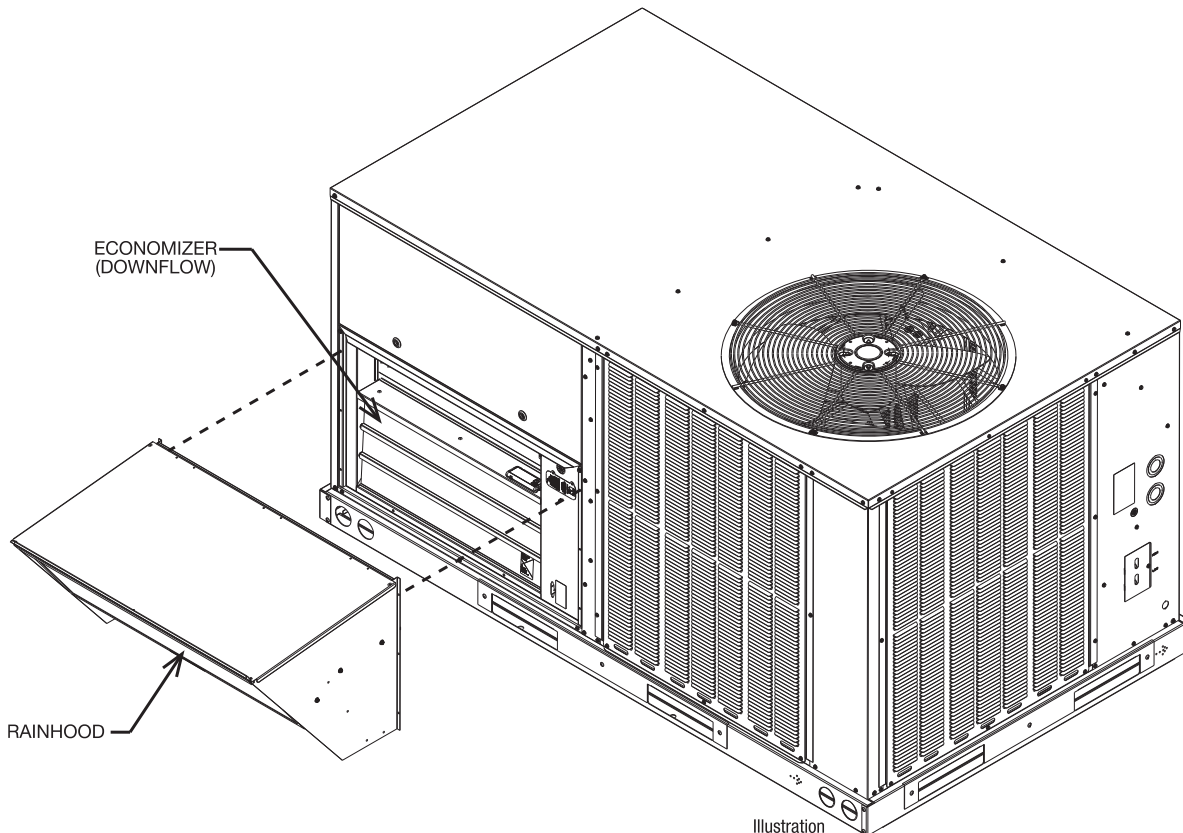
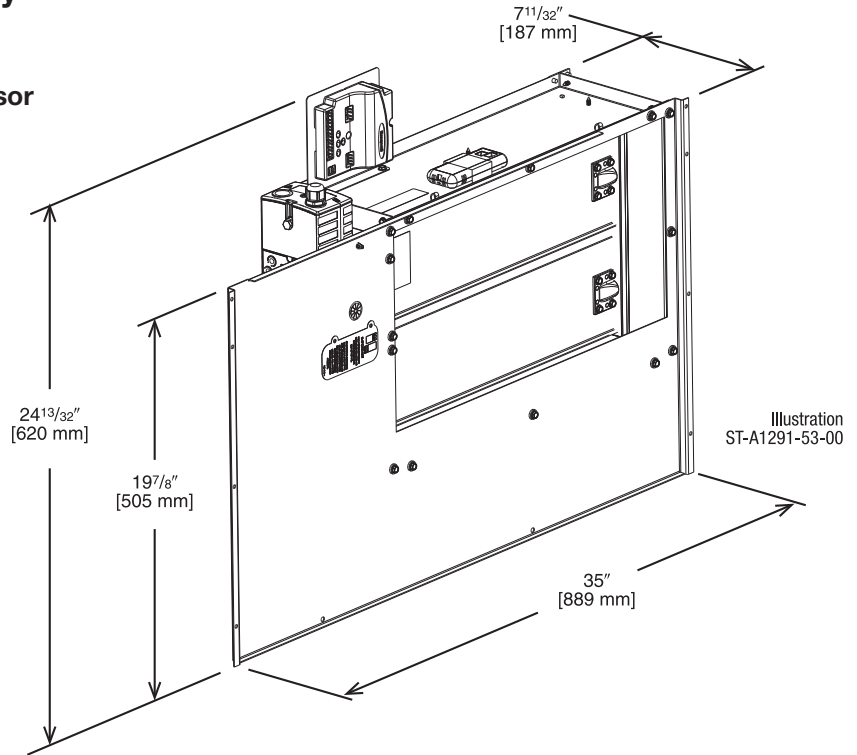

[ ] Designates Metric Conversions





## DDC—ECONOMIZER FOR HORIZONTAL DUCT INSTALLATION

### Field Installed Only

**RXRD-01MCHBM3—Single Enthalpy (Outdoor)**

**RXXR-BV02—Dual Enthalpy Upgrade Kit**

**RXXR-AR02—Wall-mounted CO<sub>2</sub> Sensor**

- Features **Honeywell** Controls
- Available as a Field Installed Accessory Only
- Gear Driven Direct Drive Actuator
- Fully Modulating (0-100%)
- Ultra Low Leak Dampers meet California Title 24 requirements and ASHRAE 90.1 2019
- Slip-In Design for Easy Installation
- Standard Barometric Relief Damper
- Single Enthalpy with Dual Enthalpy Upgrade Kit Available
- CO<sub>2</sub> Input Sensor Available
- Field Assembled Hood Ships with Economizer
- Economizer Ships Complete for Horizontal Duct Application
- Optional Remote Minimum Position Potentiometer (270 ohm) (Honeywell #S963B1136) is Available from Prostock
- Field Installed Power Exhaust Available
- If connected to a Building Automation System (BAS), all economizer functions can be viewed on the (BAS), or 16 x 2 LCD screen
- If connected to a thermostat, all economizer functions can be viewed on 16 x 2 LCD screen

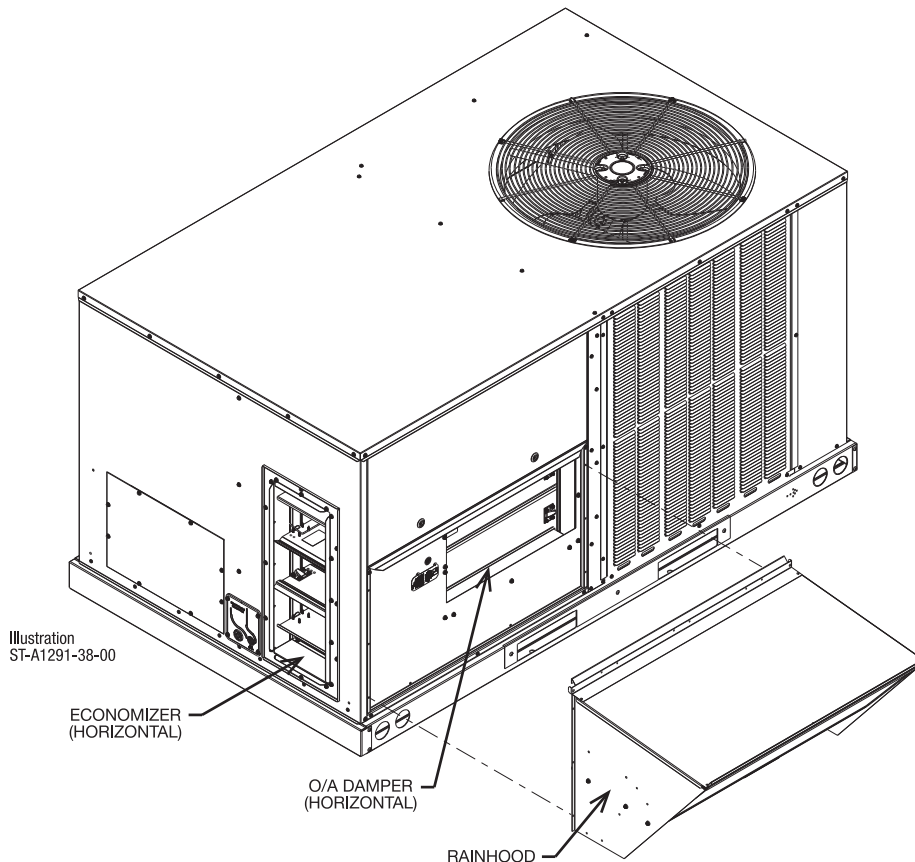
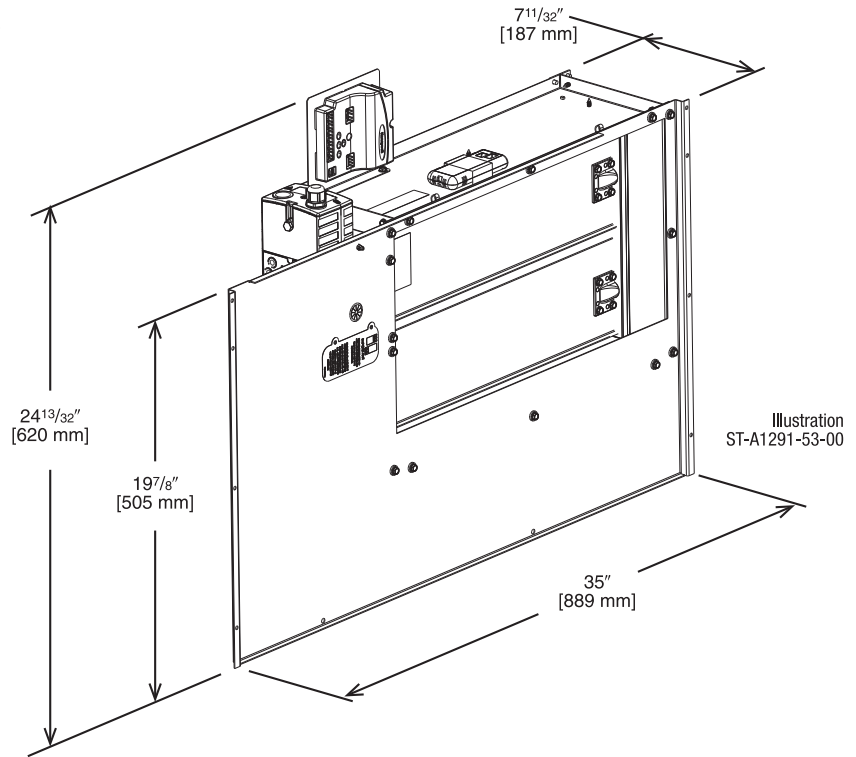

[ ] Designates Metric Conversions

# POWER EXHAUST KIT FOR RXRD-01MCDAM3, RXRD-01MCDBM3, RXRD-01MCHAM3, RXRD-01MCHBM3 ECONOMIZERS

RXRX-CCF02 (C, D, or Y\*)

\*Voltage Code

## VERTICAL AIRFLOW

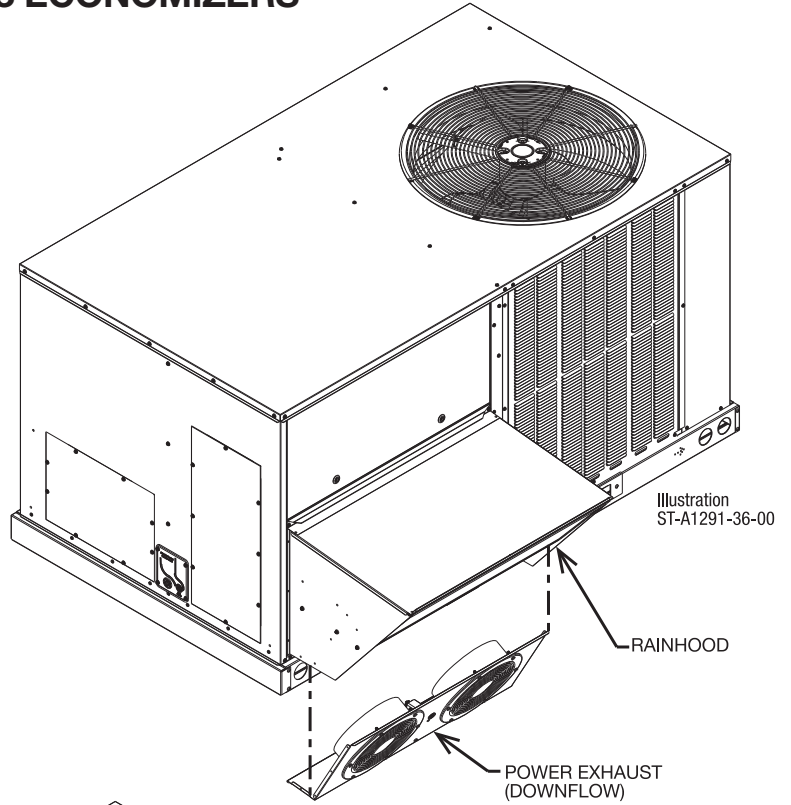

## HORIZONTAL AIRFLOW

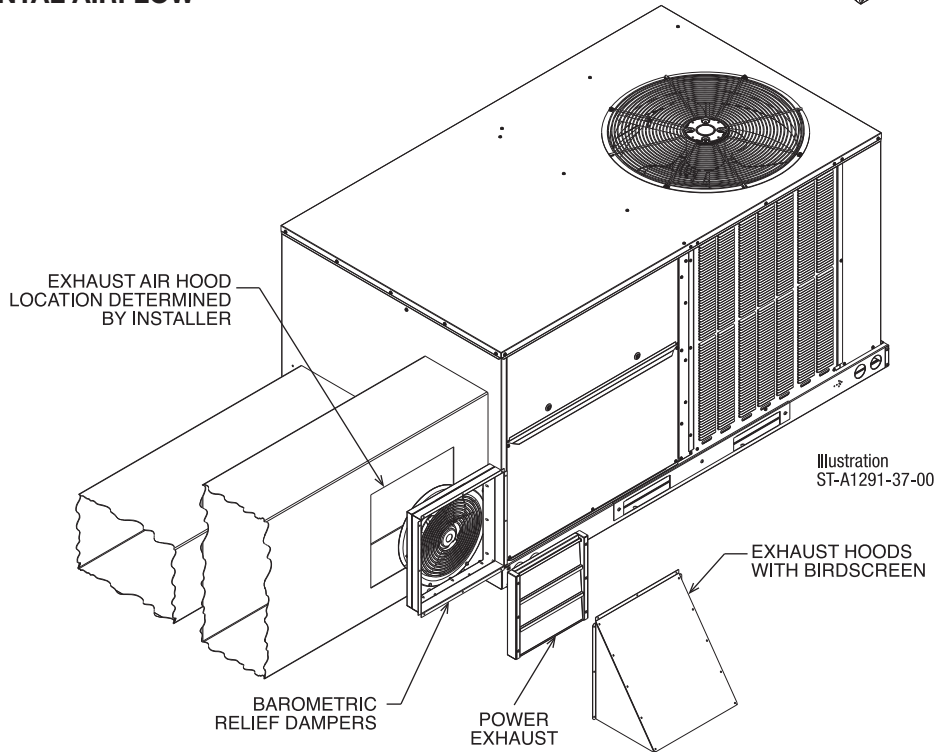

Model No.	No. of Fans	Volts	Phase	HP (ea.)	CFM [L/s]*	RPM	FLA (ea.)	LRA (ea.)
RXRX-CCF02C	2	208-230	1	0.47	2200	3000	1.55	1.1
RXRX-CCF02D	2	460	3	0.40	1970	2750	0.51	1.9





# FRESH AIR DAMPER

## MOTORIZED DAMPER KIT RXRF-ACB1

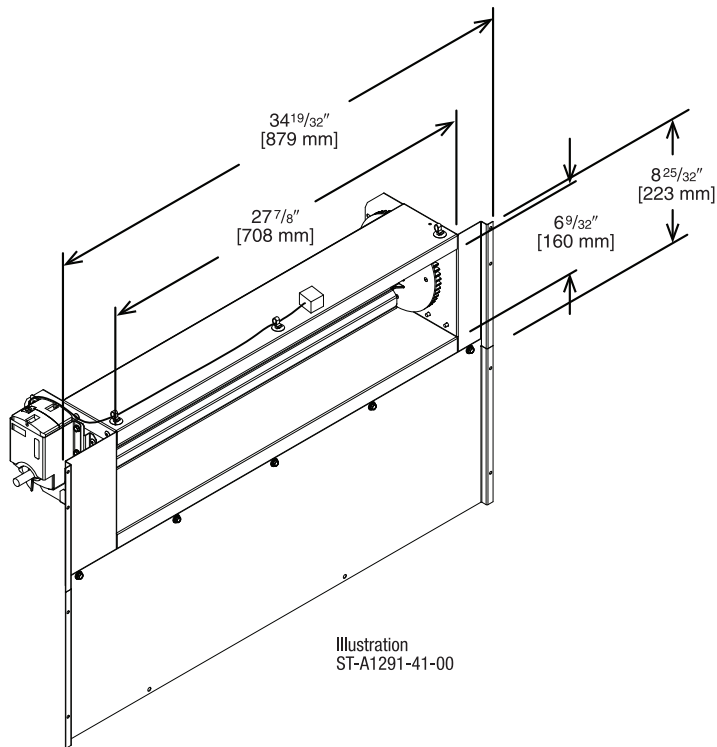

[ ] Designates Metric Conversions

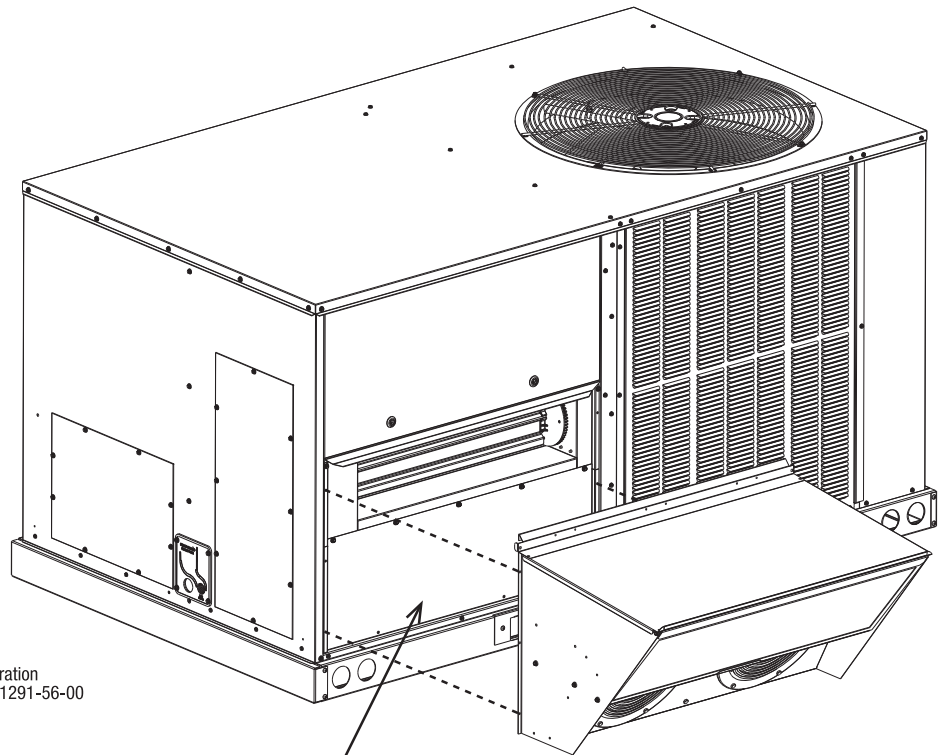

- Features **Siemens** Controls
- Gear Driven Direct Drive Actuator
- Adjustable to 2 positions
- Slip-In Design for Easy Installation
- Plug-In Polarized 12-pin and 4-pin Electrical Connections
- Pre-Configured—No Field Adjustments Necessary



# FRESH AIR DAMPER (Cont.)

RXRF-ACA1

## DOWNFLOW APPLICATION

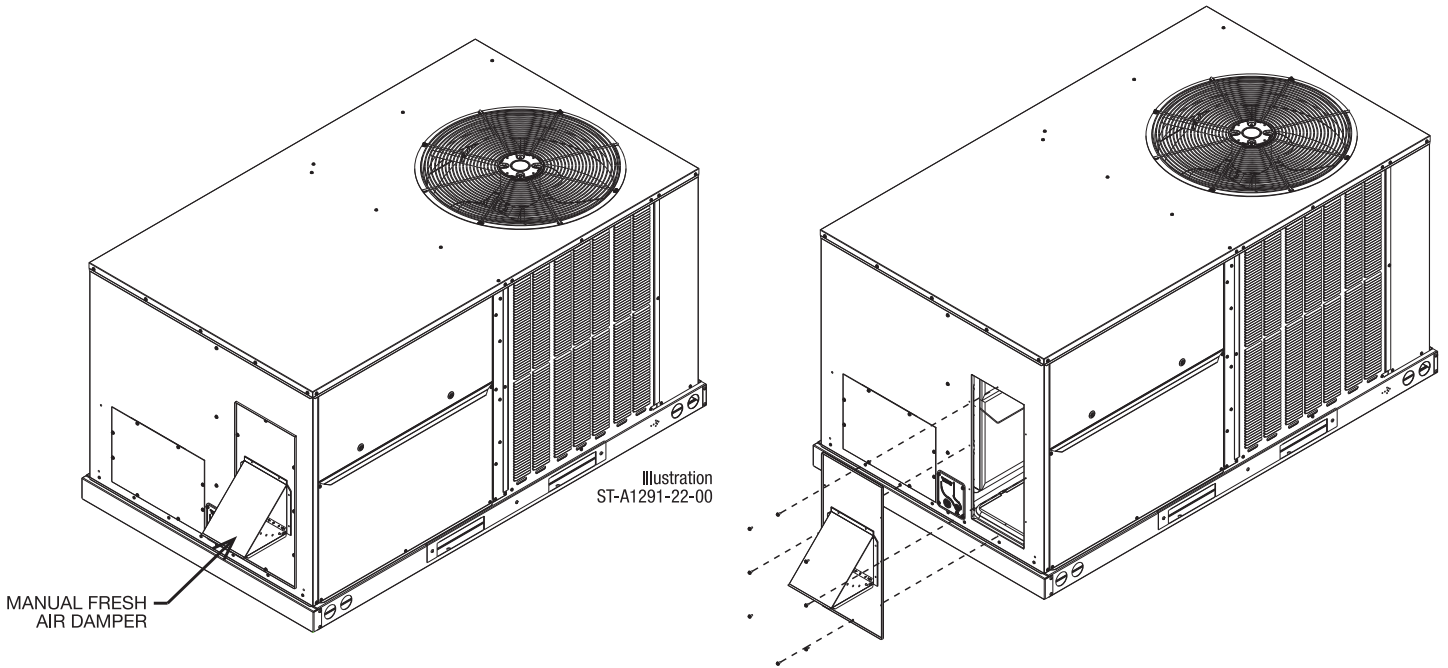

## HORIZONTAL APPLICATION

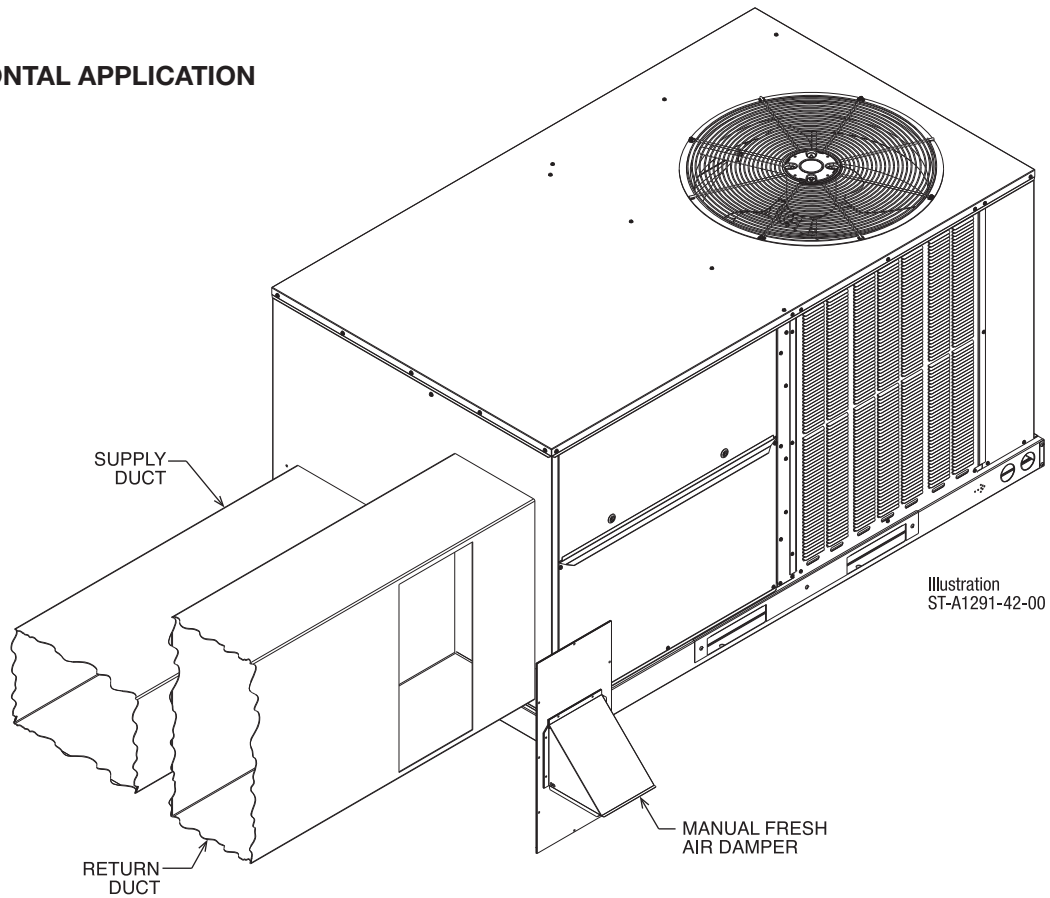

## ROOFCURBS (Full Perimeter)

- Rheem's roofcurb design can be utilized on all 3-5 ton [10.6-17.6 kW] RHPC- models.
- Two available heights (14" [356 mm] and 24" [610 mm]) for ALL models.
- Quick assembly corners for simple and fast assembly.
- Opening provided in bottom pan to match the "Thru the Curb" electrical, gas piping, condensate, connection opening provided on the unit base pan.
- 1" [25 mm] x 4" [102 mm] Nailer provided.
- Sealing gasket (40' [12.2 m]) provided with Roofcurb.
- Packaged for easy field assembly.

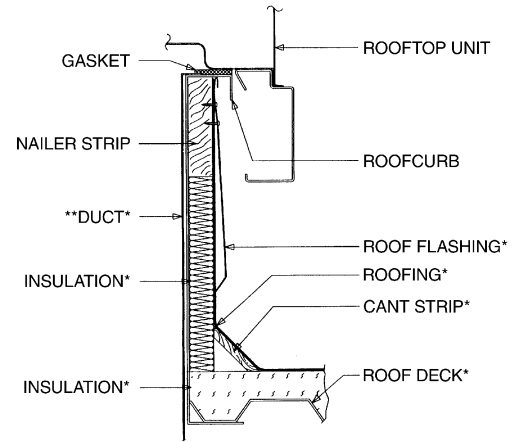

\*BY CONTRACTOR

\*\*FOR INSTALLATION OF DUCT AS SHOWN, USE RECOMMENDED DUCT SIZES FROM ROOFCURB INSTALLATION INSTRUCTIONS. FOR DUCT FLANGE ATTACHMENT TO UNIT, SEE UNIT INSTALLATION INSTRUCTIONS FOR RECOMMENDED DUCT SIZES.

Illustration  
ST-A0743-02

View	Roofcurb Model	Height of Curb
A	RXKG-DCC14	14" [356 mm]
A	RXKG-DCC24	24" [610 mm]

## ROOFCURB INSTALLATION

### VIEW A

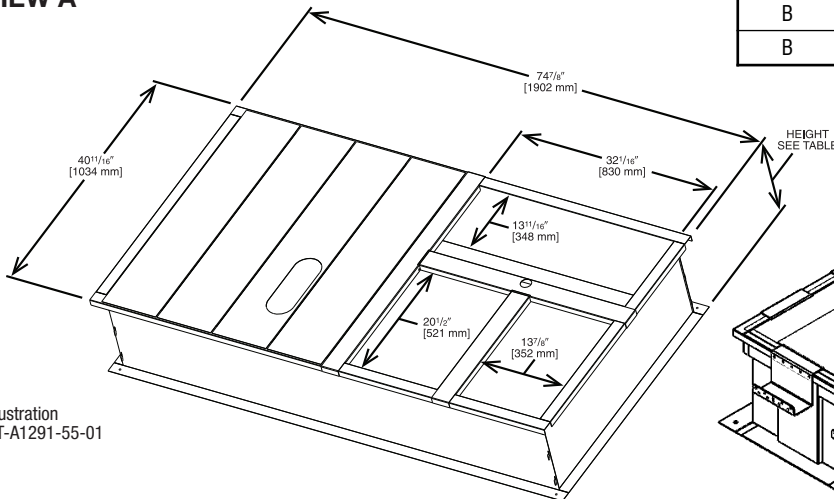
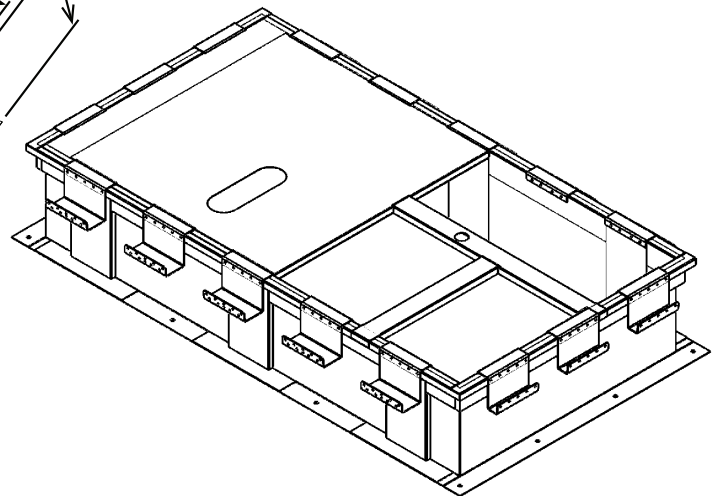

Illustration  
ST-A1291-55-01

View	Roofcurb Model	Dimensions
B	RXKG-DC14	74.875" x 40.688" x 14.0"
B	RXKG-DC24	74.875" x 40.688" x 24.0"

### WELDED ROOFCURB VIEW B



- State of Florida Approved: Approval Number FL 26981 for Technical Evaluation Report TER-20-28788 certifies the HVAC Unit and mounting methods for high wind resistance are compliant per Florida Building Code.

[ ] Designates Metric Conversions

# ROOFCURB ADAPTERS (Cont.)

RXR-DCCAE

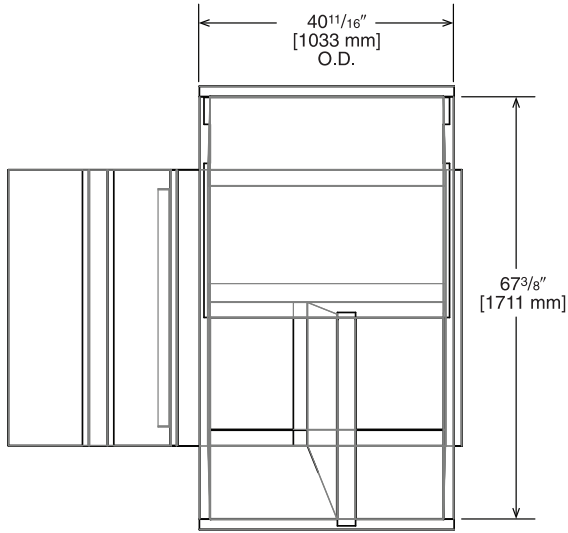

Approximate Static Pressure Drop
@1200 CFM = 0.05" w.g.
@2000 CFM = 0.19" w.g.

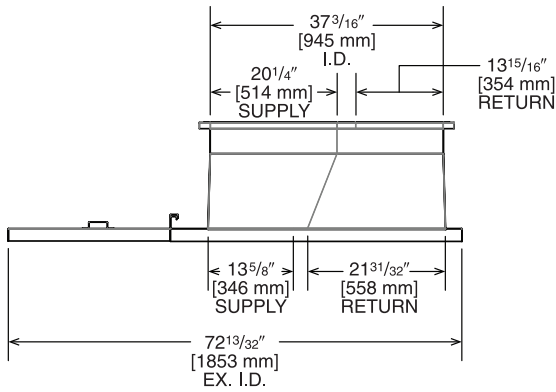
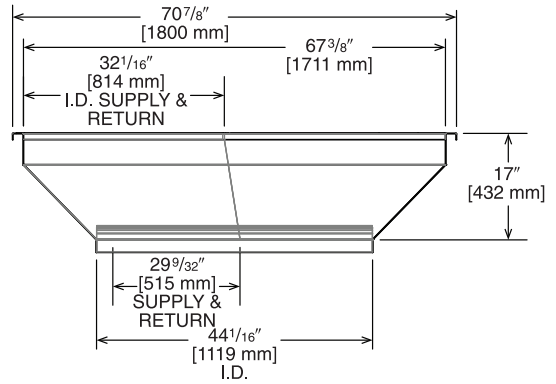
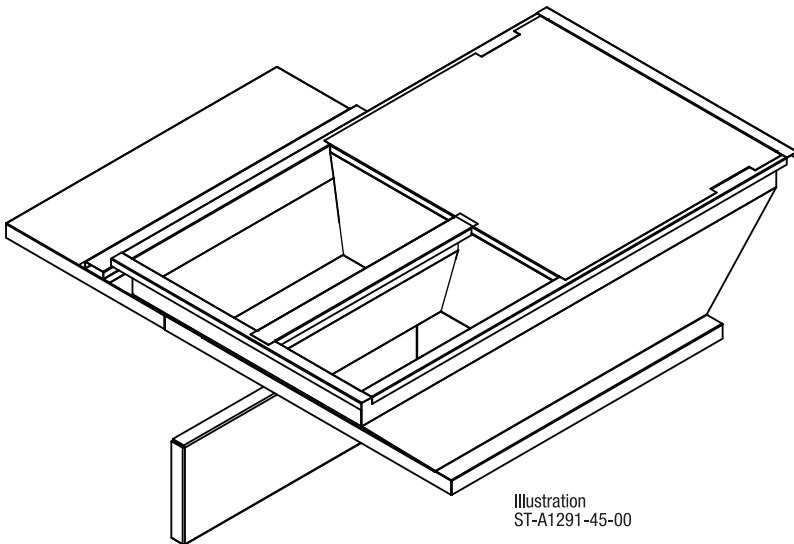

Illustration ST-A1291-44-00



TOP VIEW



[ ] Designates Metric Conversions

# CONCENTRIC DIFFUSER APPLICATION

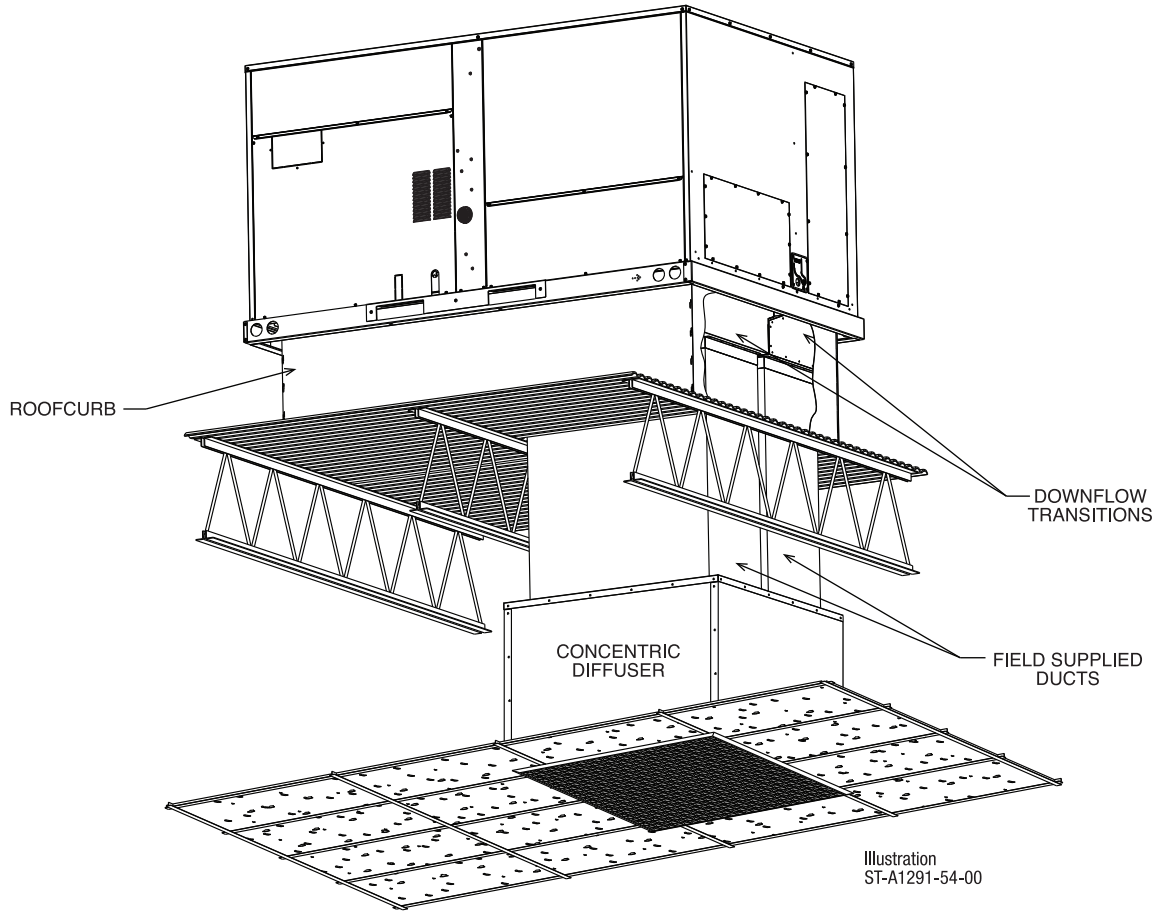



## DOWNFLOW TRANSITION DRAWINGS

### RXMC-DC01

- Used with AEF1800 or AED1800 Concentric Diffusers.

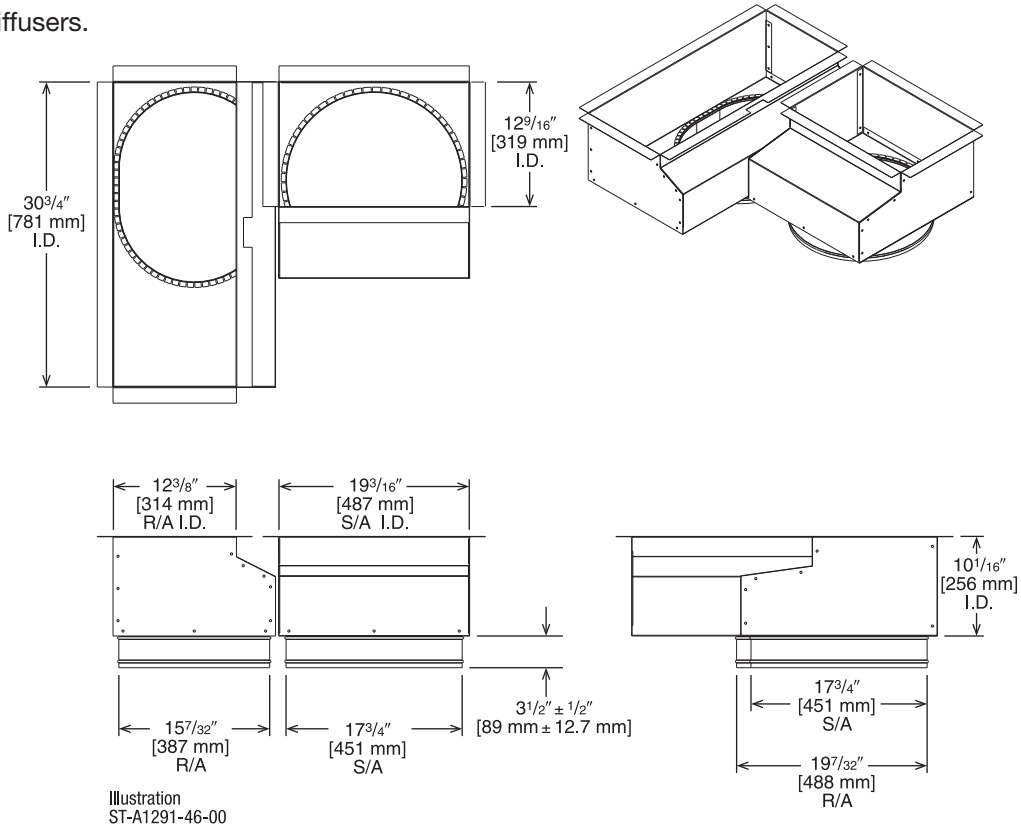

[ ] Designates Metric Conversions



## CONCENTRIC DIFFUSER – STEP DOWN

RXRN-AED1800 (3 and 4 Ton [10.6 and 14.1 kW] Models)

For Use With Downflow Transition (RXMC-DC01)  
 and 18" [457 mm] Round Supply and Return Ducts

- All aluminum diffuser with aluminum return air eggcrate.
- Built-in anti-sweat gasket.
- Molded fiberglass supports.
- Built-in hanging supports.
- Diffuser box constructed of sheetmetal insulated with 1" [25.4 mm] 1.5 lbs. [.7 kg] duct liner.

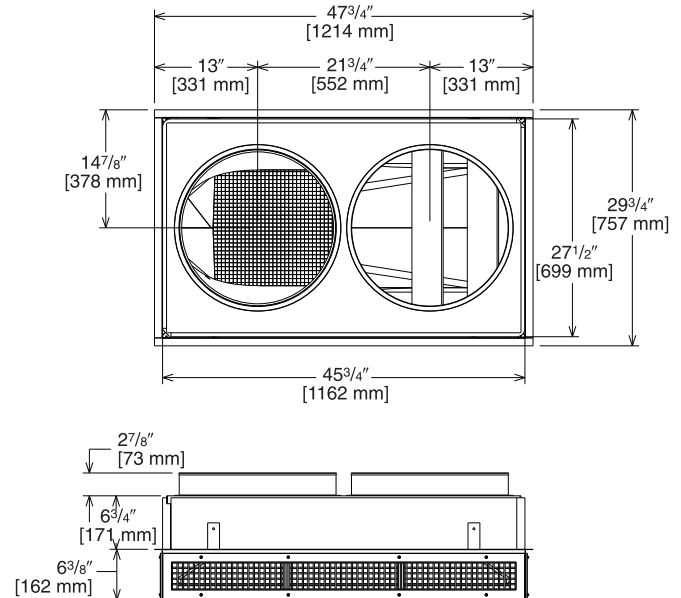
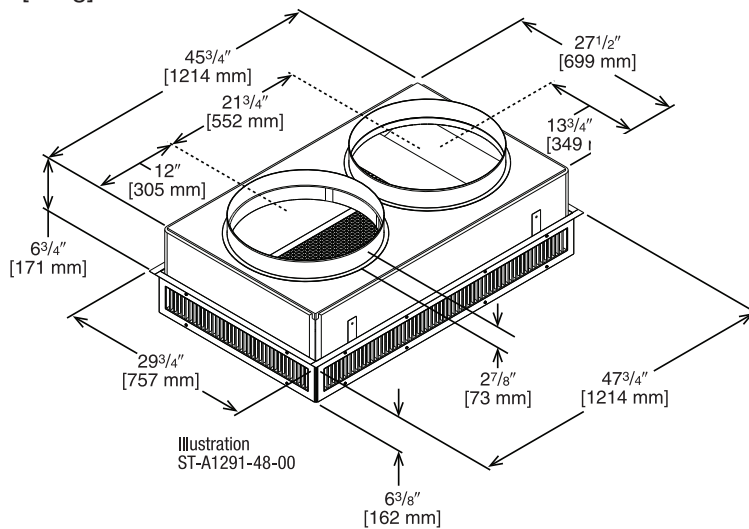

## ENGINEERING DATA<sup>①</sup>

Model No.	Flow Rate CFM [L/s]	Throw <sup>② ③</sup> Feet [m]	Neck Velocity fpm [m/s]	Noise Level <sup>④</sup> (dbA)
RXRN-AED1800	1000 [472]	9-23 [2.7-7.0]	391 [2.0]	12
	1200 [566]	10-24 [3.0-7.3]	469 [2.4]	15
	1400 [661]	12-26 [3.7-7.9]	547 [2.8]	19
	1600 [755]	13-28 [4.0-8.5]	625 [3.2]	21
	1800 [849]	15-30 [4.6-9.1]	703 [3.6]	26
	2000 [944]	17-32 [5.2-9.8]	781 [4.0]	30
	2400 [1133]	19-34 [5.8-10.4]	859 [5.8]	32

NOTES: ① All data is based on the air diffusion council guidelines.

② Throw data is based on 75 FPM Terminal Velocities using isothermal air.

③ Throw is based on diffuser blades being directed in a straight pattern.

④ Actual noise levels may vary due to duct design and do not include transmitted unit noise.  
 Adequate duct attenuation must be provided to reduce sound output from the unit.

[ ] Designates Metric Conversions

# FLUSH MOUNT CONCENTRIC DIFFUSER – FLUSH

RXRN-AEF1800 (3 and 4 Ton [10.6 and 14.1 kW])

For Use With Downflow Transition (RXMC-DC01)  
18" [457 mm] Round Supply and Return Ducts

- All aluminum diffuser with aluminum return air eggcrate.
- Built-in anti-sweat gasket.
- Molded fiberglass supports.
- Built-in hanging supports.
- Diffuser box constructed of sheetmetal insulated with 1" [25.4 mm] 1.5 lbs. [.7 kg] duct liner.

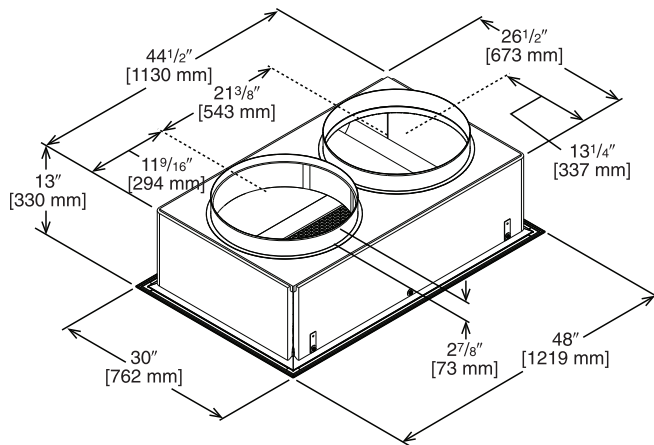
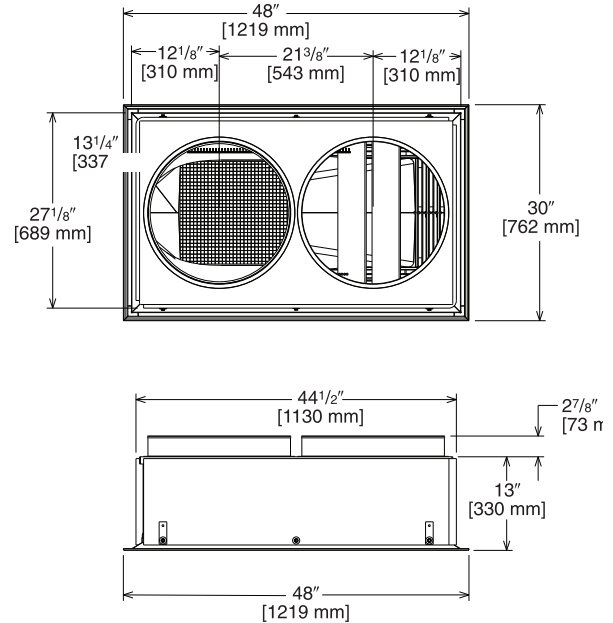

Illustration  
ST-A1291-49-00



## ENGINEERING DATA<sup>①</sup>

Model No.	Flow Rate CFM [L/s]	Throw <sup>② ③</sup> Feet [m]	Neck Velocity fpm [m/s]	Noise Level <sup>④</sup> (dbA)
RXRN-AEF1800	1000 [472]	9-12 [2.7-3.7]	663 [3.4]	20
	1200 [566]	12-16 [3.7-4.9]	714 [3.6]	25
	1400 [661]	15-20 [4.6-6.1]	765 [3.9]	30
	1600 [755]	17-23 [5.2-7]	816 [4.1]	30
	1800 [849]	20-26 [6.1-7.9]	867 [4.4]	35
	2000 [944]	22-29 [6.7-8.8]	918 [4.7]	40
	2400 [1133]	25-32 [7.6-9.8]	969 [4.9]	45

- NOTES: ① All data is based on the air diffusion council guidelines.  
 ② Throw data is based on 75 FPM Terminal Velocities using isothermal air.  
 ③ Throw is based on diffuser blades being directed in a straight pattern.  
 ④ Actual noise levels may vary due to duct design and do not include transmitted unit noise. Adequate duct attenuation must be provided to reduce sound output from the unit.

[ ] Designates Metric Conversions





# DOWNFLOW TRANSITION DRAWINGS

## RXMC-DC02

- Used with AEF2000 or AED2000 Concentric Diffusers.

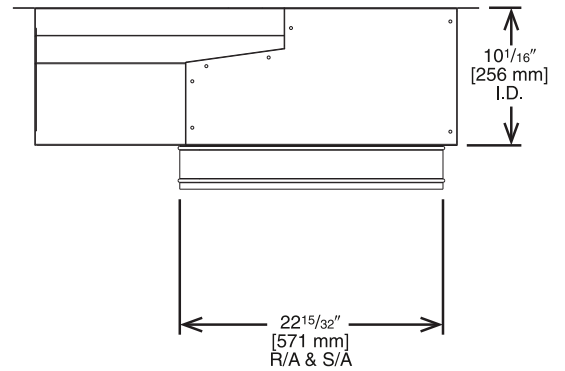
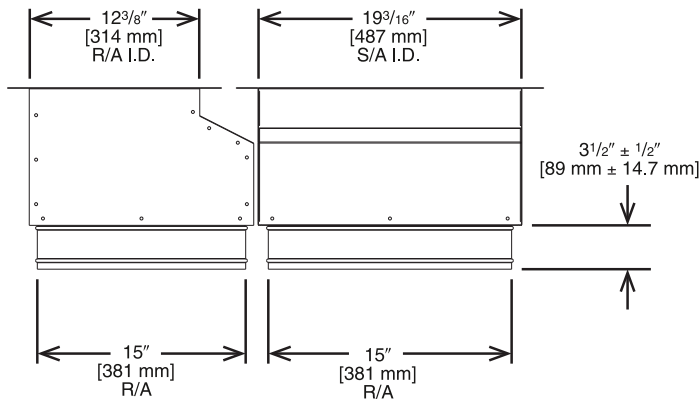
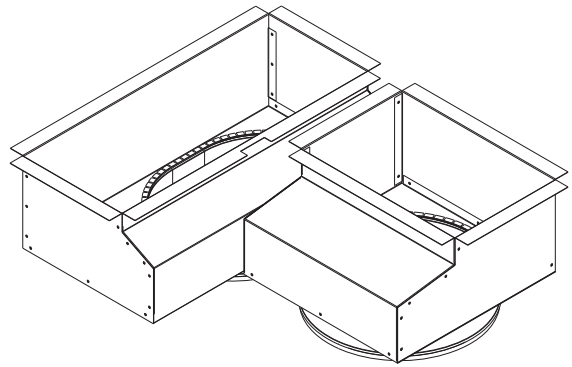
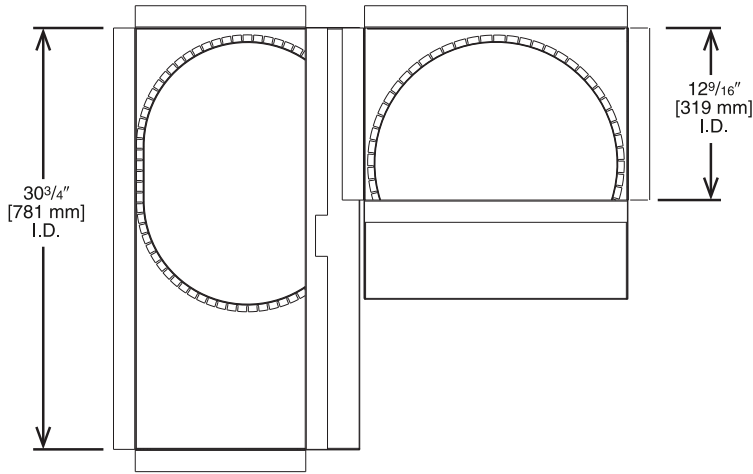

Illustration  
ST-A1291-47-00

[ ] Designates Metric Conversions

## CONCENTRIC DIFFUSER—STEP DOWN

RXRN-AED2000 (5 Ton [17.6 kW] Models)

For Use With Downflow Transition (RXMC-DC02)  
and 20" [508 mm] Round Supply and Return Ducts

- All aluminum diffuser with aluminum return air eggcrate.
- Built-in anti-sweat gasket.
- Molded fiberglass supports.
- Built-in hanging supports.
- Diffuser box constructed of sheetmetal insulated with 1" [25.4 mm] 1.5 lbs. [.7 kg] duct liner.

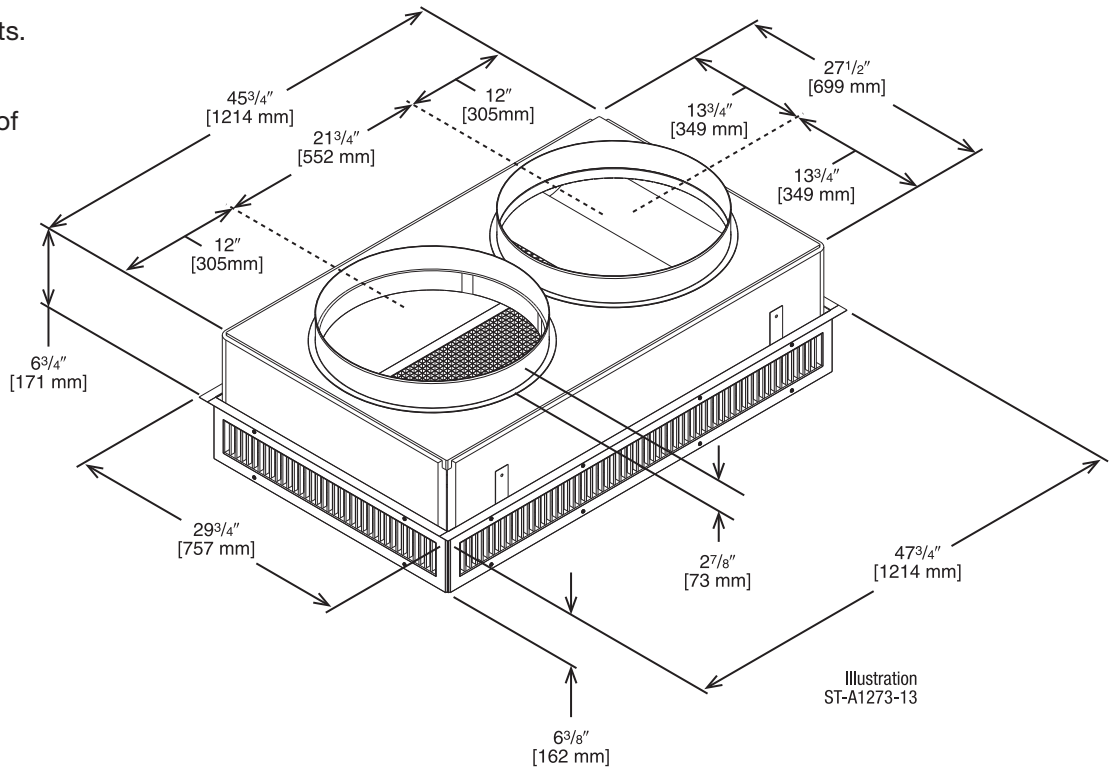

### ENGINEERING DATA<sup>①</sup>

Model No.	Flow Rate CFM [L/s]	Throw <sup>② ③</sup> Feet [m]	Neck Velocity fpm [m/s]	Noise Level <sup>④</sup> (dbA)
RXRN-AED2000	2600 [1222]	22-39 [6.7-11.9]	669 [3.4]	32
	2800 [1316]	23-40 [7.1-12.2]	720 [3.7]	38
	3000 [1410]	25-42 [7.6-12.8]	772 [3.9]	40
	3200 [1504]	26-43 [7.9-13.1]	823 [4.2]	41
	3400 [1598]	27-45 [8.2-13.7]	874 [4.4]	42

- NOTES: ① All data is based on the air diffusion council guidelines.  
 ② Throw data is based on 75 FPM Terminal Velocities using isothermal air.  
 ③ Throw is based on diffuser blades being directed in a straight pattern.  
 ④ Actual noise levels may vary due to duct design and do not include transmitted unit noise.  
 Adequate duct attenuation must be provided to reduce sound output from the unit.

[ ] Designates Metric Conversions

# FLUSH MOUNT CONCENTRIC DIFFUSER—FLUSH

RXRN-AEF2000 (5 Ton [17.6 kW])

For Use With Downflow Transition (RXMC-DC02)  
20" [508 mm] Round Supply and Return Ducts

- All aluminum diffuser with aluminum return air eggcrate.
- Built-in anti-sweat gasket.
- Molded fiberglass supports.
- Built-in hanging supports.
- Diffuser box constructed of sheetmetal insulated with 1" [25.4 mm] 1.5 lbs. [.7 kg] duct liner.

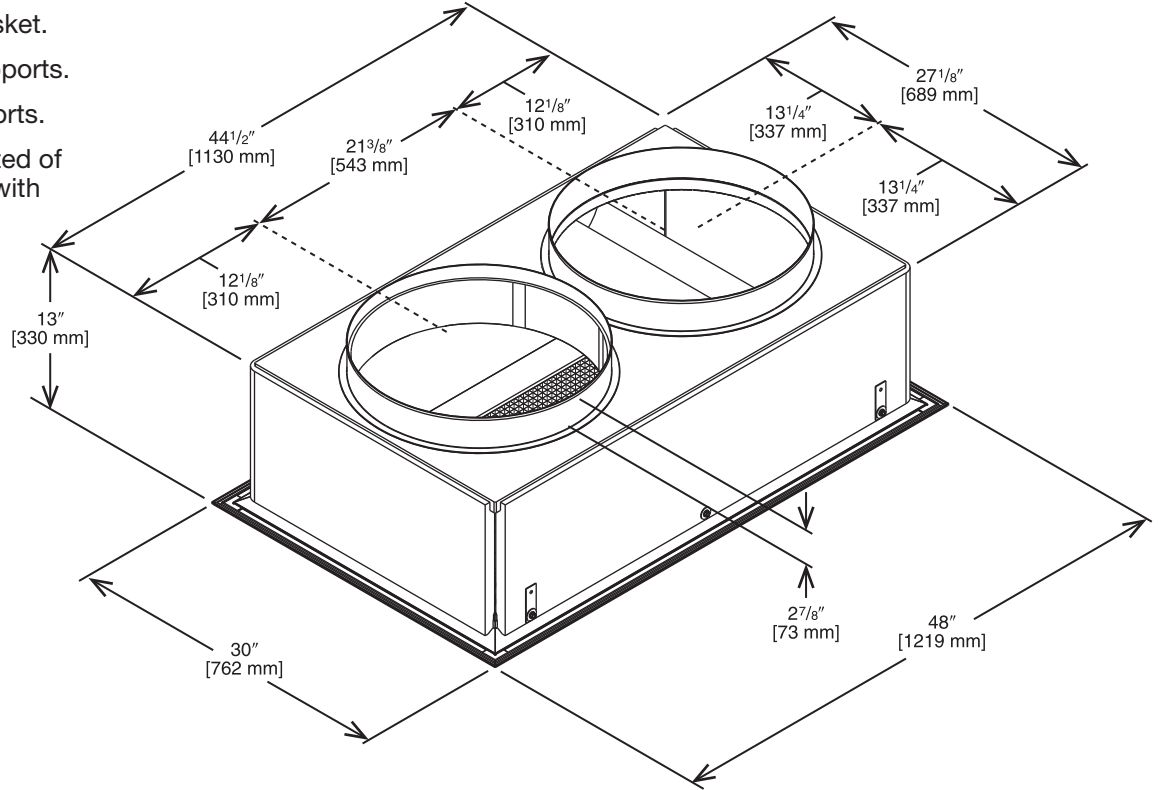

Illustration  
ST-A1273-14-00

## ENGINEERING DATA<sup>①</sup>

Model No.	Flow Rate CFM [L/s]	Throw <sup>② ③</sup> Feet [m]	Neck Velocity fpm [m/s]	Noise Level <sup>④</sup> (dba)
RXRN-AEF2000	2600 [1222]	17-24 [5.2-7.3]	663 [3.4]	30
	2800 [1316]	18-28 [5.5-8.5]	714 [3.6]	35
	3000 [1410]	20-30 [6.1-9.1]	765 [3.9]	35
	3200 [1504]	22-33 [6.7-10.1]	816 [4.1]	40
	3400 [1598]	23-37 [7-11.3]	867 [4.4]	40

- NOTES: ① All data is based on the air diffusion council guidelines.  
 ② Throw data is based on 75 FPM Terminal Velocities using isothermal air.  
 ③ Throw is based on diffuser blades being directed in a straight pattern.  
 ④ Actual noise levels may vary due to duct design and do not include transmitted unit noise.  
 Adequate duct attenuation must be provided to reduce sound output from the unit.

[ ] Designates Metric Conversions

**Guide Specifications RHPC—036-072**

You may copy this document directly into your building specification. This specification is written to comply with the 2016 version of the “master format” as published by the Construction Specification Institute. [www.csinet.org](http://www.csinet.org).

**ELECTRIC HEAT PUMP PACKAGED ROOFTOP****HVAC Guide Specifications****Size Range: 3 to 6 Nominal Tons****Section Description****23 06 80 Schedules for Decentralized HVAC Equipment****23 06 80.13 Decentralized Unitary HVAC Equipment Schedule**

## 23 06 80.13.A. Rooftop unit schedule

1. Schedule is per the project specification requirements.

**23 07 16 HVAC Equipment Insulation**

## 23 07 16.00.A. Evaporator fan compartment:

1. Interior cabinet surfaces shall be insulated with a minimum 1/2-in. thick, minimum 1.6 LB density, flexible fiberglass insulation bonded with foil face on the air side.
2. Insulation and adhesive shall meet NFPA 90A requirements for flame spread and smoke generation.
3. Insulation shall also be mechanically fastened with welded pin and retainer washer.

**23 09 13 Instrumentation and Control Devices for HVAC****23 09 13.23 Sensors and Transmitters:**

## 23 09 13.23.A. Thermostats

1. Thermostat must
  - a. Energize both “W” and “G” when calling for heat.
  - b. Have capability to energize 1 stage of cooling, and at least 1 stage of heating.
  - c. In 6 ton units, shall have the capability to energize to 2 stages.
  - d. Must include capability for occupancy scheduling.

**23 09 23 Direct-Digital Control System for HVAC**

## 23 09 23.00.A. RTU-C controller

1. Shall be ASHRAE 62-2001 compliant.
2. Shall accept 18-32VAC input power.
3. Shall have an operating temperature range from -40°F (-40°C) to 158°F (70°C), 10%– 95% RH (non-condensing).
4. Controller shall accept the following inputs: space temperature, setpoint adjustment, outdoor air temperature, indoor air quality, outdoor air enthalpy, fire shutdown, return air enthalpy, fan status, remote time clock/door switch.
5. Shall accept a CO<sub>2</sub> sensor in the conditioned space, and be Demand Control Ventilation (DCV) ready.
6. Shall provide the following outputs: Economizer, fan, cooling stage 1, cooling stage 2, heat stage 1, heat stage 2, exhaust, occupied.
7. Unit shall provide surge protection for the controller through a circuit breaker.
8. Shall have a field installed communication card allowing the unit to be able to communicate at a Baud rate of 19.2K or faster.
9. Shall have an LED display independently showing the status of activity on the communication bus, and processor operation.
10. Optional field installed BACnet® plug-in communication card which includes an EIA-485 protocol communication port, or an optional field installed LonWorks™ plug-in communications card.
11. Software upgrades will be accomplished by local download. Software upgrades through chip replacements are not allowed.
12. Shall be shock resistant in all planes to 5G peak, 11ms during operation, and 100G peak, 11ms during storage.
13. Shall be vibration resistant in all planes to 1.5G @ 20-300 Hz.
14. Shall support a bus length of 4000 ft max, 60 devices per 1000 ft section, and 1 RS-485 repeater per 1000 ft sections.

## 23 09 23.00.B. Open protocol, direct digital controller:

1. Shall be ASHRAE 62-2001 compliant.
2. Shall accept 18-30VAC, 50-60Hz, and consumer 15VA or less power.
3. Shall have an operating temperature range from -40°F (-40°C) to 130°F (54°C), 10% - 90% RH (non-condensing).
4. Shall have either a field installed BACnet® plug-in communication card which includes an EIA-485 protocol communication port, or a field installed LonWorks™ plug-in communications card.
5. The BACnet® plug in communication card shall include built-in protocol for BACNET (MS/TP and PTP modes)
6. The LonWorks™ plug in communication card shall include the Echelon processor required for all Lon applications.
7. Shall allow access of up to 62 network variables (SNVT). Shall be compatible with all open controllers

8. Baud rate Controller shall be selectable through the EIA-485 protocol communication port.
9. Shall have an LED display independently showing the status of serial communication, running, errors, power, all digital outputs, and all analog inputs.
10. Shall accept the following inputs: space temperature, setpoint adjustment, outdoor air temperature, indoor air quality, outdoor air enthalpy, compressor lock-out, fire shutdown, enthalpy switch, and fan status/filter status/humidity/remote occupancy.
11. Shall provide the following outputs: economizer, fan, cooling stage 1, cooling stage 2, heat stage 1, heat stage 2, exhaust.
12. Software upgrades will be accomplished by either local or remote download. No software upgrades through chip replacements are allowed.
13. Shall be natively equipped with Modbus communication protocol.

### **23 09 33 Electric and Electronic Control System for HVAC**

#### 23 09 33.00.A. General:

1. Shall be complete with self-contained low-voltage control circuit protected by a fuse on the 24-V transformer side.
2. Shall utilize color-coded wiring.
3. Unit shall include a minimum of one 8-pin screw terminal connection board for connection of control wiring.
4. Unit control board shall be provided with 7 segment readout via LCD display for status and diagnostics.

#### 23 09 33.00.B. Safeties:

1. Compressor over-temperature, over current.
2. Standard Low-pressure switch.
  - a. Units shall have low pressure, loss of charge automatic reset device that will shut off compressor when tripped.
  - b. Low pressure control:
    - Provides active protection in both heating and cooling modes at all outdoor ambient temperatures. The low pressure control is an automatic reset type and opens at approximately 15 psig and closes at approximately 40 psig. Operation is slightly different between cooling and heating modes.
3. Standard High-pressure switch.
  - a. Unit shall be equipped with high pressure switch device that will shut off compressor when tripped.
  - b. High Pressure control:
    - The high pressure control is an automatic reset type and opens at approximately 610 psig and closes at approximately 420 psig. The compressor and fan motor will stop when the high pressure control opens and will start again if the high side pressure drops to approximately 420 psig where the automatic reset high pressure control resets. If the high pressure control opens 3 times within a particular call for heating or cooling operation, the defrost control will lock out compressor and outdoor fan operation.
4. Automatic reset, motor thermal overload protector.
5. Heating section shall be provided with the following minimum protections:
  - a. High-temperature limit switches.
  - b. Induced draft motor pressure switch.
  - c. Flame rollout switch.
  - d. Flame proving controls.

### **23 09 93 Sequence of Operations for HVAC Controls**

#### **23 09 93.00 INSERT SEQUENCE OF OPERATION**

### **23 41 13 Panel Air Filters**

#### 23 41 13.00.A. Standard filter section shall

1. Shall consist of factory-installed, low velocity, throwaway 2-in. thick fiberglass filters of commercially available sizes.
2. Unit will accept both 2-in. and 4-in. filters.
3. Filter face velocity shall not exceed 365 fpm at nominal airflows.
4. Filters shall be accessible through an access panel with “no-tool” removal as described in the unit cabinet section of the specification (23 81 19.13.H).

**23 81 19 Self-Contained Heat Pumps****23 81 19.13 Small Capacity Self-Contained Heat Pumps**

## 23 81 19.13.A. General

1. Outdoor, rooftop mounted, electrically controlled, heating and cooling unit utilizing a(n) hermetic scroll compressor(s) for cooling duty and heat pump for heating duty.
2. Factory assembled, single-piece heating and cooling rooftop unit. Contained within the unit enclosure shall be all factory wiring, piping, controls, and special features required prior to field start-up.
3. Unit shall use environmentally safe, R410A refrigerant.
4. Unit shall be installed in accordance with the manufacturer's instructions.
5. Unit must be selected and installed in compliance with local, state, and federal codes.
6. Model and serial data shall be reprinted inside the control box.

## 23 81 19.13.B. Quality Assurance

1. Unit meets ASHRAE 90.1 2019 minimum efficiency requirements.
2. Unit shall be rated in accordance with AHRI Standards 210/240 or 340/360 and 10 CFR appendix M1 to subpart B or part 430.
3. Unit shall be designed to conform to ASHRAE 15.
4. Unit shall be UL-tested and certified in accordance with Standards and UL-listed and certified under Canadian standards as a total package for safety requirements.
5. Insulation and adhesive shall meet NFPA 90A requirements for flame spread and smoke generation.
6. Unit casing shall be capable of withstanding 1000-hour salt spray exposure per ASTM B117 (scribed specimen).
7. Unit shall be designed in accordance with ISO 9001:2015, and shall be manufactured in a facility registered by ISO 9001:2015.
8. Roof curb shall be designed to conform to NRCA Standards.
9. Unit shall be subjected to a completely automated run test on the assembly line. The data for each unit will be stored at the factory and must be available upon request.
10. Unit shall be designed in accordance with UL Standard 1995, Fifth Ed. including tested to withstand rain.
11. Five (5) years warranty for 3 phase, commercial applications compressor
12. Ten (10) years warranty for 3 phase, commercial applications aluminized heat exchanger
13. Twenty (20) years for 3 phase, commercial applications stainless steel heat exchanger
14. One (1) year warranty for 3 phase, commercial application parts

## 23 81 19.13.C. Delivery, Storage, and Handling

1. Unit shall be stored and handled per manufacturer's recommendations.
2. Lifted by crane requires either shipping top panel or spreader bars.
3. Unit shall only be stored or positioned in the upright position.

## 23 81 19.13.E. Project Conditions

1. As specified in the contract.

## 23 81 19.13.F. Operating Characteristics

1. Unit shall be capable of starting and running at 125°F (52°C) ambient outdoor temperature, meeting maximum load criteria of AHRI Standard 210/240 or 340/360 at ± 10% voltage.
2. Compressor with standard controls shall be capable of operation down to 50°F (10°C), ambient outdoor temperatures. Low ambient accessory kit is necessary if mechanically cooling at ambient temperatures to 0°F (-17.7°C).
3. Unit shall discharge supply air vertically or horizontally as shown on contract drawings.
4. Unit shall be factory configured for vertical supply & return configurations.
5. Unit shall be field convertible from vertical to horizontal configuration.

## 23 81 19.13.G. Electrical Requirements

1. Main power supply voltage, phase, and frequency must match those required by the manufacturer.

## 23 81 19.13.H. Unit Cabinet

1. Unit cabinet shall be constructed of galvanized steel.
2. Unit cabinet exterior paint shall be pre-painted steel.
3. The sheet-metal cabinet shall be constructed of 18-gauge material for structural components with an underlying coat of G90.
4. Evaporator fan compartment interior cabinet insulation shall conform to AHRI Standards 210 or 360 minimum exterior sweat criteria. Interior surfaces shall be insulated with a minimum 1/2-in. thick, 1.6 lb. density, flexible fiberglass insulation, foil faced on the air side. Aluminum foil-faced fiberglass insulation shall be used in the gas heat compartment.

5. Shall utilize uniform screw sizing
  6. Base of unit shall have a location for thru-the-base gas and electrical connections standard.
  7. Base Rail
    - a. Unit shall have base rails on a minimum of 4 sides.
    - b. Holes shall be provided in the base rails for rigging shackles to facilitate maneuvering and overhead rigging.
    - c. Holes shall be provided in the base rail for moving the rooftop for fork truck.
    - d. Base rail shall be a minimum of 14 gauge thickness.
  8. Condensate pan and connections:
    - a. Shall be a sloped condensate drain pan made of a non-corrosive material and be removable for cleaning.
    - b. Shall comply with ASHRAE Standard 62.
    - c. Shall use a 3/4" NPT drain connection, possible either through the bottom or side of the drain pan. Connection shall be made per manufacturer's recommendations.
    - d. Shall be able to slide out completely.
    - e. Shall be separate from the coil.
  9. Standard factory installed condensate overflow sensor
  10. Top panel:
    - a. Shall be a single piece top panel over indoor section.
  11. Electrical Connections
    - a. All unit power wiring shall enter unit cabinet a single, factory-prepared, continuous raised flange opening in the basepan.
    - b. Thru-the-base capability
      - i. Standard unit shall have a thru-the-base electrical location(s) using a raised, continuous raised flange opening in the basepan.
      - ii. No basepan penetration, other than those authorized by the manufacturer, is permitted.
  12. Component access panels (standard)
    - a. Cabinet panels shall be easily opened for servicing.
    - b. Panels covering control box, indoor fan, indoor fan motor, gas components (where applicable), and filters shall have hinges with 1/4 turn fasteners on units with factory-installed hinged option.
    - c. 1/4 fasteners shall be permanently attached.
- 23 81 19.13.J. Coils
1. Standard Aluminum/MicroChannel Coils:
    - a. Standard evaporator and condenser coils shall be aluminum.
    - b. Evaporator and condenser coils shall be leak tested to 150 psig, pressure tested to 400 psig, and qualified to burst test at 2,200 psi.
- 23 81 19.13.K. Refrigerant Components
1. Refrigerant circuit shall include the following control, safety, and maintenance features:
    - a. TXV metering system shall prevent mal-distribution of two-phase refrigerant.
    - b. Refrigerant filter drier.
    - c. Service gauge connections on suction and discharge lines.
    - d. External pressure gauge ports access shall be located in front exterior of cabinet.
    - e. External gauge ports shall be lockable.
  2. Compressors
    - a. Unit shall use one fully hermetic scroll compressor.
    - b. Compressor motors shall be cooled by refrigerant gas passing through motor windings.
    - c. Compressors shall be internally protected from high discharge temperature conditions.
    - d. Compressors shall be protected from an over-temperature and over-ampereage conditions by an internal, motor overload device.
    - e. Compressor shall be factory mounted on rubber grommets.
    - f. Compressor motors shall have internal line break thermal and current overload protection.
    - g. Crankcase heaters shall not be required for normal operating range.
    - h. Compressor shall have molded electrical plug.

## 23 81 19.13.L. Filter Section

1. Filters access is specified in the unit cabinet section of this specification.
2. Filters shall be held in place by metal rods, facilitating easy removal and installation.
3. Shall consist of factory-installed, low velocity, throw-away 2-in. thick fiberglass filters.
4. Filter face velocity shall not exceed 320 fpm at nominal airflows.
5. Filters shall be standard, commercially available sizes.
6. Only one size filter per unit is allowed.

## 23 81 19.13.M. Evaporator Fan and Motor

1. Evaporator fan motor:
  - a. Shall have permanently lubricated bearings
  - b. Shall have inherent automatic-reset thermal overload protection.
2. Direct Drive Evaporator Fan:
  - a. Direct drive ECM technology with (5) dedicated speed selections as follows: fan, low, high, AC low static, AC high static.
  - b. Blower fan shall be double-inlet type with forward-curved blades.
  - c. Shall be constructed from steel with a corrosion resistant finish and dynamically balanced.
3. Blower Assembly
  - a. Entire assembly shall be able to slide out completely
  - b. Shall be able to slide-out without the removal of the roof and condenser fan motors.

## 23 81 19.13.N. Condenser Fans and Motors

1. Condenser fan motors:
  - a. Shall be a totally enclosed motor.
  - b. Shall use permanently lubricated bearings.
  - c. Shall have inherent thermal overload protection with an automatic reset feature.
  - d. Shall use a shaft-down design. Shaft-up designs including those with "rain-slinger devices" shall not be allowed.
2. Condenser Fans shall:
  - a. Shall be a direct-driven propeller type fan
  - b. Shall have blades riveted to corrosion-resistant steel spiders and shall be dynamically balanced.

## 23 81 19.13.O. Special Features

1. Integrated Economizers:
  - a. Integrated, gear-driven parallel modulating blade design type capable of simultaneous economizer and compressor operation.
  - b. Independent modules for vertical or horizontal return configurations shall be available. Vertical return modules shall be available as a factory installed option.
  - c. Damper blades shall be galvanized steel with metal gears. Plastic or composite blades on intake or return shall not be acceptable.
  - d. Shall include all hardware and controls to provide free cooling with outdoor air when temperature and/or humidity are below setpoints.
  - e. Shall be equipped with gear driven dampers for both the outdoor ventilation air and the return air for positive air stream control.
  - f. Shall be equipped with low-leakage dampers, not to exceed 2% leakage at 1 in. wg pressure differential.
  - g. Shall be capable of introducing up to 100% outdoor air.
  - h. Shall be equipped with a barometric relief damper capable of relieving up to 35% return air, depending on the airflow.
  - i. Shall be designed to close damper(s) during loss-of-power situations with spring return built into motor.
  - j. Enthalpy sensor shall be provided as standard. Outdoor air sensor set point shall be adjustable and shall range from 40 to 100°F / 4 to 38°C. Additional sensor options shall be available as accessories.
  - k. The economizer controller shall also provide control of an accessory power exhaust unit function. Factory set at 70%, with a range of 0% to 100%.
  - l. The economizer shall maintain minimum airflow into the building during occupied period and provide design ventilation rate for full occupancy. A remote potentiometer may be used to override the damper set point.



- m. Dampers shall be completely closed when the unit is in the unoccupied mode.
  - n. Economizer controller shall accept a 2-10Vdc CO<sub>2</sub> sensor input for IAQ/DCV control. In this mode, dampers shall modulate the outdoor-air damper to provide ventilation based on the sensor input.
  - o. Actuator shall be direct coupled to economizer gear. No linkage arms or control rods shall be acceptable.
  - p. Economizer controller shall provide indications when in free cooling mode, in the DCV mode, or the exhaust fan contact is closed.
  - q. Economizer wire harness will have provision for smoke detector available in supply and return options.
  - r. Shall provide fault detection and diagnostics (FDD) system in accordance with local code. Faults shall be communicated out on an alarm signal.
2. Manual damper
    - a. Manual damper package shall consist of damper, air inlet screen, and rain hood which can be preset to admit up to 50% outdoor air for year round ventilation.
  3. Condenser Coil Hail Guard Assembly
    - a. Shall protect against damage from hail.
    - b. Shall be louvered style.
  4. Unit-Mounted, Non-Fused Disconnect Switch:
    - a. Switch shall be factory or field installed.
    - b. Switch shall be internally mounted with external access.
    - c. National Electric Code (NEC) and UL approved non-fused switch shall provide unit power shutoff.
    - d. Shall be accessible from outside the unit.
    - e. Shall provide local shutdown and lockout capability.
  5. Convenience Outlet:
    - a. Non-Powered convenience outlet.
    - b. Outlet shall be powered from a separate 115-120v power source.
    - c. A transformer shall not be included.
    - d. Outlet shall be field-installed and internally mounted with easily accessible 115-v female receptacle.
    - e. Outlet shall include 15 amp GFI receptacle with independent fuse protection.
    - f. Outlet shall be accessible from outside the unit.
  6. Propeller Power Exhaust:
    - a. Power exhaust shall be used in conjunction with an integrated economizer.
    - b. Independent modules for vertical or horizontal return configurations shall be available.
    - c. Horizontal power exhaust is shall be mounted in return ductwork.
    - d. Power exhaust shall be controlled by economizer controller operation. Exhaust fans shall be energized when dampers open past the 0-100% adjustable setpoint on the economizer control.
    - e. Capable of adjustable but constant volume.
  7. Roof Curbs (Vertical):
    - a. Formed galvanized steel with wood nailer strip and shall be capable of supporting entire unit weight.
    - b. Permits installation and securing of ductwork to curb prior to mounting unit on the curb.
  8. Return Air Enthalpy Sensor:
    - a. The return air enthalpy sensor shall be used in conjunction with an outdoor air enthalpy sensor to provide differential enthalpy control.
  9. Indoor Air Quality (CO<sub>2</sub>) Sensor:
    - a. Shall be able to provide demand ventilation indoor air quality (IAQ) control.
    - b. The IAQ sensor shall be available in duct mount, wall mount, or wall mount with LED display. The set point shall have adjustment capability.

10. Smoke detectors:
  - a. Shall be a Four-Wire Controller and Detector.
  - b. Shall be environmental compensated with differential sensing for reliable, stable, and drift-free sensitivity.
  - c. Shall use magnet-activated test/reset sensor switches.
  - d. Shall have tool-less connection terminal access.
  - e. Shall have a recessed momentary switch for testing and resetting the detector.
  - f. Controller shall include:
    - One set of normally open alarm initiation contacts for connection to an initiating device circuit on a fire alarm control panel
    - Two Form-C auxiliary alarm relays for interface with rooftop unit or other equipment
    - One Form-C supervision (trouble) relay to control the operation of the Trouble LED on a remote test/reset station
    - Capable of direct connection to two individual detector modules.
    - Can be wired to up to 14 other duct smoke detectors for multiple fan shutdown applications.
11. Barometric relief
  - a. Shall include damper, seals, hard-ware, and hoods to relieve excess building pressure.
  - b. Damper shall gravity-close upon shutdown.
12. Time Guard
  - a. Shall prevent compressor short cycling by providing a 5-minute delay ( $\pm 2$  minutes) before restarting a compressor after shutdown for any reason.
  - b. One device shall be required per compressor.
13. Standard Factory installed Overflow Switch
  - a. Switch shall monitor the condensate level in drain pan and stops compression operation when overflow conditions occur.

**BEFORE PURCHASING THIS APPLIANCE, READ IMPORTANT ENERGY COST AND EFFICIENCY INFORMATION AVAILABLE FROM YOUR RETAILER.**

**GENERAL TERMS OF LIMITED WARRANTY\***

Rheem will furnish a replacement for any part of this product which fails in normal use and service within the applicable periods stated, in accordance with the terms of the limited warranty.

**\*For complete details of the Limited and Conditional Warranties, including applicable terms and conditions, contact your local contractor or the Manufacturer for a copy of the product warranty certificate.**

**Compressor**

Commercial Applications.....Five (5) Years

**Parts**

Commercial Applications .....One (1) Year



The new degree of comfort.™

*In keeping with its policy of continuous progress and product improvement, Rheem reserves the right to make changes without notice.*

Rheem Heating, Cooling & Water Heating • 5600 Old Greenwood Road  
Fort Smith, Arkansas 72908 • [www.rheem.com](http://www.rheem.com)

Rheem Canada Ltd./Ltée • 125 Edgeware Road, Unit 1  
Brampton, Ontario • L6Y 0P5



INTEGRATED AIR & WATER