

⚠ DO NOT destroy this manual. Please read carefully and keep in a safe place for future reference

⚠ WARNING

If the information in these instructions is not followed exactly, a fire or explosion may result causing property damage, personal injury or death.

⚠ FOR YOUR SAFETY!

- **DO NOT** store or use gasoline, other flammable vapors or liquids or other combustible materials in the vicinity of this or any other appliance. Doing so may result in a explosion or fire.

-WHAT TO DO IF YOU SMELL GAS

- **DO NOT** try to light any appliance.
- **DO NOT** touch any electrical switch.
- **DO NOT** use any phone in your home.
- Immediately call your gas supplier from a neighbor's phone. And follow the gas supplier's instructions.
- If you cannot reach your gas supplier, call the fire department.
- **DO NOT** return to your home until authorized by the gas supplier or fire department.

-ALWAYS REFER TO THIS MANUAL

- Installation and service must be performed by a qualified installer, service agency, or gas supplier.

RESIDENTIAL HIGH EFFICIENCY WATER HEATER USE & CARE MANUAL



CONTENTS

Important Safety Information

General Safety Precautions 2-5

Product Information

Components Diagram..... 6

Installation

Location 7

Thermal Expansion 8

Water Connections 8

To Fill the Water Heater..... 8

Gas Supply 9

Leak Testing..... 9

Condensate 9

High Altitude 10

Wiring 11

Typical Installation 11

Space Heating Connections..... 12

Venting and Combustion Air Inlet..... 13 - 32

Check List 33

Operation

Lighting Instructions 34

Safety Precautions..... 35

User Interface

Start Up 36

Temperature Adjustment 36

Schedule Settings 37

Time/Date Settings 37

WiFi Status 38

Alarms and Service Alerts..... 39

Maintenance

Routine Preventive Maintenance..... 40

Seasonal Operation..... 40

Venting System..... 40

Before You Call For Service

Troubleshooting Tips..... 41, 42

Error Codes 43- 48

Replacement Parts

Instructions For Placing a Parts Order 49

Wiring and Schematic Diagrams 50, 51

How to Obtain Service Assistance 52

READ ALL SAFETY INFORMATION

Your safety and the safety of others are very important. There are many important safety messages in this manual and on your appliance. Always read and follow all safety messages.



This is the safety alert symbol. Recognize this symbol as an indication of important safety information! This symbol alerts you to safety hazards that could result in physical harm or death.

All safety messages will follow the safety alert symbol and either the word "DANGER," "WARNING," "CAUTION," or "NOTICE."

These words mean:

⚠ DANGER: An imminently hazardous situation that will result in death or serious injury.

⚠ WARNING: A potentially hazardous situation that can result in death or serious injury and/or damage to property.

⚠ CAUTION: A potentially hazardous situation that may result in minor or moderate injury.

NOTICE: Attention is called to observe a specified procedure or maintain a specific condition.

FOR YOUR RECORDS:

Write the model and serial numbers here:

You can find them on a label on the appliance.

Staple sales slip or cancelled check here.

Proof of the original purchase date is needed to obtain service under the warranty.

GENERAL SAFETY PRECAUTIONS

To meet residential water use needs, the temperature on this water heater is adjustable up to 160°F (71°C). However, water temperatures over 125°F (52°C) can cause severe burns instantly or death from scalds. This is the preferred starting point for setting the control for supplying general purpose hot water.

Safety and energy conservation are factors to be considered when setting the water temperature. The most energy efficient operation will result when the temperature setting is the lowest value that satisfies the needs consistent with the application.

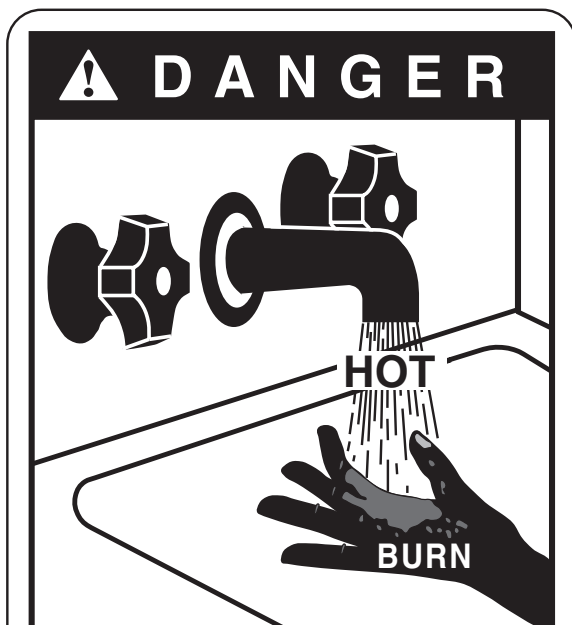

Water temperature over 125°F (52°C) can cause severe burns instantly or death from scalds.

Children, disabled and elderly persons are at greatest risk of being scalded.

See instructions manual before setting temperature of water heater.

Feel water Before bathing or showering.

Temperature limiting valves are available, see manual.

Maximum water temperatures occur just after burner has shut off. To find the temperature of the hot water being delivered, turn on a hot water faucet, and place a thermometer in the hot water stream, and read the thermometer.

The following chart details the relationship of water temperature and time to scald injury and may be used as a guide in determining the safest water temperature for your applications.

TIME / TEMPERATURE RELATIONSHIPS IN SCALDS

Water Temperature	Time to Produce Serious Burn
120° F (49°C)	More than 5 minutes
125° F (52°C)	1½ to 2 minutes
130° F (54°C)	About 30 seconds
135° F (57°C)	About 10 seconds
140° F (60°C)	Less than 5 seconds
145° F (63°C)	Less than 3 seconds
150° F (66°C)	About 1½ seconds
155° F (68°C)	About 1 second

Table courtesy of Shriners Burn Institute

The temperature of the water in the heater can be regulated by setting the temperature on the display (see "User Interface" section). To comply with safety regulations the water heater temperature was adjusted to lowest setting before the water heater was shipped from the factory. The illustration information on "User Interface" section shows the display and how to adjust the water temperature.

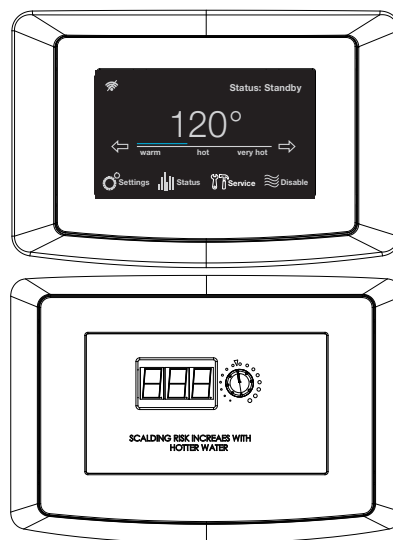

See Section "User Interface" for setting the temperature.

⚠️ DANGER:

Hotter water increases the potential for hot water SCALDS.

NOTICE:

Mixing valves are recommended for reducing point of use water temperature by mixing hot and cold water in branch water lines. It is recommended that a mixing valve complying with the Standard for Temperature Actuated Mixing Valves for Hot Water Distribution Systems, ASSE 1017 be installed. See Water Connections for more details. For additional information, contact a licensed plumber or the local plumbing authority.

GENERAL SAFETY PRECAUTIONS

Be sure to read and understand the entire Use and Care Manual before attempting to install or operate this water heater. It may save you time and money. Pay particular attention to the Safety Instructions. Failure to follow these warnings could result in serious bodily injury or death. Should you have problems understanding the instructions in this manual, or have any questions, STOP, and get help from a qualified service technician, or the local gas utility.

NOTICE: This water heater is equipped with a flammable vapor sensor that will automatically shut down the water heater in the presence of gasoline vapors and some other flammable vapors. If the flammable vapor sensor shuts down the water heater, contact a qualified service technician. Clear any hazardous materials and ventilate the area around the water heater. DO NOT turn off the appliance or adjust the ON/OFF switch in any way. DO NOT tamper with the flammable vapor sensor. DO NOT submerge the flammable vapor sensor in water. DO NOT allow the flammable vapor sensor to come into contact with any substances such as bleach or cleaners. See the "Gas Control LED Error Codes" Section of this manual for a list of error codes.

Flammable Materials:

⚠️ WARNING:

Gasoline, as well as other flammable materials and liquids (which include but are not limited to adhesives, solvents, paint thinners, etc.), and the vapors they produce are extremely dangerous. DO NOT handle, use, or store gasoline or other flammable or combustible materials anywhere near or in the vicinity of a water heater or any other appliance. Be sure to read and follow the warning label pictured below and other labels on the water heater and in this manual. Failure to do so can result in property damage, bodily injury, or death.

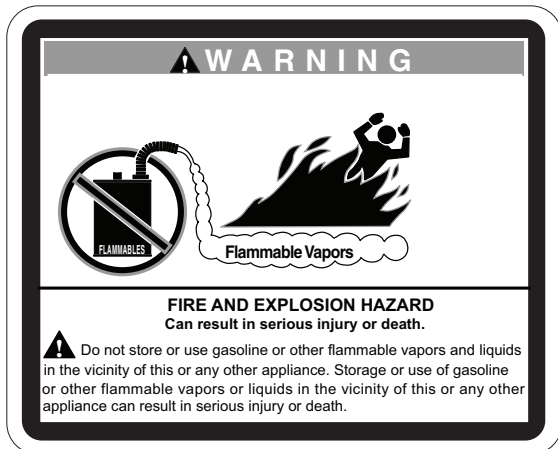

Venting:

⚠️ DANGER:

Failure to properly vent the water heater to the outdoors as outlined in the "Venting and Combustion Air Inlet" section of this manual can result in unsafe operation of the water heater. To avoid the risk of fire, explosion, or asphyxiation from carbon monoxide, never operate this water heater unless it is properly vented and has adequate air supply for proper operation. Be sure to inspect the Venting and Combustion Air Inlet section for proper installation at initial start-up and, at least, annually, thereafter. Refer to the "Maintenance" section of this manual for more information regarding vent system inspections.

Natural Gas and Liquefied Petroleum Safety

⚠️ DANGER:

LIQUEFIED PETROLEUM MODELS — Propane (LP) gas, must be used with great caution.

- It is heavier than air and will collect first in lower areas making it hard to detect at nose level.
- Make sure to look and smell for LP leaks before attempting ignition of the water heater. Use a soapy solution to check all gas fittings and connections. Bubbling at a connection indicates a leak that must be corrected.
- When smelling to detect an LP leak, be sure to sniff near the floor too.
- Gas detectors are recommended in LP applications and their installation should be in accordance with the manufacturer's recommendations and local laws, rules, regulations, or customs.
- It is recommended that more than one method be used to detect leaks in LP applications.

IF LP GAS IS PRESENT OR SUSPECTED:

- DO NOT attempt to find the cause yourself;
- DO NOT try to light any appliance;
- DO NOT touch any electrical switch;
- DO NOT use any phone in your building.
- Leave the building immediately and make sure your family and pets leave also.
- Leave the doors open for ventilation and contact the gas supplier, a qualified service agency or the fire department.
- Stay away from the house (or building) until the service call has been made, the leak is corrected and a qualified agency has determined the area to be safe.

GENERAL SAFETY PRECAUTIONS

⚠️ **WARNING:**

Both LP and natural gas have an odorant added to help detection. Some people may not physically be able to smell or recognize this odorant. If unsure or unfamiliar about the smell associated with LP or natural gas, ask the gas supplier. Other conditions, such as "Odorant Fade", which causes the odorant to "fade" or diminish in intensity can also hide or camouflage a gas leak.

⚠️ **DANGER:**

Water heaters utilizing Liquefied Petroleum gas (LP) are different from natural gas models. A natural gas heater will not function safely on LP gas and vice versa. No attempt should ever be made to convert a heater from natural gas to LP gas. To avoid possible equipment damage, personal injury or fire: DO NOT connect this water heater to a fuel type not in accordance with the unit's data plate. Propane for propane units; natural gas for natural gas units. These units are not certified for any other type fuel.

⚠️ **WARNING:**

LP appliances should not be installed below-grade (for example, in a basement) if such installation is prohibited by federal, state, or local laws, rules, regulations or customs.

Electrical Safety

⚠️ **DANGER:**

- Shock Hazard – Make sure the electrical power to the water heater is off to avoid electric shock that will result in death or serious personal injury.

⚠️ **WARNINGS:**

- For your safety, the information in this manual must be followed to minimize the risk of fire, explosion, or electric shock that can result in death, personal injury, and/or property damage.
- Field wiring connections and electrical grounding must comply with local codes or, in the absence of local codes, with the latest edition of the National Electrical Code, ANSI/NFPA 70, or in Canada, Canadian Electrical Code, CAN/CSA C22.1, Part 1.

⚠️ **CAUTIONS:**

- Label all wires prior to disconnecting for service. Wiring errors can cause dangerous and improper operation. Verify correct operation after servicing.
- For your safety, burner inspection and cleaning should be performed only by qualified service personnel.
- Make certain the power to the water heater is OFF before removing the unit cover panel. Exposed electrical components and moving parts can cause personal injuries.
- For your safety, DO NOT attempt repair of electrical wiring, gas piping, remote control, burners, vent connectors, or other safety devices. Refer repairs to qualified service personnel.

Inspect Shipment

Carefully inspect the water heater for damage before proceeding with the installation. Of specific interest should be combustion air-inlet piping assembly, exhaust-tee, or damage to blower-valve assembly. If you find damage, DO NOT install or attempt any repair to the water heater. Contact the manufacturer as detailed under "HOW TO OBTAIN ASSISTANCE".

COMPONENTS DIAGRAM

Front View

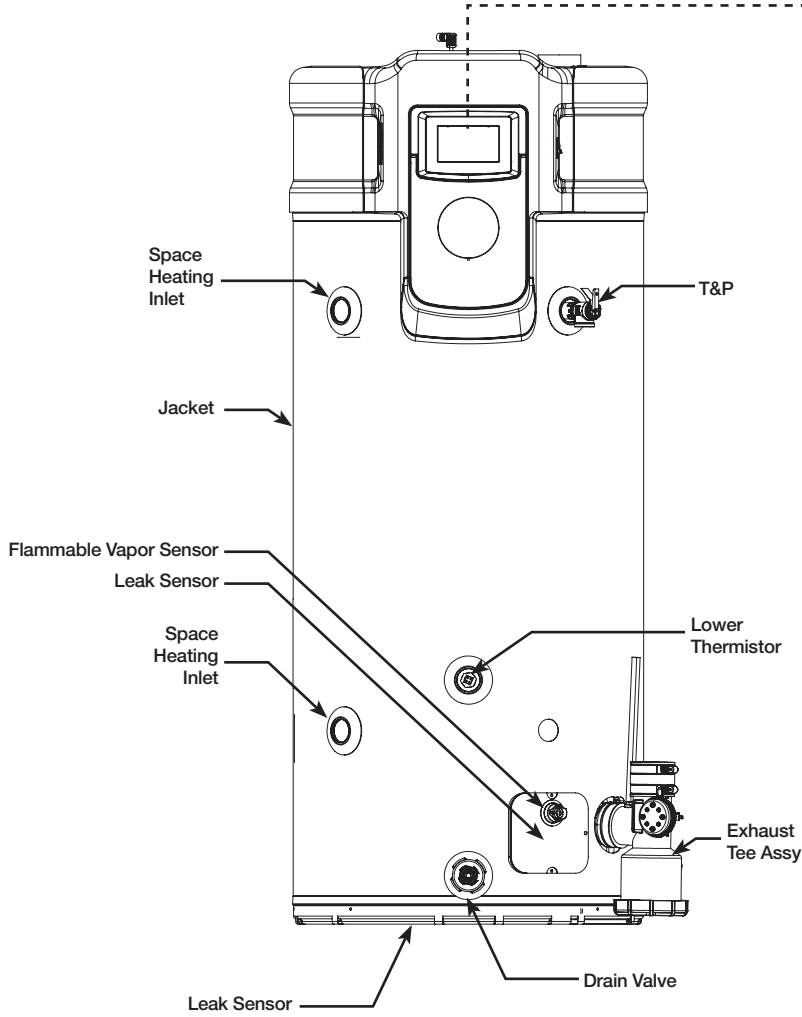

Touch Display

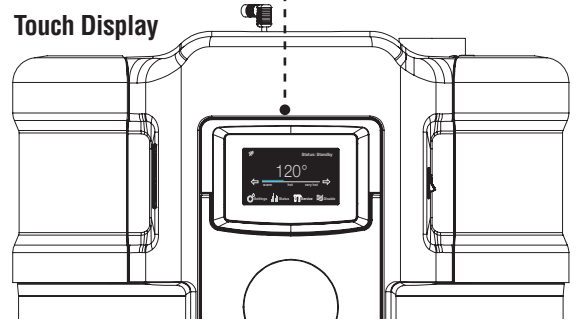

Manual Controlled

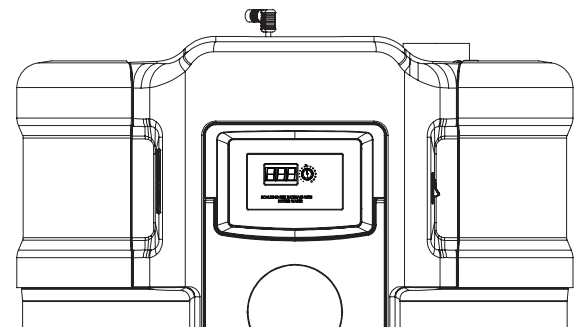

Top View

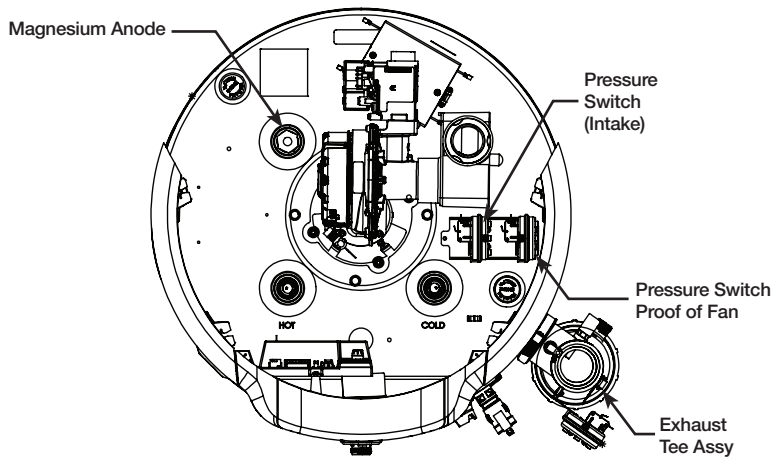

Back Iso View

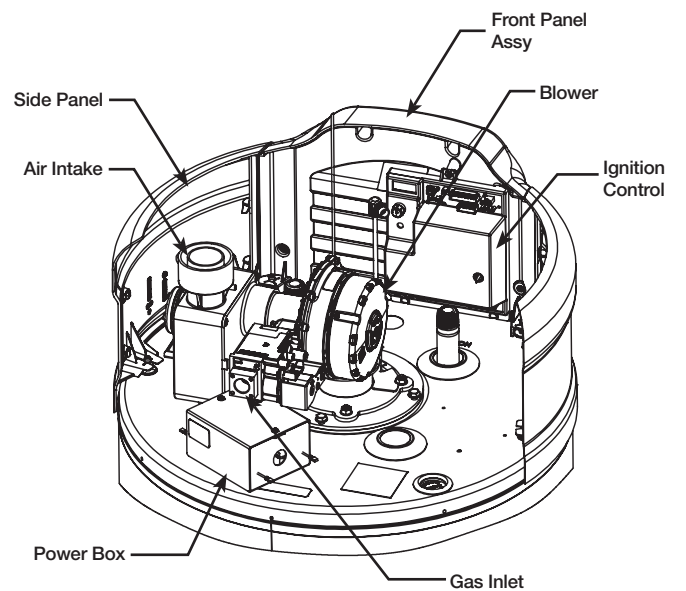

This water heater must be installed in accordance with these instructions, local codes, utility company requirements, and/or in the absence of local codes, use the latest edition of CAN / CSA B149 - Natural Gas and Propane Installation Code. A copy can be purchased from the Canadian Standards Association, 5060 Spectrum Way, Mississauga, Ontario L4W5N6.

Location

The water heater should not be located in an area where leakage from the tank or connections will result in damage to the area adjacent to the heater or to lower floors of the structure.

When such areas cannot be avoided it is recommended that a suitable drain pan, adequately drained, must be installed under the water heater.

The auxiliary drain pan installation **MUST** conform with local codes.

The water heater must be positioned in the drain pan as shown. Ensure that the condensate-tee is located inside the drain pan. The recommended minimum drain pan size of 28" diameter

DRAIN PAN



Drain pan kits are available from the store where the water heater was purchased, or any water heater distributor.

Make certain the floor underneath the water heater is strong enough to sufficiently support the weight of the water heater once it is filled with water.

NOTICE:

DO NOT allow the flammable vapor sensor to become submerged in water. Make sure the drain pan is properly drained.

This gas-fired water heater or any other appliance should not be installed in a space where liquids which give off flammable vapors are to be used or stored. Such liquids include gasoline, LP gas (butane or propane), paint or adhesives, thinners, solvents and/or combustible removers.

⚠️ WARNING:

Combustible construction refers to adjacent walls and ceilings and should not be confused with combustible or flammable products and materials. Combustible and/or flammable products and materials should never be stored in the vicinity of this or any gas appliance.

DO NOT obstruct or block the Flammable Vapor Sensor.

Because of natural air movement in a room or other enclosed space, flammable vapors can be carried some distance from where liquids which give off flammable vapors are to be used or stored. The open flame of the water heater's main burner can ignite these vapors creating a shut down condition which will not allow the water heater to ignite.

Rheem Water Heating FVIR certified gas water heaters can be installed on a residential garage floor without the use of an 18 in. (46 cm.) stand in accordance with CAN/CSA B149.1 - Natural Gas and Propane Installation Code for Canadian Installations, unless otherwise directed by State and Local code requirements. The water heater must be located so it is not subject to physical damage, for example, by moving vehicles, area flooding, etc.

IMPORTANT: **DO NOT** install the water heater in a location where it may be subjected to ambient temperatures exceeding 125°F (52°C).

- The water heater should be installed so as to minimize the length of plastic vent and combustion air-inlet pipe and the number of vent and combustion air-inlet connection fittings required.
- See Vent and Combustion Air-Inlet Section for vent system requirements.
- Hot water lines should be insulated to conserve water and energy.
- Protect the water heater and water lines from exposure to freezing temperatures.
- **DO NOT** install this water heater outdoors.
- Minimum clearances from combustable construction:

Front	Sides	Rear	Top
5 In. (12.7 cm)	0 In. (0 cm)	0 In. (0 cm)	15 In. (30.5 cm)

The Exhaust Tee located on the right front of the unit will require additional side clearance of approximately 2.75" from the water heater.

NOTICE:

For proper operation and maintenance, a minimum clearance of 1.5 inches (3.8 cm) must be provided from the combination temperature and pressure relief valve to any wall or object.

"Front" Clearance dimension is measured from the water heater jacket to the closet door.

"Top" clearance dimension is measured from the jacket top of the water heater to the ceiling.

INSTALLATION

If the water heater is to be installed directly on carpeting, the water heater shall be installed on a metal or wood panel extending beyond the full width and depth of the water heater by at least 3 in. (7.6 cm) in all directions or, if the water heater is to be installed in an alcove or closet, the entire floor must be covered by a wood or metal panel.

CORROSIVE ATMOSPHERES

The air in beauty shops, dry cleaning establishments, photo processing labs, and storage areas for liquid and powdered bleaches or swimming pool chemicals often contain halogenated hydrocarbons.

An air supply containing halogenated hydrocarbons may be safe to breathe, but when it passes through a gas flame corrosive elements are released that will shorten the life of any gas burning appliance.

Propellants from common spray cans or gas leaks from A/C and refrigeration equipment are highly corrosive after passing through a flame.

The water heater warranty is voided when failure of the heater is due to operation in a corrosive atmosphere.

THERMAL EXPANSION

Determine if a check valve exists in the inlet water line. It may have been installed in the cold water line as a separate back flow preventer, or it may be part of a pressure reducing valve, water meter or water softener. A check valve located in the cold water inlet line can cause what is referred to as a "closed water system". A cold water inlet line with no check valve or back flow prevention device is referred to as an "open" water system.

As water is heated, it expands in volume and creates an increase in the pressure within the water system. This action is referred to as "thermal expansion". In an "open" water system, expanding water, which exceeds the capacity of the water heater, flows back into the city main where the pressure is easily dissipated.

A "closed water system", however, prevents the expanding water from flowing back into the main supply line and the result of "thermal expansion" can create a rapid, and dangerous pressure increase in the water heater and system piping. This rapid pressure increase can quickly reach the safety setting of the relief valve, causing it to operate during each heating cycle. Thermal expansion, and the resulting rapid, repeated expansion and contraction of components in the water heater and piping system can cause premature failure of the relief valve and possibly the heater itself. Replacing the relief valve will not correct the problem!

The suggested method of controlling thermal expansion is to install an expansion tank in the cold water line between the water heater and the check valve. The expansion tank is designed with an air cushion built in that compresses as the system pressure increases,

thereby relieving the over pressure condition and eliminating the repeated operation of the relief valve. Other methods of controlling thermal expansion are also available. Contact your installing contractor, water supplier, or plumbing inspector for additional information regarding this subject.

WATER CONNECTIONS

Refer to illustration on page 11 for suggested typical installation. The installation of unions or flexible connectors is recommended on the hot and cold water connections so that the water heater may be easily disconnected for servicing if necessary. If flexible water connections are used, they must comply with the standard for flexible Water Connectors, ASME A112.18.6/CSA-B125.6. The HOT and COLD water connections are clearly marked on the water heater. Install a shutoff valve in the cold water line near the water heater.

IMPORTANT

All models are equipped with front and side panels, it is recommended that the hot and cold water piping have a minimum vertical height of 10 inches (25.4 cm) from the top of the water heater before transitioning into any elbow. This vertical height is needed in order to provide adequate clearance for Side Panel installation and removal.

To gain access to the hot and cold water connections the side panels need to be removed. The side panels are secured on the top of the water heater with fastening pegs (see illustration). Pull the side panels either outwards or upwards to release panels from pegs.

RELIEF VALVE

The pressure rating of the relief valve must not exceed 150 psi (1,034 kPa), the maximum working pressure of the water heater as marked on the rating plate.

The Btu/h rating of the relief valve must equal or exceed the Btu/h input of the water heater as marked on its rating plate.

Position the outlet of the relief valve above a suitable open drain to eliminate potential water damage. Piping used should be of a type approved for hot water distribution.

The discharge line must be no smaller than the outlet of the valve and must pitch downward from the valve to allow complete drainage (by gravity) of the relief valve and discharge line.

The end of the discharge line should not be threaded or concealed and should be protected from freezing. No valve of any type, restriction, or reducer coupling should be installed in the discharge line.

TO FILL THE WATER HEATER

Make certain that the drain valve is closed, then open the shut-off valve in the cold water supply line.

Open each hot water faucet slowly to allow the air to vent

INSTALLATION

from the water heater and piping.

A steady flow of water from the hot water faucet(s) indicates a full water heater.

DO NOT allow the flammable vapor sensor to become submerged in water.

GAS SUPPLY

The inlet gas pressure to the water heater must not exceed 10.5" wc (2.6 kPa) for Natural gas and 13.0" wc (3.2 kPa) for L.P. gas. The minimum inlet gas pressure (with main burner on) is shown on the rating plate. Check to see if high or low gas pressure is present and then contact the gas company for correction.

The branch gas supply line to the water heater should be clean properly sized steel pipe or other approved gas piping material.

A union or ANSI design certified semirigid or flexible gas appliance connector should be installed in the gas line close to the water heater. The National Fuel Gas Code (NFPA) mandates a manual gas shut off valve: See (NFPA) for complete instructions.

If flexible connectors are used, the maximum length shall not exceed 36 in. and must meet the requirements in ANSI Z21.24/CSA 6.10 - Connectors for Gas Appliances.

Compound used on the threaded joints of the gas piping must be of the type resistant to the action of LP gas. Use compound sparingly on male threads only.

Where a sediment trap is not incorporated as part of the appliance, a sediment trap shall be installed downstream of the equipment shutoff valve as close to the inlet of the appliance as practical at the time of the appliance installation. The sediment trap shall be either a tee fitting with a capped nipple in the bottom outlet or other device recognized as an effective sediment trap. See figure.

DO NOT use excessive force (20Ft. Lbs.) in tightening the pipe joint at the gas control (thermostat) inlet, particularly if teflon pipe compound is used, as the valve body may be damaged.

For purposes of input adjustment, the minimum inlet gas pressure (with main burner on) is shown on the water heater rating plate. If high or low gas pressure are present, contact your gas supplier for correction.

A ground joint union and manual shutoff valve should be installed in the gas line near the water heater so that the burner assembly may be easily removed. The shut-off valve must be readily accessible for turning on or off.

LEAK TESTING

The water heater and its gas connections **MUST** be leak tested at normal operating pressure before it is placed in operation. Turn **ON** the manual gas shut-off valve near the water heater. Use a soapy water solution to test

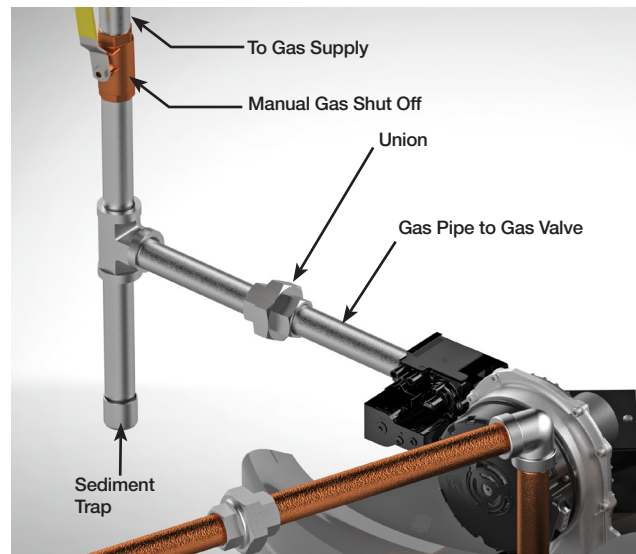

for gas leaks at all connections and fittings. Bubbles indicate a gas leak that must be corrected. The water heater factory connections to the gas valve should also be leak tested after placing the water heater in operation.

⚠ WARNING:

NEVER use open flame to test for gas leaks, as bodily injury or property damage could result.

PRESSURE TESTING THE GAS SUPPLY SYSTEM

The water heater and its individual gas shut-off valve **MUST** be disconnected from the gas supply piping system during any high pressure testing of that system at pressures in excess of 1/2 psi (14" WC. 3.5 kPa).

The water heater **MUST** be isolated from the gas piping system by closing the manual gas shut-off valve during any pressure testing of the gas supply piping at pressures equal to or less than 1/2 psi (14" WC / 3.5 kPa).

CONDENSATE

The exhaust elbow/condensate trap is shipped pre-installed with the heater. Pour the neutralizer into the exhaust tee before vent pipe installation. Make sure that the neutralizer is at the bottom as shown in the figure on next page.

This is a condensing high efficiency appliance and has a condensate removal system. The exhaust tee incorporates a condensate trap and must be filled with water before operating the water heater. Pour about 1 cup of water into the exhaust tee.

This water heater generates condensate and requires a drain to be located in close proximity to allow condensate to drain safely. The drain line and fittings should be installed per installation instructions.

Be sure the condensate runs freely to the drain and does not accumulate in the condensate trap or the condensate

INSTALLATION

CONDENSATE NEUTRALIZER



CONDENSATE DRAIN

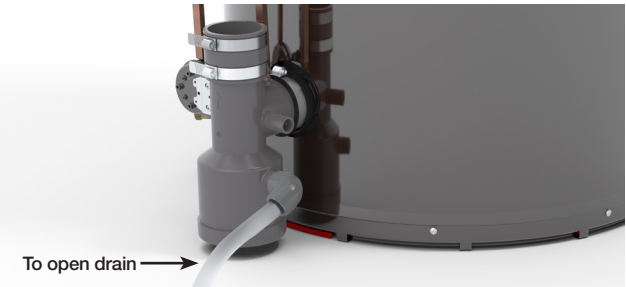

line. In cold climates, precautions may need to be taken to ensure that the condensate drain lines do not freeze. A water proof heat tape may be used to prevent freezing of condensate lines.

- Condensate is mildly acidic and should be collected and disposed per local codes. Certain local codes require condensate to be neutralized before it is disposed. This water heater comes with a pre-packaged neutralizer bag. Pour the neutralizer in the exhaust-tee prior to installing vent pipes. Make sure the neutralizer is at the bottom of the exhaust-tee.
- Use only PVC, CPVC pipe or flexible tubing suitable for use with flue condensate as drain line. If flexible tubing is used ensure that there are no bends or twists and has gradual slope to condensate drain.
- The drain line (along its entire length) must be at least the same diameter as the drain of the condensate trap (1/2").
- The drain line must be short as possible and have a downward slope towards the condensate drain. If suitable slope is not provided, the drain line can get blocked and will cause improper operation of the water heater. If a downward slope cannot be provided, a condensate pump should be used to pump condensate to a suitable drain.
- The end of the drain line should be open to the atmosphere. The end should not be under water.
- DO NOT connect the drain line directly to the sewer drain.
- DO NOT connect the drain line with drains from other appliances.
- DO NOT drain condensate into the water heater drain pan.
- DO NOT drain condensate over public way, walkway or other areas where it will create slippery condition, which could lead to personal injury.

HIGH ALTITUDE

Input rating of this water heater is based on sea level operation. At higher elevations the actual input rate may be lower than the value listed on the rating label due to the derating of Natural Gas and LP Gas.

Natural Gas models with sea level rated input rates of 50,000 BTUH require adjustments on touch screen display for high altitude installations above 2000 feet. These adjustments are activated only on models that require high altitude adjustments

Refer to vent length chart in 'Venting and Air Intake' section for appropriate elevations, vent sizes, and lengths.

⚠ WARNING:

Failure to install a water heater suitable for the altitude at the location it is intended to serve, can result in improper operation of the appliance resulting in property damage and/or producing carbon monoxide gas, which could result in personal injury, or death.

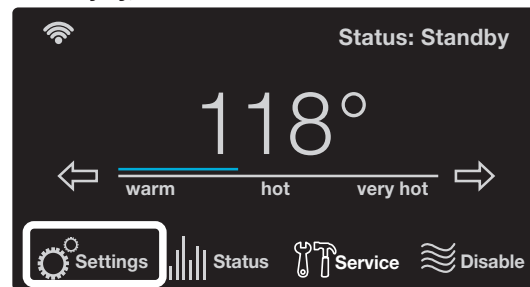

1. MAIN SCREEN

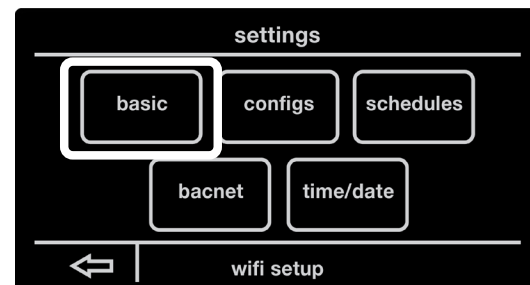

2. SETTINGS SCREEN

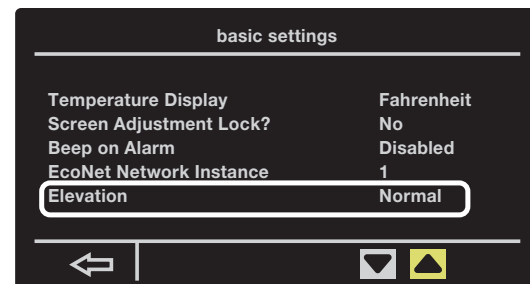

3. BASIC SETTINGS SCREEN: ELEVATION NORMAL

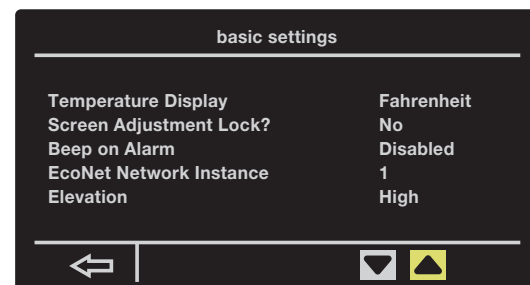

4. BASIC SETTINGS SCREEN: ELEVATION HIGH

INSTALLATION

WIRING

A correct polarity 120V 50/60 Hz power supply with suitable disconnect means, must be connected to the black and white leads provided. The maximum current draw by these models is 7 Amps. The water heater, when installed, must be electrically grounded in accordance with local codes or, in the absence of local codes, with the National Electrical Code, ANSI/NFPA 70 in the United States, or CSA C22.1 Electrical Code, in Canada. Improper grounding or polarity may result in abnormal operation of the unit.

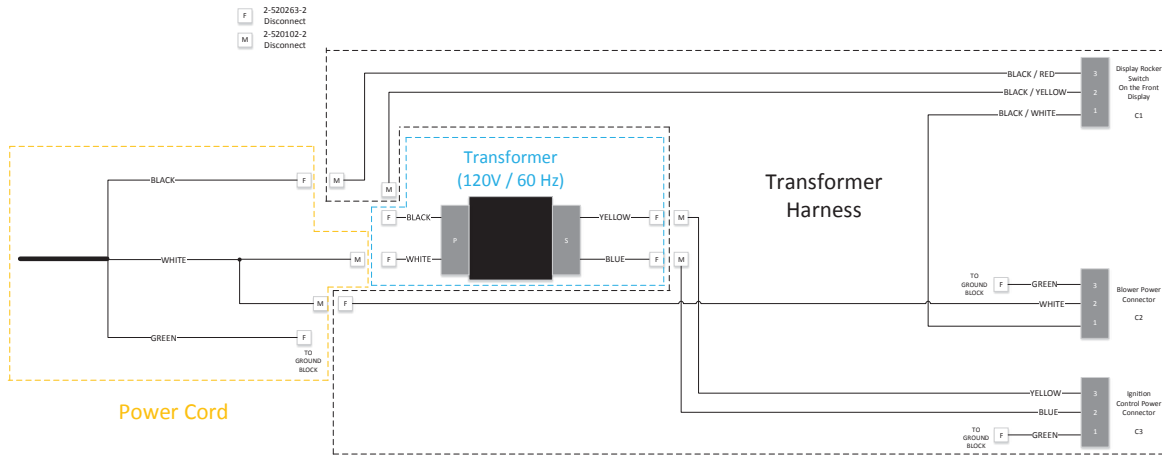

TYPICAL INSTALLATION

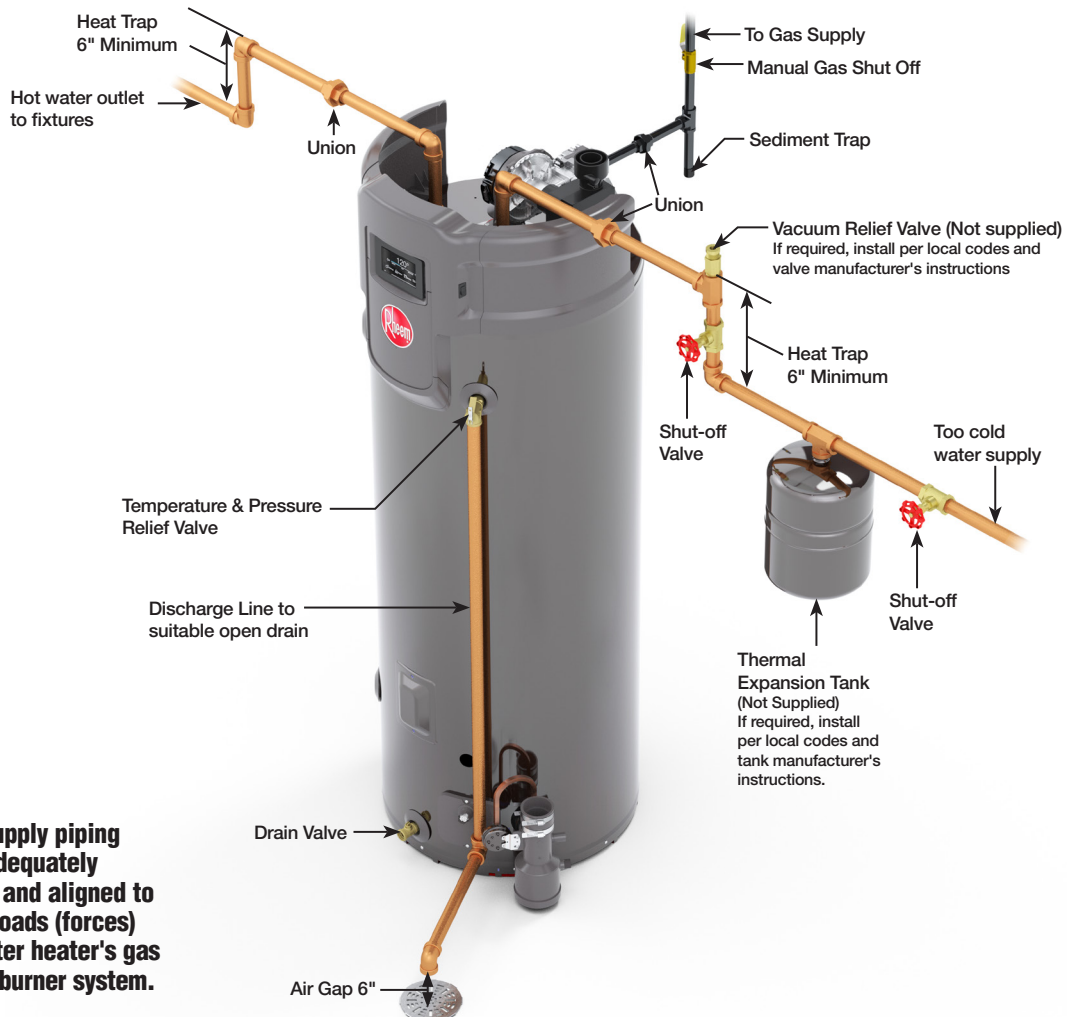

NOTES:

The gas supply piping must be adequately supported and aligned to minimize loads (forces) on the water heater's gas valve and burner system.

INSTALLATION

TYPICAL PIPING DIAGRAM FOR COMBINATION POTABLE/SPACE HEATING INSTALLATION

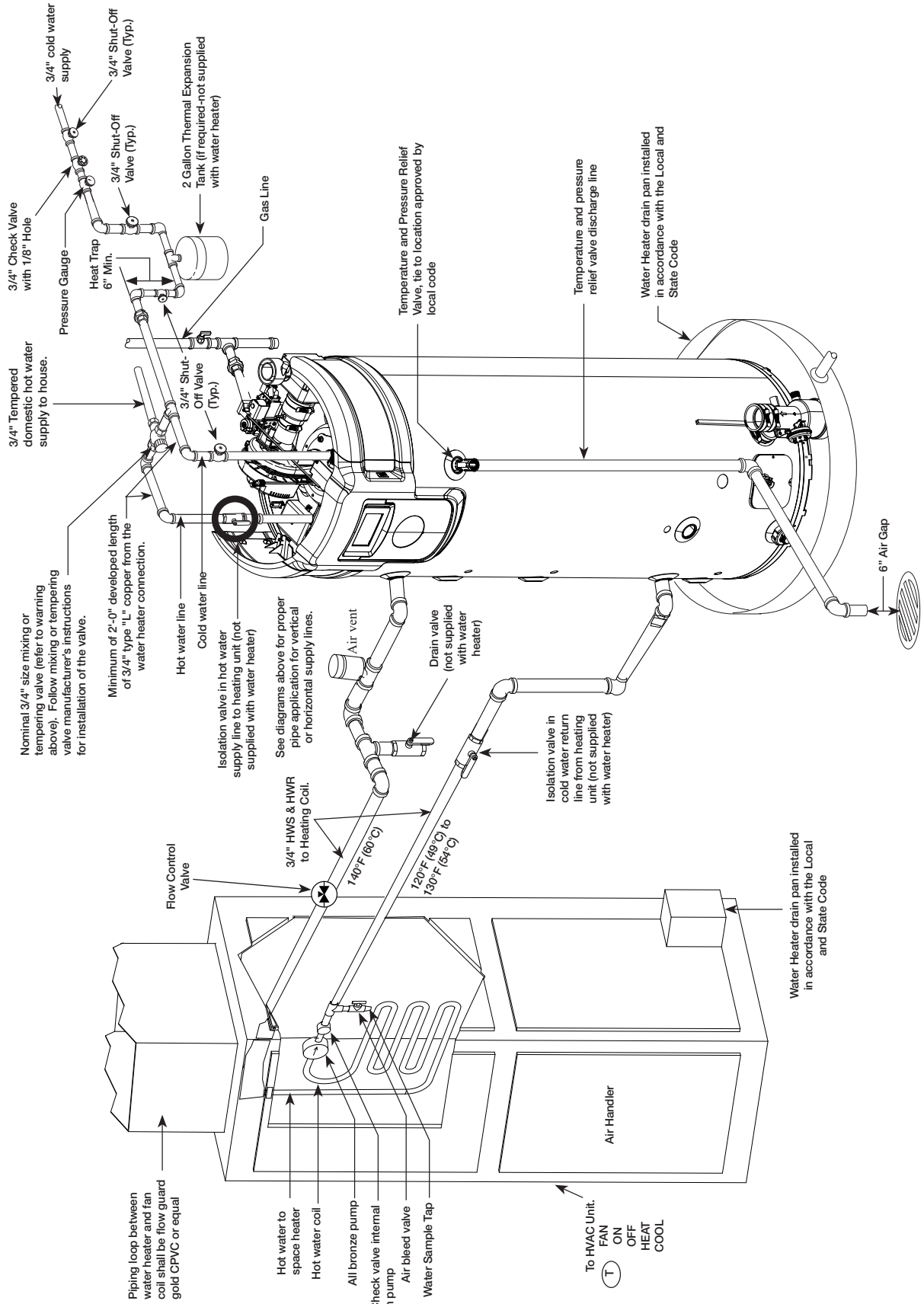

VENT AND COMBUSTION AIR INLET

NOTE: This unit can be vented either as a direct vent or power vent configuration.

⚠ WARNING:

DO NOT connect this water heater to an existing vent or chimney; it must be vented separately from all other appliances, using only approved venting materials.

⚠ WARNING:

Failure to properly vent the water heater to the outdoors as outlined above and in the following section can result in unsafe operation of the water heater causing bodily injury, explosion, fire or death.

⚠ DANGER:

To avoid the risk of fire, explosion, or asphyxiation from carbon monoxide, **NEVER** operate the water heater unless it is properly vented and the vent and combustion air inlet systems are properly installed as detailed in the "Vent and Combustion Air-Inlet" section of this manual.

The vent and combustion air inlet pipes must overlap a minimum of 1/2 in. (1.3 cm) at each joint. It is important that the vent and combustion air inlet pipes engage fully into any pipe fitting and be kept in that position until the adhesive has fully cured. **DO NOT** drill or punch holes in the plastic pipe or fittings.

NOTICE:

This unit can be vented using only the below recommended pipe material. Use only 2, 3, or 4 inch diameter pipe.

Refer to local codes for restrictions on the use of PVC, CPVC, PP or ABS pipe and fittings. All exhaust venting materials for products installed in Canada must meet ULC-S636.

PVC (DWV, ASTM-D2665 or CSA B181.2)

PVC (Schedule 40, ASTM-D1785 or CSA B137.3)

PVC (SDR Series, ASTM-D2241 or CSA B137.3)

CPVC (CPVC 4120, ASTM-D2846 or CSA B137.6)

CPVC (Schedule 40, ASTM-F441 or CSA B137.3)

CPVC (SDR Series, ASTM-F442)

Polypropylene

INSTALLATION

NOTICE:

Use of PVC cellular core (ASTM-F891), ABS Schedule 40, DWV cellular core (ASTM -F628), or Radel® (polyphenylsulfone) in non-metallic venting systems is prohibited.

The unit may be vented horizontally through a wall or vertically through the roof. Pipe runs must be adequately supported along both vertical and horizontal runs. Maximum unsupported span is recommended to be no more than 3'. It is imperative that the first hanger be located on the horizontal run immediately adjacent to the first 90-degree elbow from the vertical rise or at the blower outlet. The support method used should isolate the vent pipe from floor joists or other structural members to help prevent the transmission of noise and vibration. DO NOT support, pin, or otherwise secure the venting system in a way that restricts the normal thermal expansion and contraction of the chosen venting material.

If the water heater is being installed as a replacement for an existing power vented or power direct vented water heater, a thorough inspection of the existing venting system must be performed prior to any installation work. Verify that the correct materials, as detailed above, have been used and that the minimum or maximum vent length and terminal locations, as detailed in this manual, have been met. Carefully inspect the entire venting system for any signs of cracks or fractures, particularly at the joints between elbows or other fittings and the straight runs of vent pipe. Check the system for signs of sagging or other stresses in the joints as a result of misalignment of any components in the system. If any of these conditions are found, they must be corrected in accordance with the venting instructions in this manual before completing the installation and putting the water heater into service.

VENT PIPE CONNECTION LOCATIONS

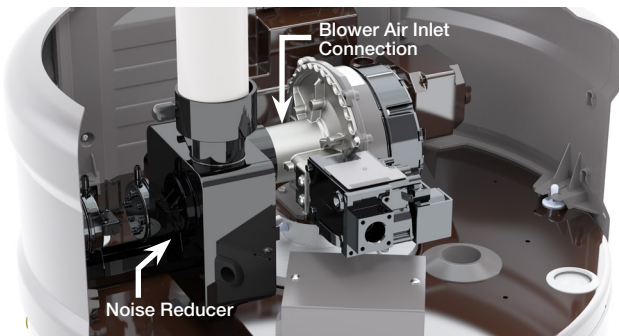

VENT PIPE CONNECTION

Refer to "Vent Pipe Connection Locations" Figure, for connecting the vent pipe to the water heater. These models can be vented either as a direct vent or as a power vent water heater.

NOTICE:

If the unit is installed as a power vent water heater, the vent terminal with screen must still be installed on the inlet air side.

Before starting the vent installation, careful planning of the routing and termination of vent and air inlet pipes can reduce installation times. The length of the vent and air inlet pipes should be kept to a minimum. Refer to the venting charts in Table 1 for the pipe sizes and the total equivalent length of pipe that can be used. DO NOT exceed the equivalent length of pipe in the charts.

Depending on the size of pipe selected for venting the water heater, it may be necessary to use a fitting for stepping up to connect to the water heater. DO NOT step down pipe size below the 2" pipe size. All models are shipped with 2" vent terminals with screen. If another size of pipe is used for venting the unit, the proper vent terminal must be installed.

When the unit is vented as a direct vent, through a side wall, the vent terminals must be on the same exterior wall mounted horizontally and maintain a minimum distance between the centers of 15" (38.1 cm).

JOINING PIPES AND FITTINGS

All pipe, fittings, solvent cement, primers, and procedures, must conform to American National Standards Institute and American Society for Testing and Materials (ANSI/ASTM) standards in the U.S. For Canada, all pipe, fittings, solvent cement, primers, and procedures must conform to ULC-S636 and vent manufacture specifications.

CEMENTING JOINTS

NOTICE:

All pipe, fittings, solvent cement, primers and procedures must conform to American National Standards Institute and American Society for Testing and Materials (ANSI/ASTM) standards.

All joints in the vent piping must be properly sealed. Use of the following material is recommended:

PVC materials should use ASTM D-2564 grade cement.

CPVC materials should use ASTM F-493 grade cement.

ABS materials should use ASTM D-2235 grade cement.

(ABS is not allowed in Canada)

Cleaner-Primer and Medium Body Solvent Cement

1. Cut the pipe end square, removing all jagged edges and burrs. Chamfer the end of the pipe, and, then, clean the fitting socket and pipe joint area to remove all dirt, grease, and moisture.
2. After checking pipe and socket for proper fit, wipe the socket and pipe with cleaner-primer. Apply a liberal coat of primer to the inside surface of the socket and the outside of the pipe. DO NOT allow the primer to dry before applying the cement.
3. Apply a thin coat of cement evenly in the socket. Quickly apply a heavy coat to the pipe end. Insert the pipe into the fitting with a slight twisting motion until it bottoms out.

NOTICE:

Cement must be fluid; if not, re-coat.

4. Hold the pipe fitting for 30 seconds to prevent the tapered socket from pushing the pipe out of the fitting.
5. Wipe all excess cement from the joint with a rag. Allow 15 minutes for drying before handling. Cure time will vary according to fit, temperature, and humidity.

NOTICE:

Stir the solvent cement frequently while using. Use a natural bristle brush or the dauber supplied with the can. The proper brush size is one inch.

DANGER OF FIRE OR BODILY INJURY

Solvent cements and primers are highly flammable. Provide adequate ventilation and do not assemble near a heat source or open flame. **DO NOT** smoke. Avoid skin or eye contact. Observe all cautions and warnings on material containers.

FOR PROPER INSTALLATION

⚠ CAUTIONS:

- **DO NOT** use solvent cement that has become curdled, lumpy or thickened.
- **DO NOT** thin solvent cement. Observe shelf precautions printed on the containers.
- For applications below 32°F (0°C), use only low temperature type solvent cement.
- Appropriate solvent and cleaner must be used for the type of vent pipe used (PVC, CPVC, PP, or ABS).

Additional Fitting Considerations

EXAMPLES OF ELBOWS:

It is recommended to use only standard and/or long sweep elbows. See examples as shown.

10 Feet Equivalent Length

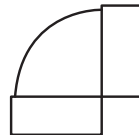

Short Sweep 90° Elbow

8 Feet Equivalent Length

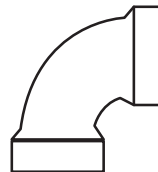

Standard 90° Elbow

5 Feet Equivalent Length

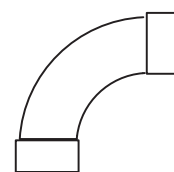

Long Sweep 90° Elbow

Minimum and Maximum Vent Lengths

Important information for all installations:

- 1) The minimum required venting is what is required to safely extend the inlet and outlet vent pipes outside of the building.
- 2) Each 90° elbow (standard or long sweep elbow) reduces the equivalent vent length as shown.
- 3) Each 45° elbow reduces the equivalent vent length by 2 1/2 feet (0.8m).
- 4) **DO NOT** mix pipe sizes for venting these models, use only one size of pipe for all venting.
- 5) All vent terminations (horizontal or vertical) should be a minimum of 24 inches (61cm) and a maximum of 36 inches (91 cm) apart, as measured from center to center of terminals.

Exceeding the maximum equivalent vent lengths may cause the water heater to malfunction or cause a lock-out condition.

Feet	to	Meters
20		6.1
50		15.2
60		18.3
70		21.3
80		24.4
100		30.5
120		36.6
130		39.6
170		51.8

INSTALLATION

Table 1 Residential Equivalent Vent Lengths

40G-50K AND 50G-50K; POWER VENT CONFIGURATION; (RIGID PIPE)				40G-50K AND 50G-50K; POWER DIRECT VENT CONFIGURATION; (RIGID PIPE)				Terminations
Elevation (Feet)	Vent Size (Inches)	Vent Length (Feet)		Nat Max Eq. Vent		LP Max Eq. Vent		
		Nat Max Eq. Vent	LP Max Vent	Intake	Exhaust	Intake	Exhaust	
0-2000	2"	50'	50'	50'	50'	50'	50'	2" AND 3" 90° ELBOWS, 2", 3" AND 4" CONCENTRIC AND 2" AND 3" PANCAKE
	3"	140'	140'	140'	140'	140'	140'	
	4"	140'	140'	140'	140'	140'	140'	
2000-5400	2"	50'	40'	50'	50'	40'	40'	
	3"	140'	110'	140'	140'	110'	110'	
	4"	140'	110'	140'	140'	110'	110'	
5400-7800	2"	50'	20'	50'	50'	10'	20'	
	3"	140'	110'	140'	140'	110'	110'	
	4"	140'	110'	140'	140'	110'	110'	
7800-10,100	2"	50'	NOT APPLICABLE	50'	50'	NOT APPLICABLE	NOT APPLICABLE	
	3"	140'	NOT APPLICABLE	140'	140'	NOT APPLICABLE	NOT APPLICABLE	
	4"	140'	NOT APPLICABLE	140'	140'	NOT APPLICABLE	NOT APPLICABLE	

*MINIMUM INTAKE AIR AND EXHAUST VENT: 10' EQUIVALENT LENGTH

NATURAL GAS MODELS CAN BE INSTALLED IN HIGH ALTITUDE LOCATIONS WITH DISPLAY CONTROL SETTING CHANGES AS SHOWN IN HIGH ALTITUDE SECTION. APPLIES ONLY TO TOUCH SCREEN DISPLAY MODELS

++LP GAS MODELS HAVE UNIQUE HIGH ALTITUDE MODEL NUMBERS. THEY ARE FACTORY SET FOR HIGH ALTITUDE OPERATION. HIGH ALTITUDE MODELS HAVE A 'H' DESIGNATION AT THE END OF THE MODEL NUMBER. REFER TO RATING PLATE FOR MODEL NUMBER.

50G-76K, 50G-100K; POWER VENT CONFIGURATION; (RIGID PIPE)				50G-76K, 50G-100K; POWER DIRECT VENT CONFIGURATION; (RIGID PIPE)				Terminations
Elevation (Feet)	Vent Size (Inches)	Vent Length (Feet)		Nat Max Eq. Vent		LP Max Eq. Vent		
		Nat Max Eq. Vent	LP Max Vent	Intake	Exhaust	Intake	Exhaust	
0-10,100	2"	40'	40'	40'	40'	40'	40'	2" AND 3" 90° ELBOWS, 2", 3" AND 4" CONCENTRIC AND 2" AND 3" PANCAKE
	3"	140'	140'	140'	140'	140'	140'	
	4"	140'	140'	140'	140'	140'	140'	

MINIMUM INTAKE AIR AND EXHAUST VENT: 10' EQUIVALENT LENGTH

Note: Vent pipe size should not be mixed for venting these water heaters. Use same diameter pipe for all venting of the unit.

All power direct models can use 2 in. concentric venting only as listed in the above chart.

2 inch concentric vent can only be used with 2 inch rigid piping.

DO NOT mismatch concentric vent terminations with different rigid piping as it may cause the heater to malfunction or cause a lock-out condition unless specifically mentioned.

3" Concentric vent may be used with 3" and 4" venting.

Flexible Polypropylene pipe (ft)				
Pipe Size (IN.)	2"		3"	
	Intake	Exhaust	Intake	Exhaust
Max PV	0	30' (13m)	0	30' (13m)

Follow manufacturers instructions for installation of flex vents.

Direct Vent Installation

Check to make sure flue gases **DO NOT** recirculate into the air intake terminal when using direct venting. If the water heater is having service issues, flue recirculation may be a contributing factor.

Even when the minimum vent terminal separation distances are followed, recirculation may still occur, depending upon the location outside the building, the distance from other buildings, proximity to corners, weather conditions, wind patterns, and snow depth.

Periodically check to make sure that flue recirculation is not occurring. Signs of flue gas recirculation include frosted or frozen intake terminals, condensate in the intake terminal and venting system, oxidation, or white chalk material on the flame sensor or igniter shield. Correction to flue recirculation may involve angling the intake away from the exhaust terminal, increasing the distance between them, or using inside air for combustion. Check to be sure the intake and exhaust terminals are not obstructed, especially during periods of below freezing weather.

All intake and exhaust venting components must have the same diameter size. **DO NOT** use a different size on the intake and exhaust venting.

Be sure the condensate runs freely to a drain and does not accumulate inside the water heater. In cold climates, precautions may need to be taken to insure that the condensate drain does not freeze. Make sure the condensate trap or drain loop is installed to prevent flue gases from being discharged into the room. Refer to the "Venting" section of this manual for complete instructions on venting and condensate drainage.

Stress levels in the pipe and fittings can be significantly increased by improper installation. If rigid pipe clamps are used to hold the pipe in place, or if the pipe cannot move freely through a wall penetration, the pipe may be directly stressed, or high thermal stresses may be formed when the pipe heats up and expands. Install accordingly to minimize such stresses. Follow the below procedure to vent through the wall.

1. Cut two holes for the pipe to pass through. The hole diameter should be 2.5" (6.4 cm) for 2" pipe, 3.5" (8.9 cm) for 3" pipe. Vent terminals must maintain a horizontal distance apart in the range of 24" min. (61 cm).
2. Use the proper PVC cement (primer and adhesive) to secure the exhaust vent and air intake terminals provided with the water heater to the plastic pipes. The distance between the back edge of the exhaust vent terminal and the exterior wall must be 6 inches (12.7 cm) more for the exhaust vent terminal than the air intake terminal. Use the proper cement or sealant and assembly procedures to secure the vent connector joints between the terminal and the blower outlet. Provide support brackets every 3 feet (.91 m) of horizontal vent beyond the intake terminal.

INSTALLATION

TYPICAL HORIZONTAL VENT INSTALLATION

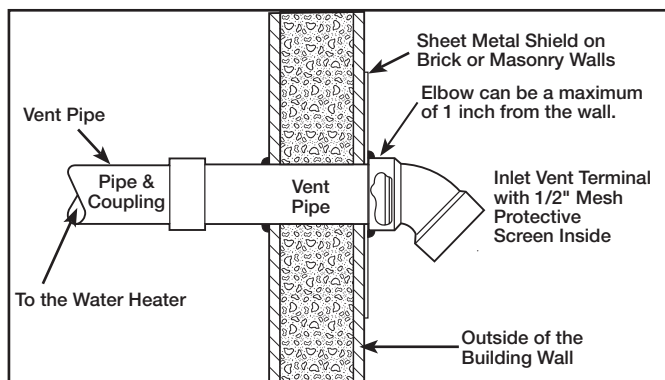
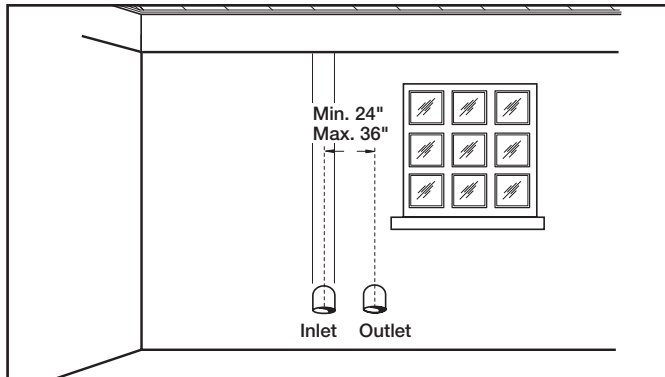

Additional Considerations (in the following pages)

DO NOT install vent terminals under any patio or deck.

To help prevent moisture from freezing on walls and under eaves, **DO NOT** locate outlet vent terminal on the side of your home with prevailing winter winds.

DO NOT terminate vent pipe directly on brick or masonry surfaces. Use a rust-resistant sheet metal backing plate behind vent. (See Figure above.)

DO NOT locate vent terminal too close to shrubbery, since flue gases may damage them.

Caulk all cracks, seams and joints within 6 feet (1.83 m) of vent terminal.

All painted surfaces should be primed to lessen the chance of physical damage. Painted surfaces will require maintenance.

Make sure that all vent pipes exposed to cold conditions (attics, crawl spaces, etc.) have the proper slope and support to keep moisture from accumulating in the vent pipes. **NOTE:** Insulating of non-metallic vent materials is prohibited.

This water heater requires its own separate venting system. **DO NOT** connect the exhaust vent to an existing vent pipe or chimney.

Moisture in the flue gas will condense as it leaves the vent terminal. In cold weather this condensate can freeze on the exterior wall, under the eaves, and on surrounding objects. Some discoloration to the exterior of the building is to be expected; however, improper location or installation can result

in severe damage to the structure or exterior finish of the building. In locations with extended amounts of time with temperatures under 40°F. (4°C.) and/or prevailing wind toward the outlet vent, make sure that the outlet vent terminal is at least 2 feet (0.61 m) away from anything that can be damaged by the condensate.

HORIZONTAL VENT INSTALLATION

Once the vent terminal location has been determined, make a hole through the exterior wall to accommodate the vent pipe. The vent pipe must exit the exterior wall horizontally only (See Typical Horizontal Vent Installation Figure on this page).

Insert a small length of vent pipe through the wall, and connect the coupling as shown in Typical Horizontal Vent Installation Figure. Connect the vent terminal as shown to the vent pipe on the exterior of the building. Seal any opening around the vent pipe or fittings with mortar or silicone caulk as shown in Typical Horizontal Vent Installation Figure.

Complete the rest of the vent pipe installation to the water heater's vent connector fitting on the blower outlet. If necessary, support the horizontal run of pipe as previously mentioned.

VERTICAL VENT TERMINAL LOCATION

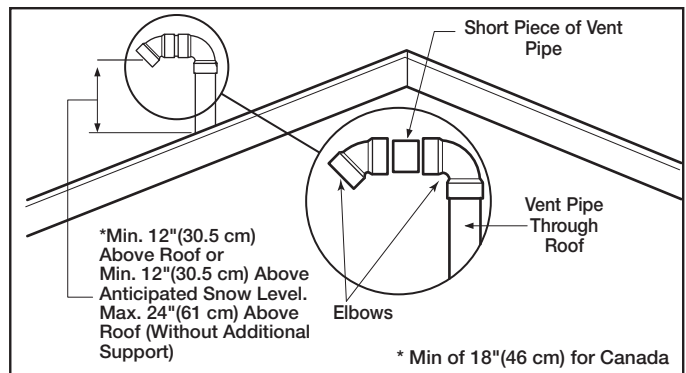

VERTICAL VENT INSTALLATION

Once the vent terminal location has been determined, make a hole through the roof and interior ceiling to accommodate the vent pipe. Complete the vent pipe installation to the water heater's vent connector fitting on the blower outlet. Support vertical or horizontal runs as previously mentioned.

Install adequate flashing where the vent pipe passes through the roof. Determine the vent terminal height and cut the vent pipe accordingly. Refer to Vertical Vent Terminal Location Figure for the proper vent terminal height. Connect the vent elbow onto the vertical pipe through the roof. Connect a short piece of vent pipe (approximately 3" (7.6 cm) long) to the elbow, and, then, join the vent terminal to the short piece of vent pipe.

VERTICAL VENT TERMINAL LOCATION

The location of the vertical vent terminal depends on the following considerations (see Vertical Vent Terminal Location Figure on previous page):

1. Minimum 12 in. (30.5 cm) above roof. Minimum 18" above roofline for Canada
2. Minimum 12 in. (30.5 cm) above anticipated snow level.
3. Maximum 24 in. (61cm) above roof level without additional support for vent.
4. Four (4) ft. (1.22 m) from any gable, dormer or other roof structure with building interior access (i.e., vent, window, etc.).
5. Ten (10) ft. (3.05m) from any forced air inlet to the building. Any fresh or make-up air inlet such as a dryer or furnace area is considered to be a forced air inlet.
6. Maintain a minimum horizontal distance of 12 in. (30.5 cm) between the vent and combustion air-inlet terminal centerlines.
7. Maintain a minimum distance from the vent and the combustion air-inlet terminals of not less than 12 in. (30.5 cm) above grade or average snowfall, whichever is greater.

INSTALLATION

Direct Vent Terminal Clearances

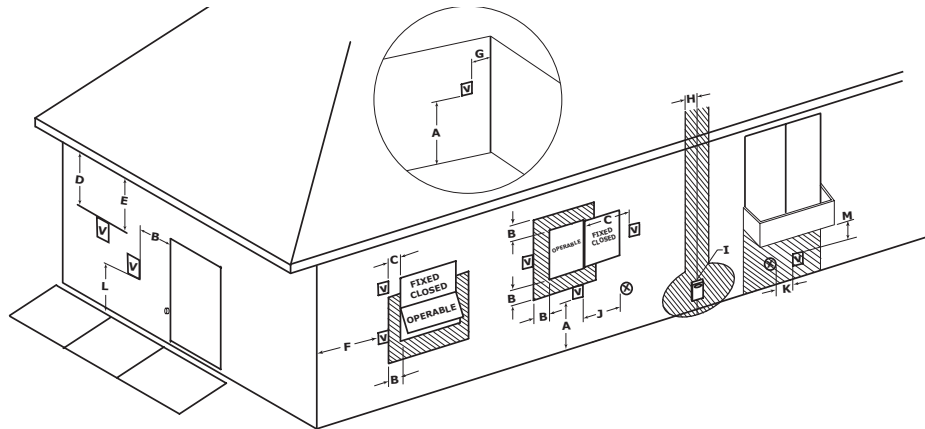

V VENT TERMINAL
 X AIR SUPPLY INLET
 AREA WHERE TERMINAL IS NOT PERMITTED

HORIZONTAL VENT TERMINAL LOCATION FOR POWER DIRECT VENT

The following information should be used for determining the proper location of the vent terminal for direct vent water heaters.

Canadian Installations ¹

US Installations ²

	Canadian Installations ¹	US Installations ²
A= Clearance above grade, veranda, porch, deck or balcony.	12 inches (30 cm)	12 inches (30 cm)
B= Clearance to window or door that may be opened.	<ul style="list-style-type: none"> 6 in (15 cm) for appliances < 10,000 Btuh (3 kW), 9 in (23 cm) for appliances > 10,000 Btuh (3 kW) and < 50,000 Btuh (15 kW), 12 in (30 cm) for appliances > 50,000 Btuh (15 kW) 	<ul style="list-style-type: none"> 6 in (15 cm) for appliances < 10,000 Btuh (3 kW), 9 in (23 cm) for appliances > 10,000 Btuh (3 kW) and < 100,000 Btuh (30 kW), 36 in (91 cm) for appliances > 100,000 Btuh (30 kW)
C= Clearance to permanently closed window.	0 in (0 cm)	0 in (0 cm)
D= Vertical Clearance to ventilated soffit located above the terminal within a horizontal distance of 2 feet (61 cm) from the center line of the terminal.	12 in (30 cm)	12 in (30 cm)
E= Clearance to unventilated soffit.	12 in (30 cm)	12 in (30 cm)
F= Clearance to outside corner.	24 in (61 cm)	24 in (61 cm)
G= Clearance to inside corner.	18 in (46 cm)	18 in (46 cm)
H = Clearance to each side of center line extended meter/regulator assembly. above	3 ft (91 cm) within a height of 15 ft (4.6 m)	3 ft (91 cm) within a height of 15 ft (4.6 m)
I = Clearance to service regulator vent outlet.	3 ft (91 cm)	3 ft (91 cm)
J = Clearance to nonmechanical air supply inlet to the building or the combustion air inlet of any other appliance..	<ul style="list-style-type: none"> 6 in (15 cm) for appliances < 10,000 Btuh (3 kW), 9 in (23 cm) for appliances > 10,000 Btuh (3 kW) and < 100,000 Btuh (30 kW), 36 in (91 cm) for appliances > 100,000 Btuh (30 kW) 	<ul style="list-style-type: none"> 6 in (15 cm) for appliances < 10,000 Btuh (3 kW), 9 in (23 cm) for appliances > 10,000 Btuh (3 kW) and < 50,000 Btuh (15 kW), 12 in (30 cm) for appliances > 50,000 Btuh (15 kW)
K = Clearance to mechanical air supply inlet.	6 ft (1.83 m)	3 ft (91 cm) above if within 10 ft (3 m) horizontally
L = Clearance above paved side walk or paved driveway located on public property.	7 ft (2.13 m)	7 ft (2.13 m) for mechanical draft system (Category I appliances); vents for Category II and IV appliances cannot be located above public walkways or other areas where condensate or vapor can cause a nuisance or hazard
M = Clearance under veranda, porch, deck or balcony.	12 in (30 cm) ‡	12 in (30 cm)*

¹ In accordance with the current CSA B149.1, Natural Gas and Propane Installation Code

² In accordance with the current ANSI Z223.1/ NFPA 54 National Fuel Gas Code.

‡ Permitted only if veranda, porch, deck, or balcony is fully open on a minimum of two sides beneath the floor.

* Permitted only if veranda porch, deck, or balcony is fully open on a minimum of two sides beneath the floor.

INSTALLATION

- **DO NOT** terminate near soffit vents or crawl space or other area where condensate or vapor could create a nuisance hazard or cause property damage.
- **DO NOT** locate the exhaust vent terminal where condensate or vapor could cause damage or could be detrimental to the operation of regulators, relief valves, or other equipment.
- **DO NOT** locate the exhaust vent terminal over public area or walkways where condensate or vapor can cause nuisance or hazard.
- **DO NOT** locate the vent terminal in proximity to plants/shrubs.

VENT INSTALLATION – Before proceeding, make certain you understand the procedure and cautions covered in the section “Joining Pipes and Fittings.”

POWER VENT INSTALLATION – Power venting is where the indoor air is used and the exhaust is vented to the outside. Venting may be run horizontally through an outside wall or vertically through a roof through using either 2" (5.1 cm), 3" (7.6 cm), 4" (10.2 cm) diameter PVC, ABS or CPVC. This water heater is supplied with a screened intake elbow and exhaust coupling referred to as the air intake terminal and the exhaust vent terminal.

NOTE: Flexible PP vent kit is available for Power Vent configurations, in 2" and 3" diameters. These kits should be used for vertical venting only.

NOTICE:

Use of PVC cellular core (ASTM-F891), ABS Schedule 40 DWV, cellular core (ASTM –F628), or Radel® (polyphenylsulfone) in non-metallic venting systems is prohibited.

In a horizontal application, it is important that condensate not be allowed to buildup in the exhaust vent pipe. To prevent this from happening, the pipe should be installed with a slight upward slope of ¼" per foot. The vent system must be supported every 5 feet of vertical run and every 3 feet of horizontal run of vent pipe length.

Failure to properly support the vent piping with hangers and clamps may result in damage to the water heater or venting system.

INSTALLATION

Power Vent Terminal Clearances

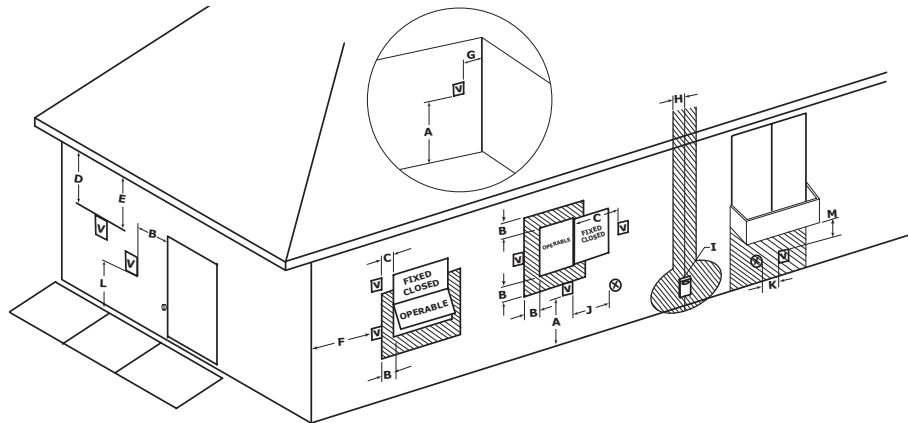

✓ VENT TERMINAL
 X AIR SUPPLY INLET
 AREA WHERE TERMINAL IS NOT PERMITTED
HORIZONTAL VENT TERMINAL LOCATION FOR POWER VENT

The following information should be used for determining the proper location of the vent terminal for direct vent water heaters.

	Canadian Installations ¹	US Installations ²
A= Clearance above grade, veranda, porch, deck or balcony.	12 inches (30 cm)	12 inches (30 cm)
B= Clearance to window or door that may be opened.	6 inches (15 cm) for appliances ≤ 10,000 Btuh (3 kW), 12 inches (30 cm) for appliances > 10,000 Btuh (3kW) and ≤ 100,000 Btuh (30kW), 36 inches (91 cm) for appliances > 100,000 Btuh (30kW).	4 feet (1.2 m) below or to side of opening; 1 foot (300 mm) above opening.
C= Clearance to permanently closed window.	0 in (0 cm)	0 in (0 cm)
D= Vertical Clearance to ventilated soffit located above the terminal within a horizontal distance of 2 feet (61 cm) from the center line of the terminal.	12 in (30 cm)	12 in (30 cm)
E= Clearance to unventilated soffit.	12 in (30 cm)	12 in (30 cm)
F= Clearance to outside corner.	24 in (61 cm)	24 in (61 cm)
G= Clearance to inside corner.	18 in (46 cm)	18 in (46 cm)
H = Clearance to each side of center line extended meter/regulator assembly above	3 feet (91 cm) within a height 15 feet (4.57 m) above the meter/regulator assembly.	3 ft (91 cm) within a height of 15 ft (4.6 m)
I = Clearance to service regulator vent outlet.	3 feet (91 cm)	3 ft (91 cm)
J = Clearance to nonmechanical air supply inlet to building or the combustion air inlet to any other appliance..	6 inches (15 cm) for appliances ≤ 10,000 Btuh (3 kW), 12 inches (30 cm) for appliances > 10,000 Btuh (3kW) and ≤ 100,000 Btuh (30kW), 36 inches (91 cm) for appliances > 100,000 Btuh (30kW).	4 feet (1.2 m) below or to side of opening; 1 foot (300 mm) above opening.
K = Clearance to mechanical air supply inlet.	6 feet (1.83 m)	3 feet (91 cm) above if within 10 feet (3 m) horizontally.
L = Clearance above paved side walk or paved driveway located on public property.	7 feet (2.13 m)+	7 feet (2.13 m)+
M = Clearance under veranda, porch, deck or balcony.	Not Allowed	Not Allowed

¹ In accordance with current CAN/CSA-B149.1 Installation Codes.

² In accordance with current ANSI Z223.1/ NFPA 54 National Fuel Gas Code.

+ A vent shall not terminate directly above a sidewalk or paved driveway that is located between two single family dwellings and serves both dwellings.

* "Clearance in accordance with local installation codes and the requirements of the gas supplier."

Typical Horizontal Direct Vent System

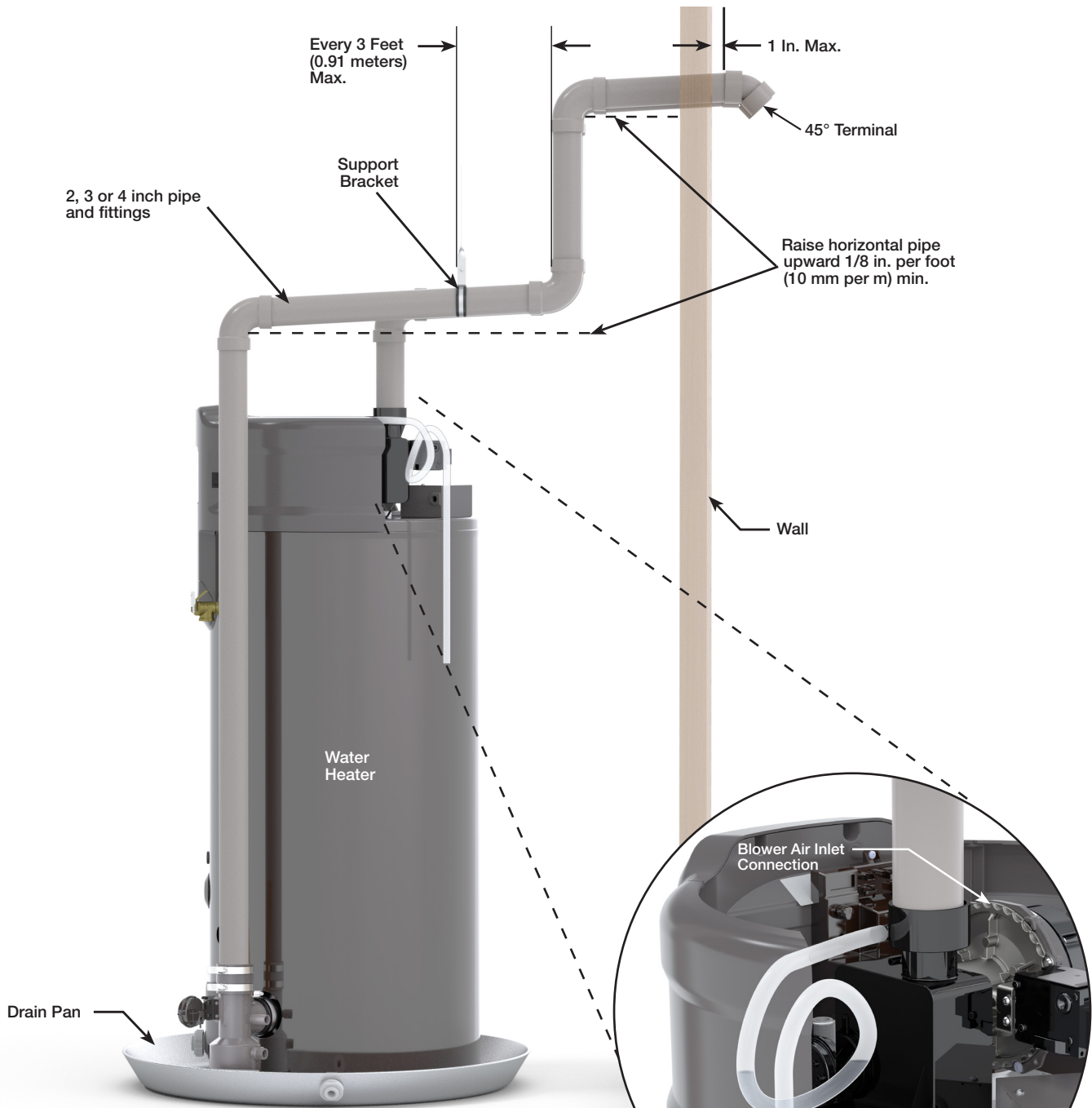

- Connect 1/2 in. I.D., flexible, PVC (or equivalent material), clear tubing to the drain port.
NOTICE: The tubing must be of sufficient length to reach a floor drain, outside the building or other required condensate disposal termination requirements (Refer to local codes).
- Loop the drain tube so that it has a circular trap and secure the top and bottom of the loop with wire ties or plastic zip ties as shown. **DO NOT** restrict any portion of the drain tube. The loop and all sections of the tube must not be restricted or collapsed.
- Fill the drain tube with water so that no combustion gases might vent into the room.
- Route the drain tube to a floor drain or outside the building or refer to local codes for any condensation requirements.

INSTALLATION

Typical Vertical Direct Vent System Installation

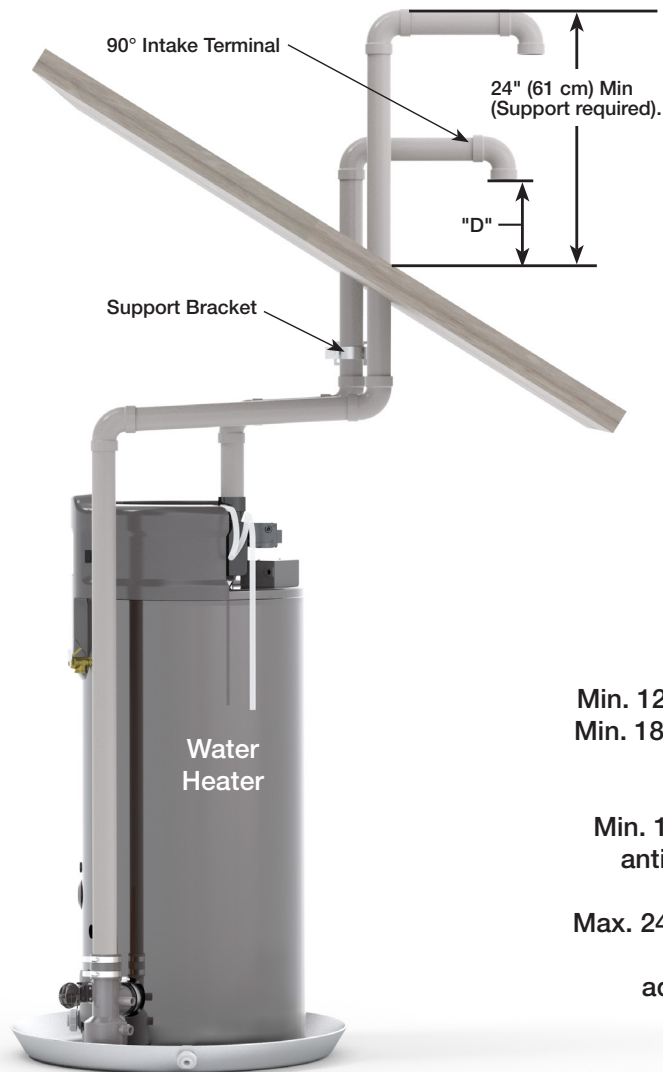

"D"

Min. 12 in. (30 cm) for US and
Min. 18 in. (46 cm) for Canada
above Roof

Min. 12 in. (30.5 cm) above
anticipated snow level

Max. 24 in. (61 cm) above roof
without
additional support

Terminals spacing for horizontal or vertical venting.

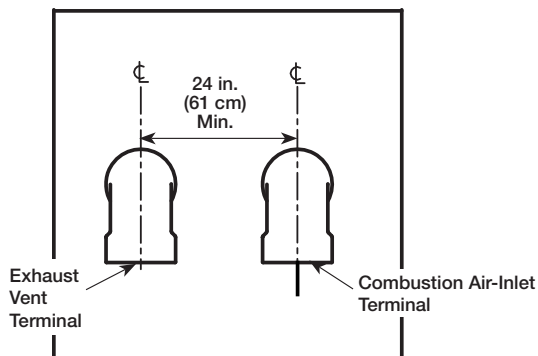

Terminals with 1/2 in. (1.3 cm) Mesh Protective Screen. Exercise discretion in using protective screens in cold climates to prevent formation of ice

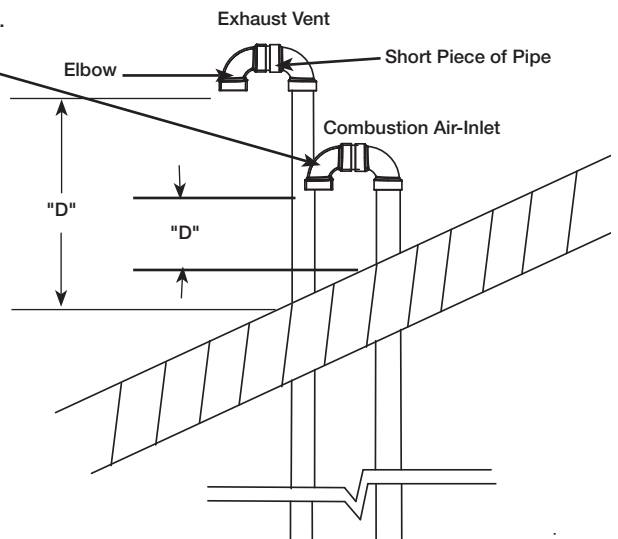

Direct Vent Vertical Vent Horizontal Intake



Direct Vent Horizontal Vent Vertical Intake



INSTALLATION

Typical Horizontal Power Vent System

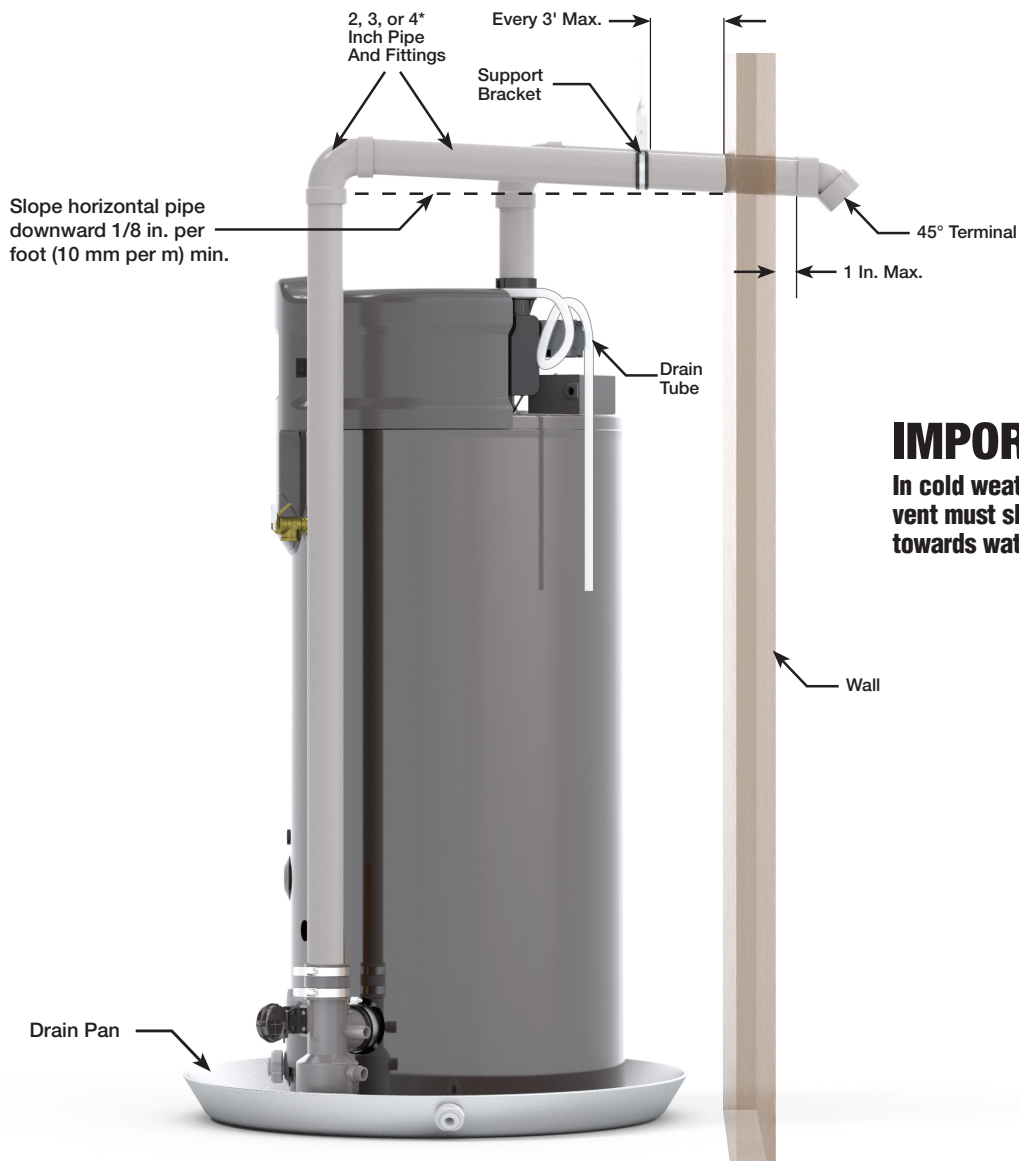

IMPORTANT:
In cold weather climates vent must slope back towards water heaters.

THROUGH THE WALL VENTING WITH LOW GROUND CLEARANCE:

When venting cannot exit through the wall at a height greater than or equal to 12" (30.5 cm) (and above expected snow level) from the ground, then the installation must be modified as shown below.

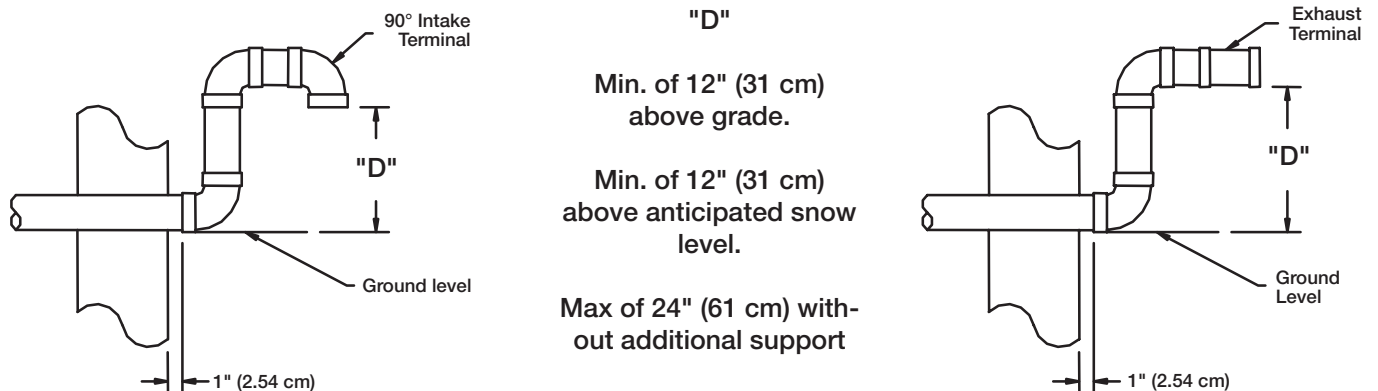

Typical Vertical Power Vent System Installation

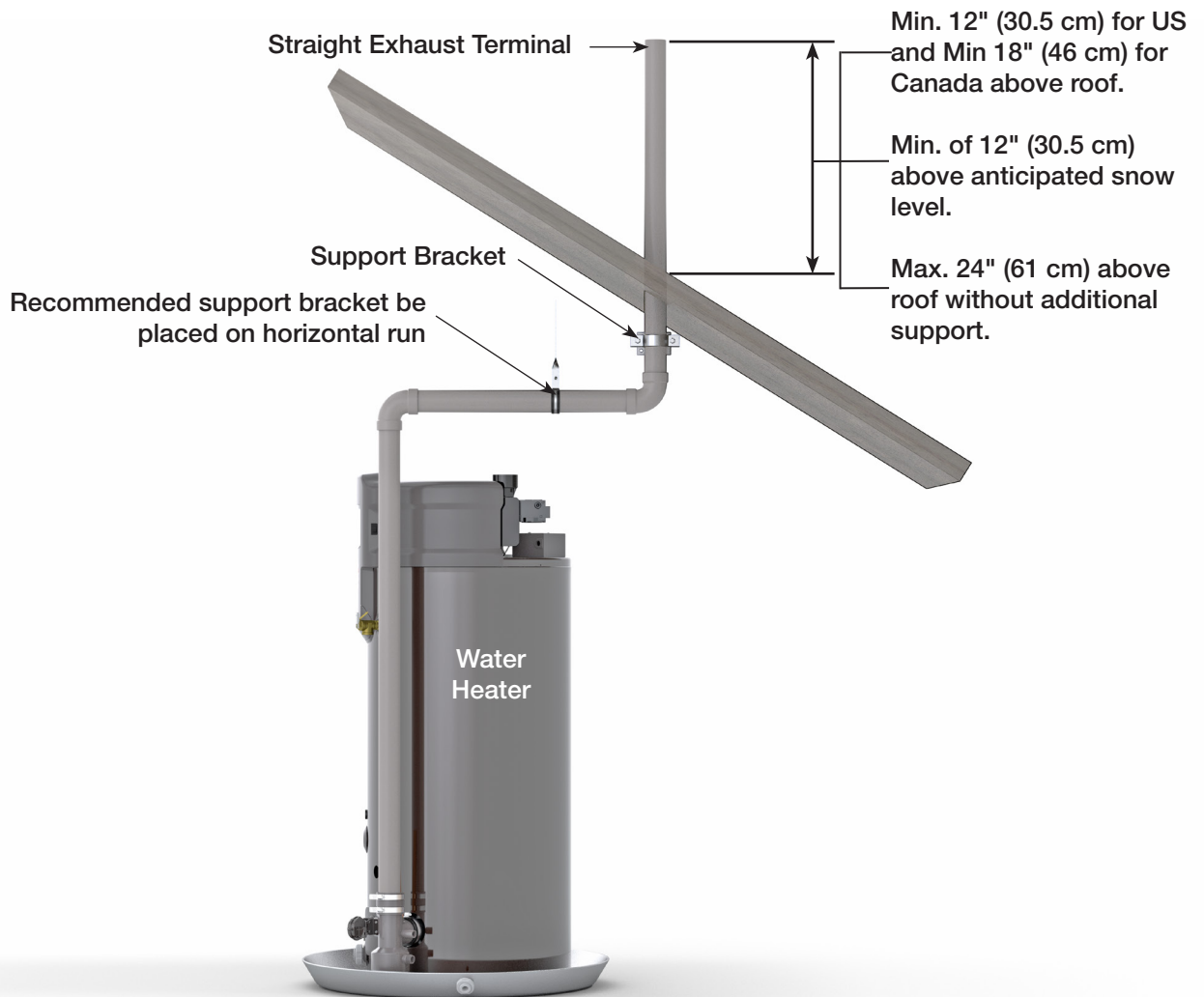

Alternate vertical venting with exhaust vent turned down - preferred for cold climates.

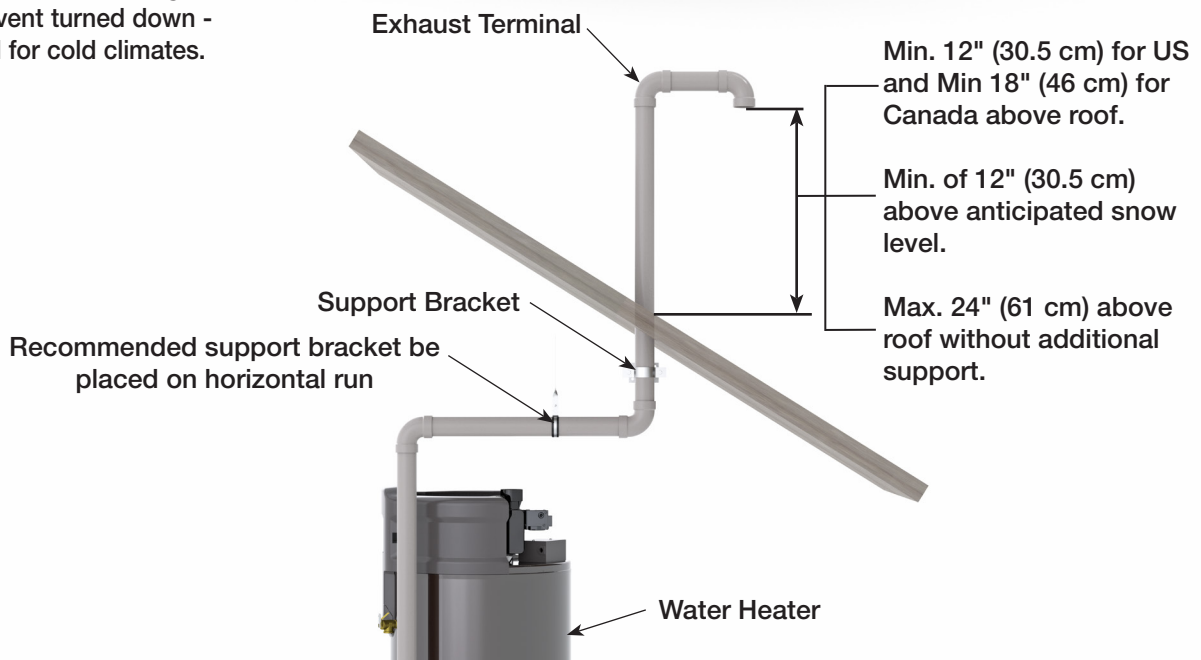

INSTALLATION

Concentric Vent Terminal Installation

PROCEDURE

Improper installation, adjustment, service, or maintenance can cause property damage, personal injury, or death. Consult a qualified installer, service agency, or gas supplier for information or assistance.

This kit must be used only for terminating this water heater. **DO NOT** use this termination kit for any other appliance. Using this kit on other appliances and/or water heaters can result in property damage, personal injury, or death.

NOTICE:

Concentric vent kit requires that the joints be cemented.

⚠ CAUTION:

DO NOT operate this water heater with the rain cap removed or recirculation of combustion products may occur. Water may also collect inside larger combustion-air pipe and flow to the burner assembly. Failure to follow this warning could result in product damage, improper operation, personal injury or death.

DO NOT use field-supplied couplings to extend pipes. Airflow restriction will occur and the water heater pressure switches may cause intermittent problems.

Nominal PVC Dimensions				
	"A"	"B"	"C"	"D"
2" Vent Kit	33.5"	17.65"	2.68"	3.5"
3" Vent Kit	39.5"	22.38"	3.83"	4.5" *
4" Vent Kit	53.75"	34.8"	4"	6"

*Hole size for nominal 4" PVC would be 5" (12.7 cm)

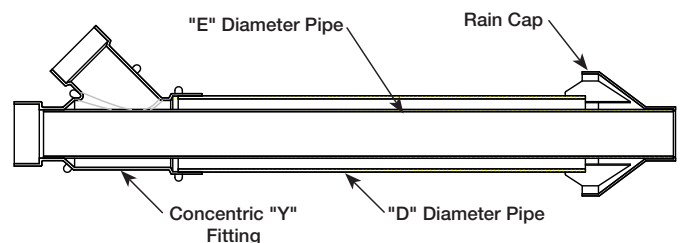
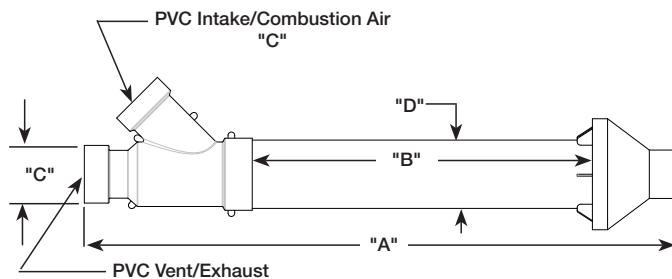

Installation:

1. Become familiar with concentric vent kit parts (see chart above).
2. Determine the best location for the termination kit.
3. Cut the recommended diameter hole for the nominal PVC pipe size called out in the charts above – Dim. "D".
4. Partially assemble the vent kit by performing the following:
 - a. Cement concentric Y fitting to larger diameter pipe (see chart above).
 - b. Cement rain cap to smaller diameter pipe (see charts above).

INSTALLATION

⚠ WARNING

These instructions are intended as an aid to qualified service personnel for proper installation, adjustment, and operation of this kit. Read these instructions thoroughly before attempting installation, adjustment, or operation. Failure to follow these instructions can result in improper installation, adjustment, service, or maintenance possibly resulting in fire, electrical shock, property damage, personal injury, or death.

⚠ WARNING:

This kit is to be used only for vent & combustion air-inlet termination for power direct vent gas water heaters. **DO NOT** use this kit to terminate any other type of appliance. Failure to follow this warning could result in fire, personal injury, or death.

LOCATION:

The Concentric Vent & Combustion Air-Inlet Termination Kit can be installed in a horizontal or vertical (roof) orientation. Before installation procedures begin, determine the best location for the termination kit.

IMPORTANT:

When installing the kit, consider the following when choosing a location:

- Kit is positioned where vent gases will not damage nearby structure.
- Kit is positioned so that wind will not cause combustion products, leaves, snow, or other debris to enter the combustion air-inlet.
- Kit is positioned where it will not get damaged by foreign objects (i.e.: balls, stones, etc.).
- Kit is positioned where vent gases will not be inhaled or cause a nuisance.

NOTE: Ensure that the heights of the vent and/or combustion air-inlet openings are at least 12" above the anticipated snow level.

HORIZONTAL INSTALLATION

STEP 1:

Cut the proper size opening (see "D" in chart) in the sidewall and install the field supplied weather-seal boot/flashing for PVC pipe.

STEP 2:

From inside, insert the combustion air-inlet pipe through the seal boot so that a maximum of 1" clearance occurs between the outside wall and the rain cap fins (see the following Figure). Ensure that no insulation or debris accumulate in the pipe.

HORIZONTAL AIR INLET PIPE INSTALLATION

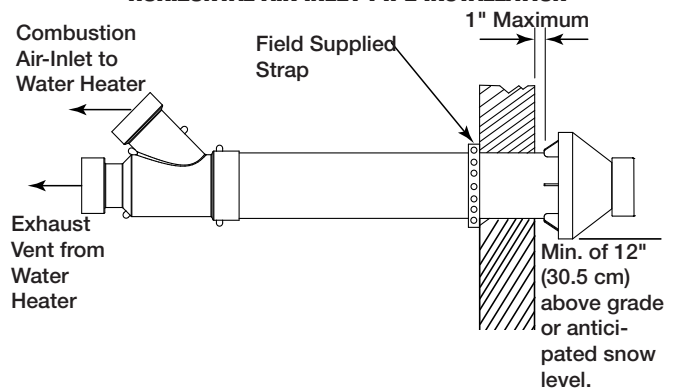

STEP 3:

Secure the combustion air-inlet pipe using a field supplied perforated strap of a suitable type material (see Figure above).

STEP 4:

Assemble the vent pipe assembly by cleaning and cementing the rain cap to the smaller diameter vent pipe.

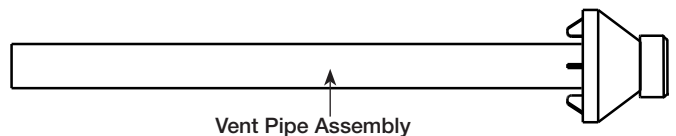

Note: If field disassembly is desired for cleaning, a stainless steel screw may be used to secure the rain cap to the PVC vent pipe.

⚠ WARNING:

When using the alternate screw method, pre-drill a clearance hole in the rain cap slightly larger than the screw and a pilot hole in the vent pipe to prevent cracking of the PVC pipe. Cracking of the PVC components will cause a failure of the system, allowing combustion products to be recirculated. Failure to follow this warning could result in personal injury or death.

⚠ WARNING:

DO NOT operate the water heater with the rain cap and elbow removed or recirculation of combustion products may occur. The vent and combustion air-inlet systems may also take in water, causing damage to the water heater. Failure to follow this warning could result in damage to the unit, improper operation, personal injury, or death.

STEP 5:

From the outside, slide the vent pipe assembly through the combustion air-inlet pipe and cement the rain cap to the combustion air-inlet pipe. From the inside, cement the "Y" fitting to the combustion air-inlet pipe (refer to Figures in this page).

INSTALLATION

STEP 6:

Complete the installation of the remainder of the vent and combustion air-inlet systems as required in this manual.

VERTICAL INSTALLATION

STEP 1:

Cut a proper size opening (see "D" in chart) in the roof, and install field-supplied weather-seal boot/flashing for the larger PVC pipe.

STEP 2:

From inside, insert the larger diameter combustion air-inlet pipe up through the seal boot, ensuring that no insulation or debris accumulate in the pipe. Ensure termination height is above the 12" minimum clearance to combustion air inlet.

STEP 3:

Secure the combustion air-inlet pipe using a field supplied perforated strap or a suitable type material. (see the Vertical Air Inlet Pipe Installation Figure in this page).

STEP 4:

Assemble the vent pipe assembly by cleaning and cementing the rain cap to the smaller diameter exhaust pipe. Assemble the 90° elbow by cleaning and cementing it to the rain cap. Assemble the field supplied PVC connector and 90° elbow by cleaning and cementing them together as shown in Vertical Air Inlet Pipe Installation Figure on this page. The alternate screw method is not necessary for the field supplied PVC parts.

NOTE: If field disassembly is desired for cleaning, a stainless steel screw may be used to secure the rain cap to the smaller diameter exhaust pipe.

⚠ WARNING:

When using the alternate screw method, pre-drill a clearance hole in the rain cap slightly larger than the screw and a pilot hole in the vent pipe to prevent cracking of the PVC pipe. In a separate location, pre-drill a slightly larger clearance hole in the 90° elbow and a pilot hole in the rain cap for the screw being used at that site. Cracking of the PVC components will cause a failure of the system, allowing combustion products to be recirculated. Failure to follow this warning could result in personal injury or death.

⚠ WARNING:

DO NOT operate the water heater with the rain cap removed or recirculation of combustion products may occur. The vent air pipes may also take in water, causing damage to the water heater. Failure to follow this warning could result in damage to the unit, improper operation, personal injury, or death.

STEP 5:

From the roof top, slide the vent pipe assembly down through the intake pipe and cement the rain cap to the intake pipe. From the inside, cement the "y" fitting to the intake pipe (See Figure below).

VERTICAL AIR INLET PIPE INSTALLATION

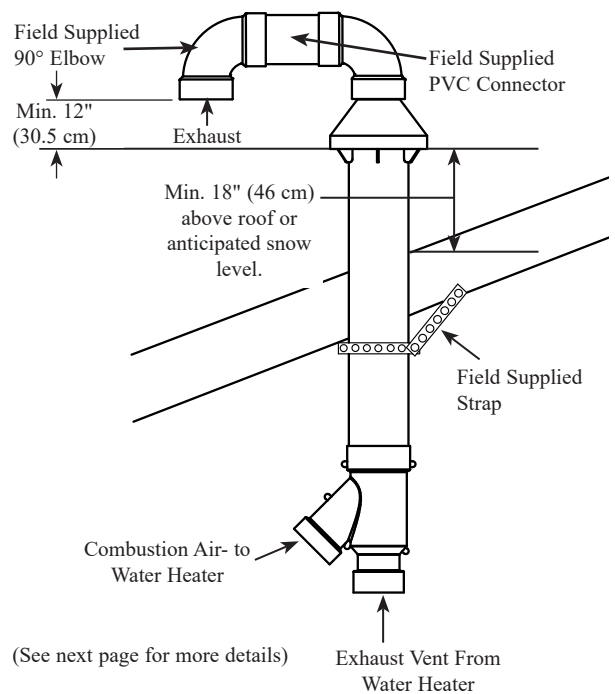

Alternative Vertical Vent Termination

Alternative vertical vent termination kits are commercially available. Please refer to the instruction sheet packaged with the kit for complete installation instructions.

⚠ WARNING:

Under no circumstances should the exhaust pipe and the air intake pipe be connected together.

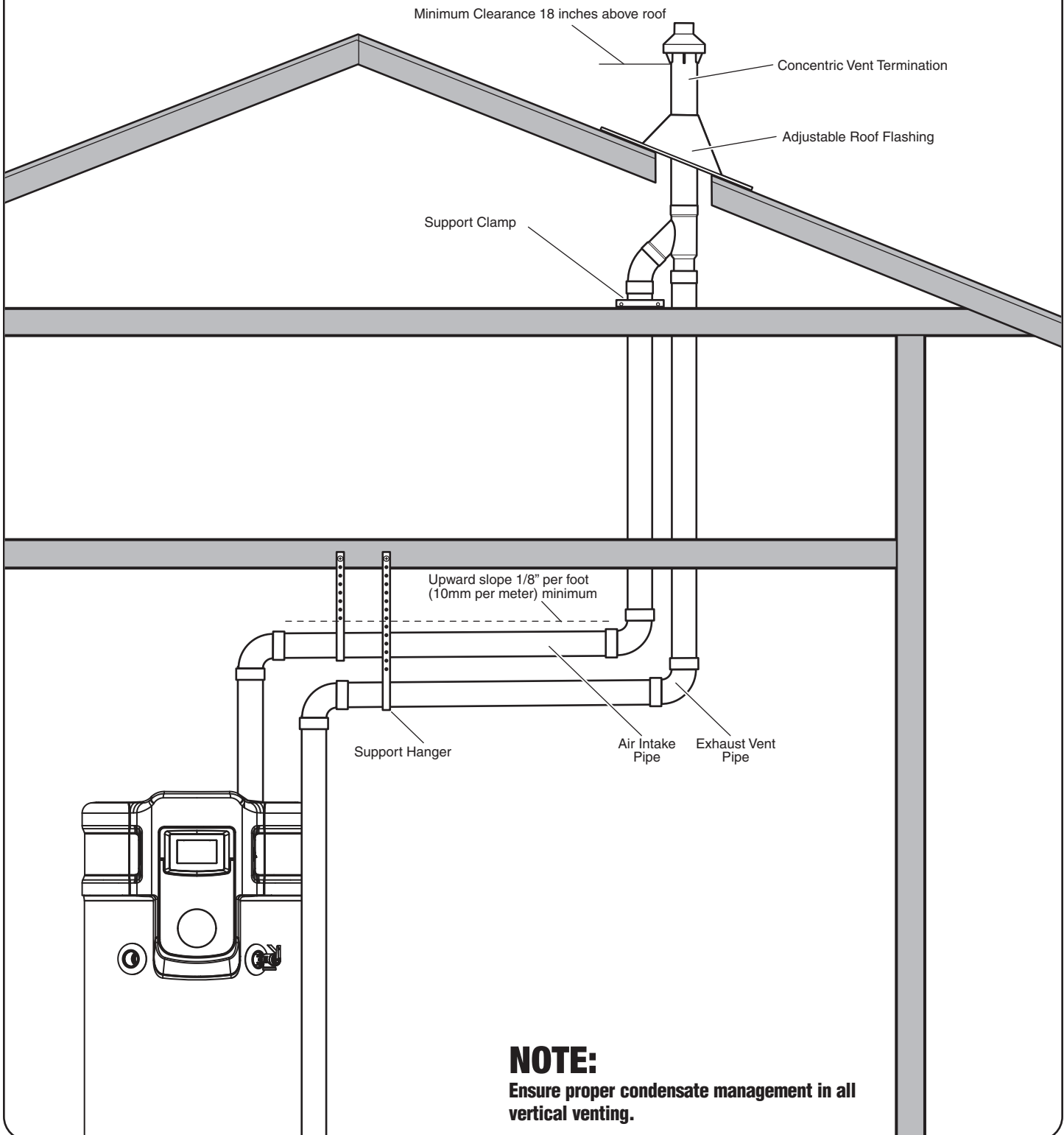

NOTE:

Ensure proper condensate management in all vertical venting.

INSTALLATION

Alternative Horizontal Vent Installations

Alternative flat horizontal vent termination kits are commercially available for 2" and 3" pipes. Please refer to the instruction sheet packaged with the kit for complete installation instructions.

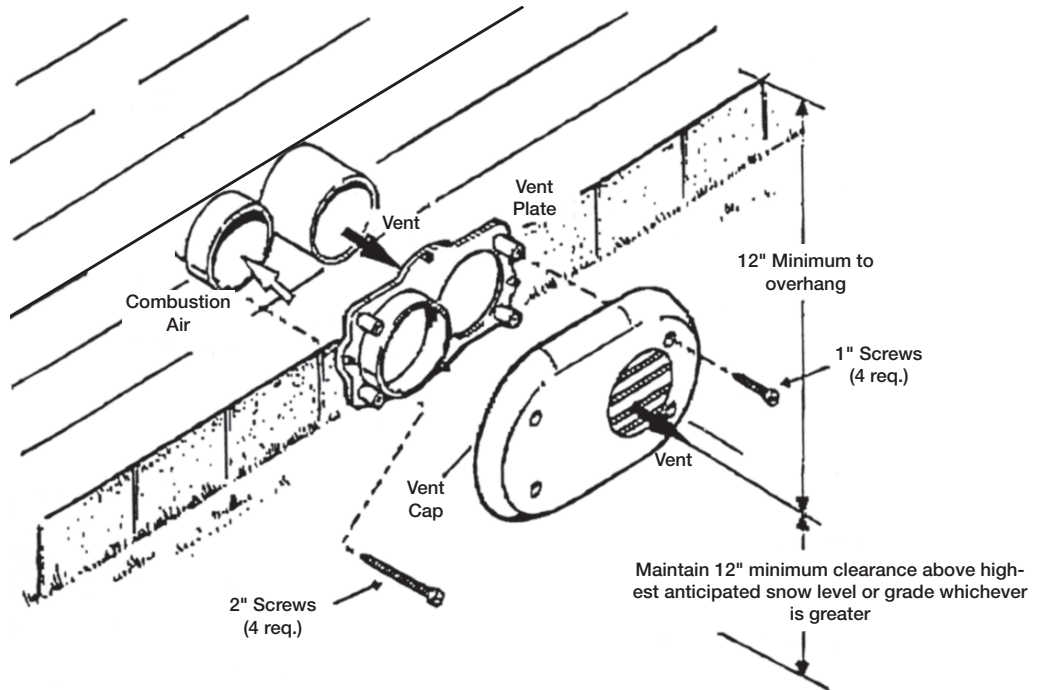
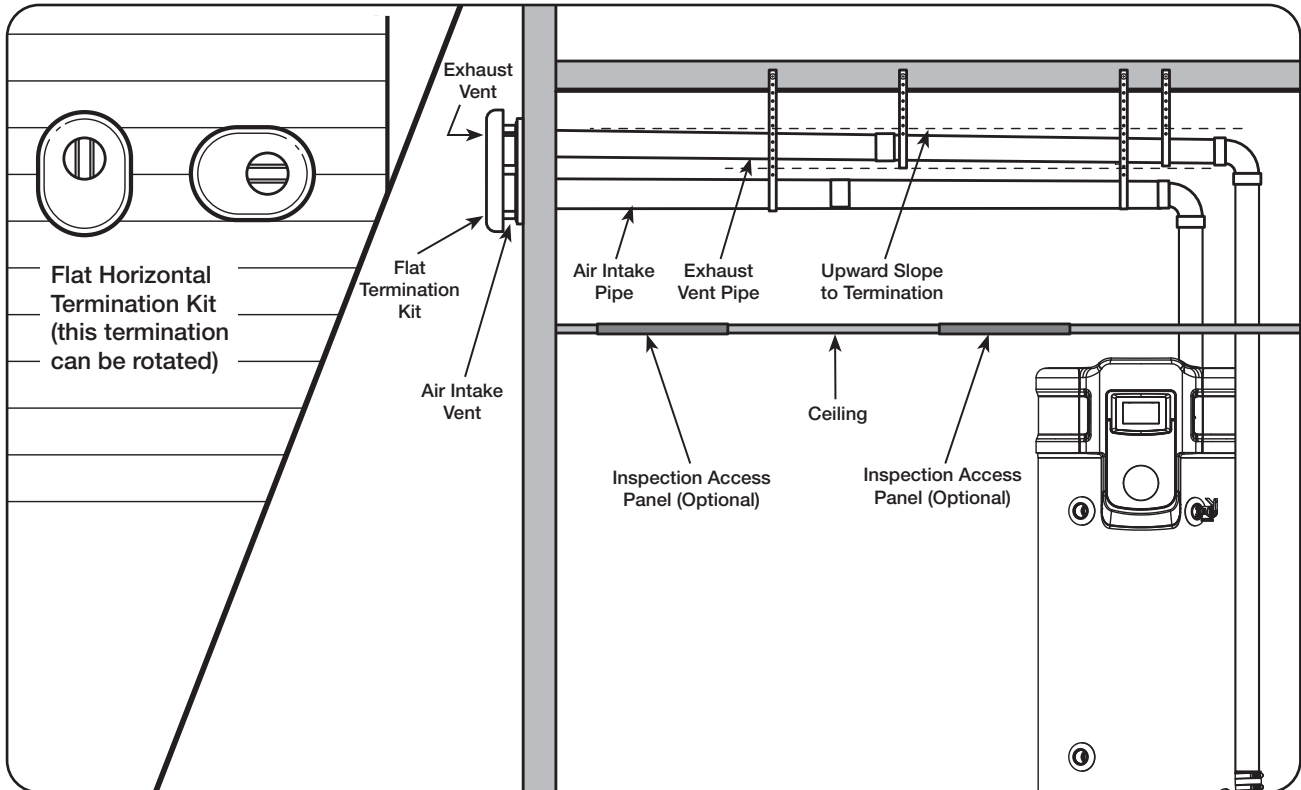

INSTALLATION CHECK LIST

To be able to use a PVC termination, a short piece of PP pipe will need to be cut, as shown below, to transition from the bell end of the pipe to the PP to PVC adapter.

A. Water Heater Location

- Close to vent locations
- Located indoors and protected from freezing temperatures
- Proper clearance from combustible surfaces
- Air supply free of corrosive elements and flammable vapors.
- Sufficient room to service the heater
- Water heater protected from water damage

B. Water Supply

- Water heater completely filled
- Air purged from water heater and piping
- Water connections tight and free of leak

C. Gas Supply

- Gas line equipped with shut-off valve, union, and sediment trap
- Minimum pipe size 1/2"; No flex pipe
- Soap and water solution used to check all connections for gas leaks
- Approved pipe joint compound used

D. Relief Valve

- Discharge line run to open drain
- Discharge line protected from freezing

E. Venting

- Water heater vented separately from all other appliances
- All vent and air intake pipe connections are secure
- Vent and air intake pipes properly supported at regular intervals
- Precaution on taken to avoid moisture damage around vent termination
- Drain tube attached to sound damper if needed. If not, ensure cap is in place

F. Condensate

- Condensate trap installed and primed.
- Condensate neutralizer installed

G. Wiring

- Correct power supply (120VAC)
- Electrical connections are tight
- Water heater is properly grounded with proper polarity.

Length Pipe Table For U.S. Installations

Maximum Capacity of Pipe in Cubic Feet of Gas per Hour for Gas Pressures of 0.5 psig or Less and a Pressure Drop of 0.3 Inch Water Column
Based on a 0.60 Specific Gravity Natural Gas; If 1.5 Specific Gravity L.P. Gas is used, multiply capacity by 0.63

Nominal Iron Pipe Size Inches	Internal Diameter Inches	Length of Pipe, Feet													
		10	20	30	40	50	60	70	80	90	100	125	150	175	200
1/2	0.622	132	90	73	62	55	50	46	43	40	38	34	31	28	26
3/4	.824	278	190	152	130	115	105	96	90	84	79	72	64	59	55
1	1.049	520	350	285	245	215	195	180	170	160	150	130	120	110	100
1 1/4	1.380	1,050	730	590	500	440	400	370	350	320	305	275	250	225	210
1 1/2	1.610	1,600	1,100	890	760	670	610	560	530	490	460	410	380	350	320
2	2.067	3,050	2,100	1,650	1,450	1,270	1,150	1,050	990	930	870	780	710	650	610
2 1/2	2.469	4,800	3,300	2,700	2,300	2,000	1,850	1,700	1,600	1,500	1,400	1,250	1,130	1,050	980
3	3.068	8,500	5,900	4,700	4,100	3,600	3,250	3,000	2,800	2,600	2,500	2,200	2,000	1,850	1,700
4	4.026	17,500	12,000	9,700	8,300	7,400	6,800	6,200	5,800	5,400	5,100	4,500	4,100	3,800	3,500

For maximum pipe capacity for installations in Canada, refer to CAN/CSA B149.1. For natural gas, refer to Tables A.1 through A.17. For propane (LP) gas, refer to Tables B.1 through B.12.

OPERATION

Before operating this water heater, be sure to read and follow the instructions on the label pictured below and all other labels and warnings on the water heater and printed in this manual. Failure to do so can result in unsafe operation of the water heater resulting in property damage, bodily injury, or death. Should you have any problems reading or understanding the instructions in this manual, STOP, and get help from a qualified person.

FOR YOUR SAFETY READ BEFORE OPERATING

WARNING: If you do not follow these instructions exactly, a fire or explosion may result causing property damage, personal injury or loss of life.

- A. This appliance does not have a pilot. It is equipped with an ignition device which automatically lights the burner. Do not try to light the burner by hand.
- B. BEFORE OPERATING smell all around the appliance area for gas. Be sure to smell next to the floor because some gas is heavier than air and will settle on the floor.
- WHAT TO DO IF YOU SMELL GAS
- Do not try to light any appliance.
 - Do not touch any electrical switch; Do not use any phone in your building.
 - Immediately call your gas supplier from a neighbor's phone, and follow the gas supplier's instructions.
- If you cannot reach your gas supplier, call the fire department.
- C. Use only your hand to turn the gas control knob. Never use tools. If the knob will not turn by hand, don't try to repair it. Call a qualified service technician. Force or attempt to repair may result in a fire or explosion.
- D. Do not use this appliance if any part has been under water. Immediately call a qualified service technician to inspect the appliance and to replace any part of the control system or any gas control which has been under water.

OPERATING INSTRUCTIONS

1. STOP! READ THE SAFETY INFORMATION ABOVE ON THIS LABEL.
2. SET THE "ON/OFF" SWITCH NEXT TO THE CONTROL DISPLAY TO THE "OFF" POSITION.
3. THIS APPLIANCE IS EQUIPPED WITH AN IGNITION DEVICE WHICH AUTOMATICALLY LIGHTS THE BURNER.
4. IF YOU THEN SMELL GAS, STOP! FOLLOW "B" IN THE SAFETY INFORMATION ABOVE ON THIS LABEL. IF YOU DON'T SMELL GAS, GO TO THE NEXT STEP.
5. TURN ON ALL ELECTRICAL POWER TO THE APPLIANCE, WITH THE SWITCH LOCATED TO THE RIGHT OF THE CONTROL DISPLAY.
6. IF THE APPLIANCE WILL NOT OPERATE, FOLLOW THE INSTRUCTIONS "TO TURN OFF GAS TO APPLIANCE".
7. WATER TEMPERATURE ADJUSTMENT IS APPROXIMATELY 120°F. (49°C.) SET THE TO THE DESIRED TEMPERATURE SETTING THERMOSTAT

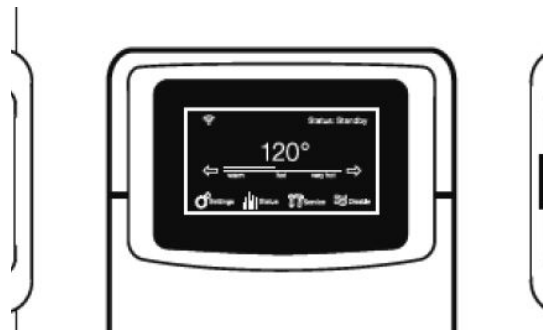

CAUTION: HOTTER WATER INCREASES THE RISK OF SCALD INJURY. CONSULT THE INSTRUCTION MANUAL BEFORE CHANGING THE TEMPERATURE.

WARNING: TURN OFF ALL ELECTRIC POWER BEFORE SERVICING.

TO TURN OFF GAS TO APPLIANCE

1. TURN OFF ALL ELECTRIC POWER TO THE APPLIANCE IF SERVICE IS TO BE PERFORMED.
2. TURN THE "MANUAL GAS VALVE KNOB" TO THE "OFF" POSITION.

SAFETY PRECAUTIONS

- A. Do not turn off manual gas shut-off valve if water heater has been subjected to over heating, fire, flood, physical damage or if gas supply fails to shut off.
- B. **DO NOT** turn on water heater unless it is filled with water.
- C. **DO NOT** turn on water heater if cold water supply shut-off valve is closed.
- D. **DO NOT** store or use gasoline or other flammable vapors and liquids, such as adhesives or paint thinner, in vicinity of this or any other appliance. If such flammables must be used, open doors and windows for ventilation, and all gas burning appliances in vicinity should be shut off, including their pilot lights, to avoid vapors igniting.

NOTICE: Flammable vapors may be drawn by air currents from surrounding areas to the water heater.

- E. **DO NOT** allow combustible materials such as newspaper, rags or mops to accumulate near water heater.

- F. If there is any difficulty in understanding or following the OPERATION or MAINTENANCE instructions, it is recommended that a qualified person or serviceman perform the work.

⚠ WARNING:

Hydrogen gas can be produced in a hot water system served by this water heater that has not been used for a long period of time (generally two weeks or more). **HYDROGEN GAS IS EXTREMELY FLAMMABLE!!** To dissipate such gas and to reduce risk of injury, it is recommended that the hot water faucet be opened for several minutes at the kitchen sink before using any electrical appliance connected to the hot water system. If hydrogen is present, there will probably be an unusual sound such as air escaping through the pipe as the water begins to flow. **DO NOT** smoke or use an open flame near the faucet at the time it is open.

1. TEMPERATURE SETTINGS — The temperature is adjusted to the lowest setting when shipped from the factory. To meet residential water use needs, the temperature on this water heater is adjustable up to 160°F (71° C). However, water temperatures over 125°F (52°C) can cause severe burns instantly or death from scalds. This is the preferred starting point for setting the control for supplying general purpose hot water.

Safety and energy conservation are factors to be considered when setting the water temperature. The most energy efficient operation will result when the temperature setting is the lowest that satisfies the needs consistent with the application.

⚠ DANGER:

Hotter water increases the potential for hot water SCALDS.

When this water heater is supplying general purpose hot water requirements for individuals, a thermostatically controlled mixing valve for reducing point of use water temperature is recommended. Contact a licensed plumber or the local plumbing authority for further information.

Outlet water temperature will vary during normal operating cycles. Reliable temperature readings should be taken shortly after main burner cycles off during a period of little or no use.

2. EMERGENCY SHUTDOWN —

⚠ WARNING:

Should overheating occur or the gas supply fail to shut off, turn off the manual gas control valve to the appliance.

DO NOT use this appliance if any part has been under water. Immediately call a qualified service technician to inspect the appliance and to replace any part of the control system or any gas control which has been under water.

If the water heater has been subjected to fire or physical damage, turn off gas at the manual gas control (shut-off) valve. **DO NOT** operate the water heater again until it has been checked out by a qualified service technician.

USER INTERFACE

NAVIGATING THE HOME SCREEN:

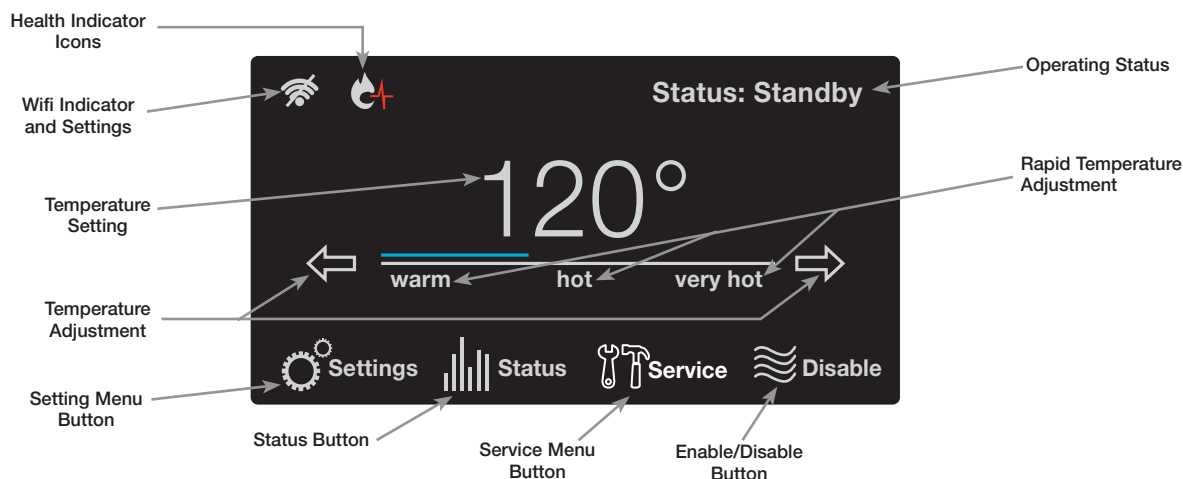

STARTUP

Once power is applied to the water heater and the On button is pressed, the Startup Wizard on the LCD will go over the below features:

1. Setting of Time and Date
2. Setting Hours of Operation for the business
3. Wifi Setup

Follow the on-screen instructions to complete setup. Some of these items can be skipped if a later setup is desired.

ENABLING (TURNING ON) THE UNIT

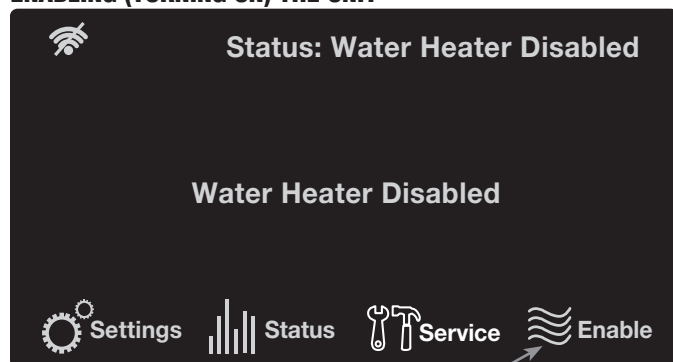

Press the enable button to turn the water heater on

TEMPERATURE ADJUSTMENT

Tank temperature will be maintained according to the setting on the home screen. If the water temperature setting needs adjustment, use the arrows on the display to select desired temperature.

The display also has a rapid temperature adjustment feature that corresponds to the below temperature settings.

- Warm: 110°F (43°C)
- Hot: 120°F (49°C)
- Very hot: 160°F (71°C)

Touching the text 'warm', 'hot', or 'very hot' will adjust the temperature to the above temperature setting.

SETTING MENU

The settings function on the water heater display allows access to the basic settings, configurations, schedules, and the time/date.

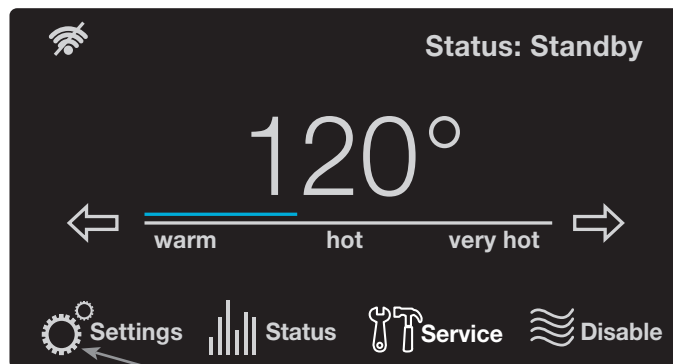

Pressing the settings button will allow access to water heater settings

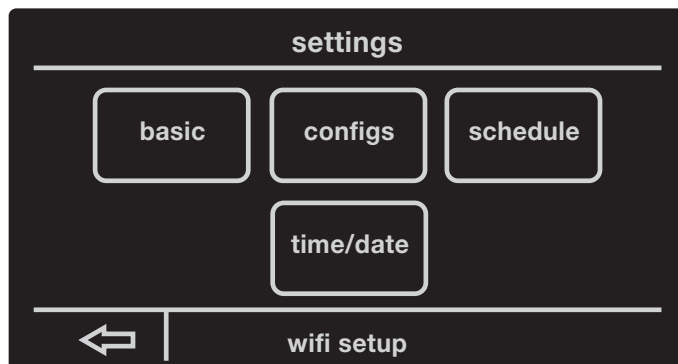

⚠ DANGER:

Hotter water increases the potential for hot water SCALDS.

USER INTERFACE

BASIC SETTINGS: The basic settings in your water heater can allow you to change the temperature unit, screen adjustment lock/unlock, enabling/disabling the alarm beep, and your EcoNet network instance. Simply select the setting by tapping it, and press the Up/Down arrows to make adjustments. WiFi setup can be accessed from this screen as well.

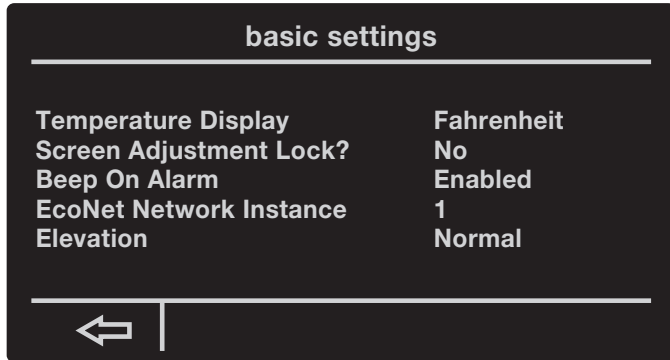

CONFIGURATION SETTINGS: The configuration settings on your water heater allows you to control the heating mode, setting the recirculation pump, auxiliary input/output, enabling/disabling modulation, and how your hot water heater reacts to a detected leak.

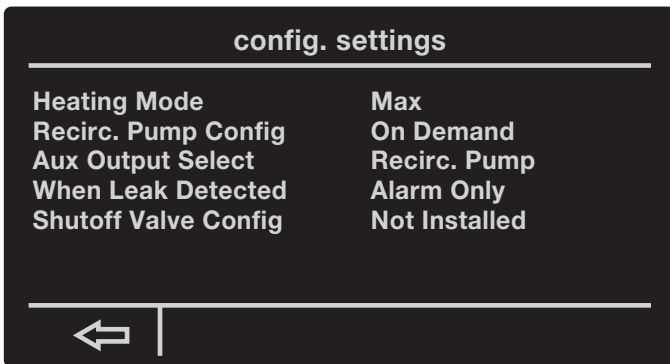

The setting can be highlighted by tapping and then adjusted with the up/down arrows.

The heating mode can be set as Normal or Max. In Max mode, the heater can deliver more hot water by heating the water sooner following a draw. Max mode uses more energy than Normal mode. If selected, Max mode will timeout after 20 minutes, and the heater will return to Normal mode.

Recirculation Pump Configuration can be set to the following:

Off - use this setting when the recirculation pump is not in use, or not installed.

On - use this setting to manually turn on the pump. Useful for testing the setup. Not recommended for general use.

Schedule - The recirculation pump will run on a 15 min On/15 min Off cycle whenever the heater is set to the "Home" mode (see SCHEDULE SETTINGS). When the heater is in an Away mode, the recirculation pump will not run.

On Demand - The recirculation pump can be triggered to run from the mobile app. When triggered from the app, the pump will run for 15 min.

This water heater has a modulation algorithm that can be disabled by tapping 'No' in front of Modulation Disabled and making adjustments by tapping the up/down buttons.

SCHEDULE SETTINGS: The schedule settings allows you to control when your hot water heater will be enabled/disabled. Your heater allows you to select a day you want and set the times when the heater will be in use. You can also copy/paste the day you select and apply it to other days as well.

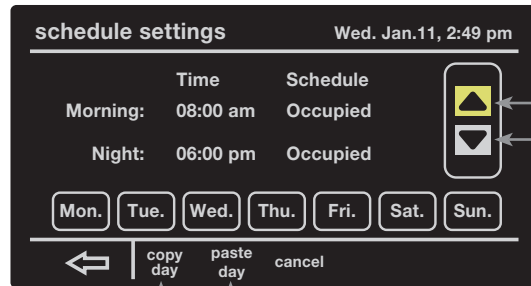

By selecting a day and then accessing the copy function, you can paste that day's settings onto other

The up/down arrows enable you to adjust the time of the period run times.

TIME/DATE SETTINGS: By selecting time/date you can change the water heaters current set time. You can also select the daylight savings time function to automatically adjust the time for daylight savings.

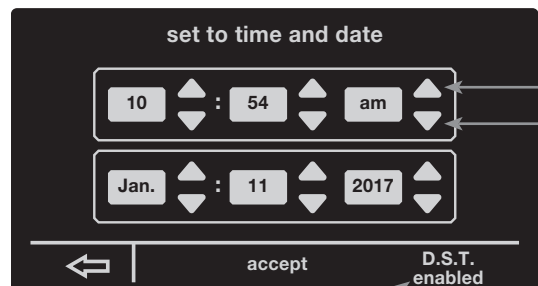

The D.S.T function allows you to adjust the time for daylight savings time.

The up/down arrows allow you to control the time, month, day, and year.

STATUS MENU

The Status screen provides information on the current operating status, diagnostics and sensors. This screen also provides information on the WiFi status.

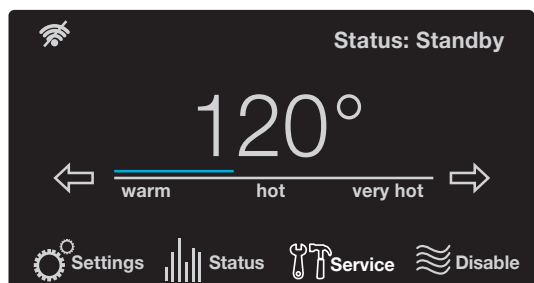

By pressing the Status button, you will be taken to a prompt showing the state of your water heater's many features.

USER INTERFACE

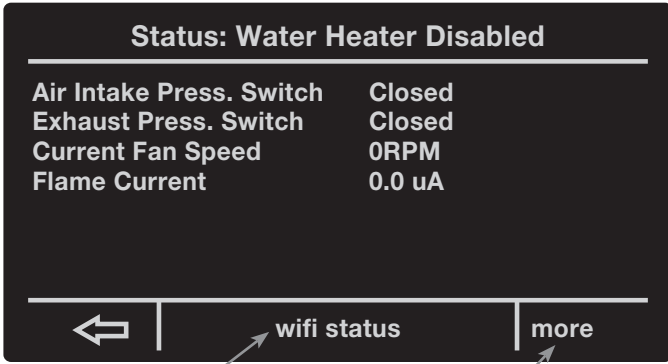

By selecting Wi-Fi status, you can access the status of your water heater's Wi-Fi and even set it up.

By selecting more, you can access the temperatures of your water heater, ECO switch state, and auxiliary switch state.

WI-FI STATUS: After selecting the Wi-Fi status function, you will be brought to a prompt showing you the current state of your water heater's Wi-Fi and the ability to set-up your water heater's Wi-Fi.

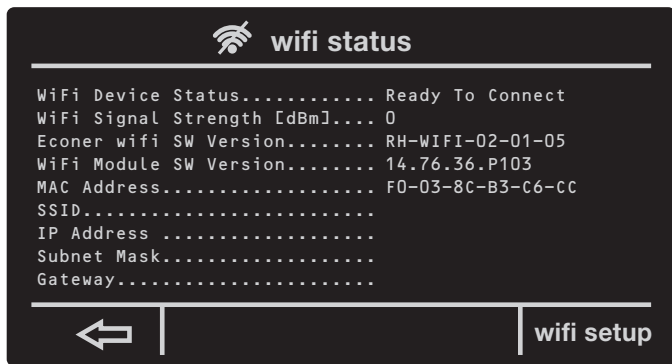

Selecting the Wi-Fi setup function will bring you to a prompt allowing you to connect your water heater to your home Wi-Fi.

MORE FUNCTION: Selecting the more function your heater will bring you to a prompt showing you the current temperatures of the lower/upper tank, Flue temperature, ECO switch state, and Auxiliary relay state.

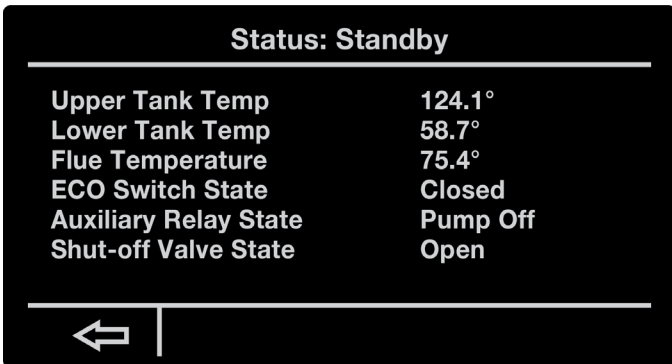

SERVICE MENU

The service screen provides information on the product description, alarms, system health, and service alerts. Alarm details can be found in the "Before You Call Service" section of the manual.

In case there is an active alarm, the "Service" button will blink on the home screen. Pressing the "Service" button will show a new screen containing the active alarms and alarm history.

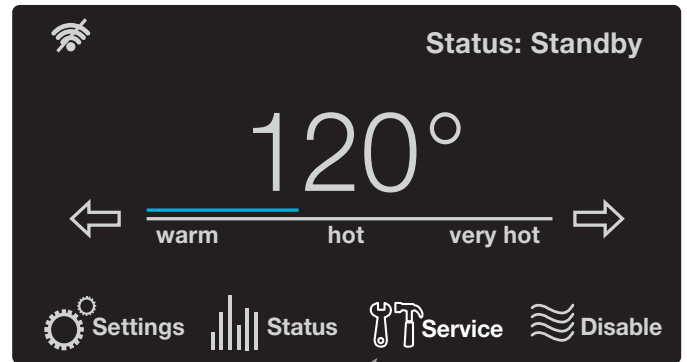

By selecting the service function, you will be taken to a prompt giving you access to the heater's alarms, health, and alerts.

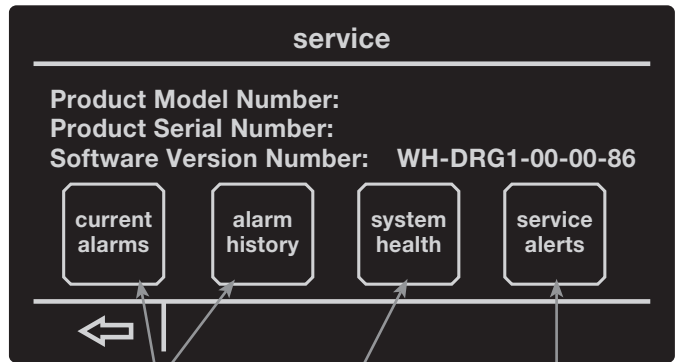

Current Alarms and Alarm History allows you to access any current alarms that have been tripped and view a list of previous alarms.

System Health will show you the status of the tank's combustion health and overall tank health.

Service Alerts will allow you to set how often you want to be alerted to check venting, clean the drain trap, replace the neutralizer, and to drain and inspect the tank.

USER INTERFACE

ALARMS: The current alarms function allows you to see any problems that have been detected by your water heater. Also, by selecting on the current alarm you can press “more info” to read more on the current problem of your water heater. Alarm history allows you to see any of the previous alarms that have gone off in the past and give you the ability to clear those previous alarms.

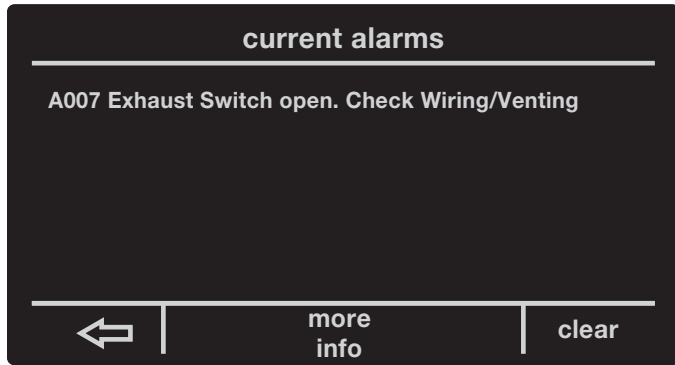

By selecting “more info” you can be given a more in-depth explanation of the current alarm.

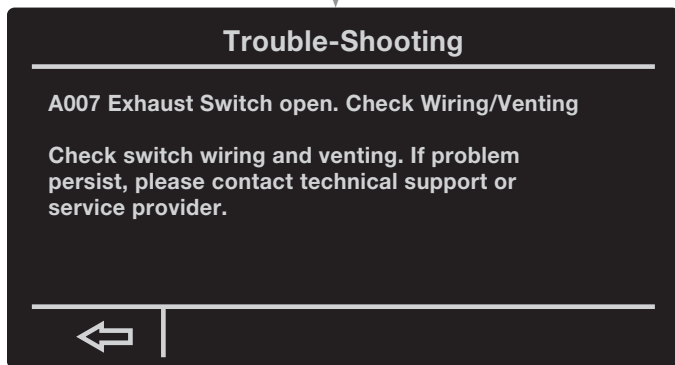

ALARM HISTORY: The alarm history function allows you to see the previous alarms that have been detected by your water heater in the past.



SYSTEM HEALTH: The system health function allows you to see the current health of your hot water heater’s combustion health. The combustion health has three levels of health:

This symbol will appear on your home screen if your combustion health is critical. Pressing this icon will take the user to the Health Status Screen

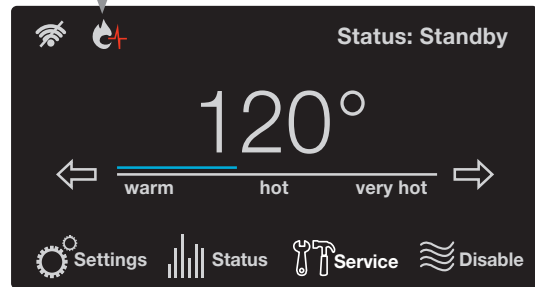

COMBUSTION HEALTH:

1. Normal operation - no action needed
2. Reliability Decreasing - begin planning for service and/or replacement.
3. Needs Servicing - contact your service provider

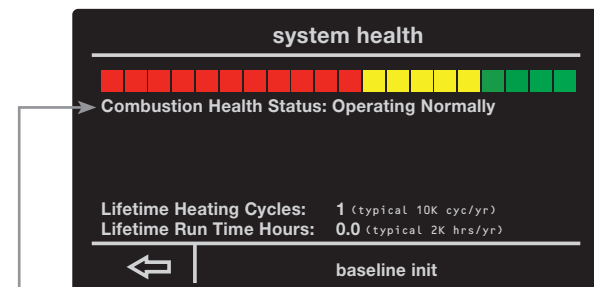

The health of your system’s combustion system and overall health can be seen here. This screen be accessed by tapping the health indicator icons on the home screen.

SERVICE ALERTS: By selecting the Service alerts function you will be able to adjust how often you want to be alerted to drain and inspect the tank, clean the drain trap, check the venting, and to replace the neutralizer.

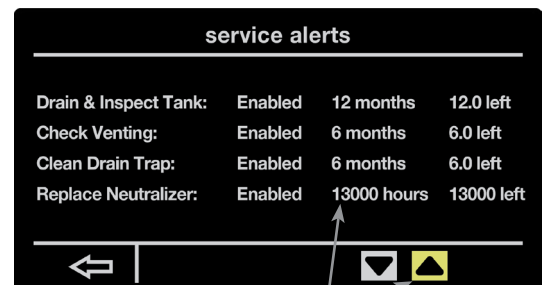

By selecting an option and then using the up and down arrow, you can set how often you’d like to be alerted to system maintenance.

MAINTENANCE

Properly maintained, this water heater will provide years of dependable, trouble free service. It is strongly suggested that a regular routine maintenance program be established and followed by the owner. It is further recommended that a periodic inspection of the relief valve and venting system should be made by service technicians qualified in gas appliance repair.

1. ROUTINE PREVENTIVE MAINTENANCE

- A. PRESSURE SWITCH** — Inspect the inlet to the pressure switch and the tubing for debris or blockage. Clean out the tubing periodically to prevent buildup of debris.
- B. CONDENSATE TRAP** — Check for blockages.
- C. ELECTRICAL CONNECTIONS** — Periodic inspection of all electrical connections and wiring conditions.

CAUTION:

⚠ Label all wires prior to disconnection when servicing controls. Wiring errors can cause improper and dangerous operation.

CAUTION:

⚠ VERIFY PROPER OPERATION AFTER SERVICING !

Make certain all power to the water heater is turned "OFF" before performing any maintenance or inspection work on this water heater.

Before manually operating the relief valve, make certain no one will be exposed to the danger of coming in contact with the hot water released by this valve. The water may be hot enough to create a SCALD hazard. The water released should be directed to a suitable drain to prevent injury or damage.

NOTICE: If the temperature and pressure relief valve on the water heater discharges periodically, this may be due to thermal expansion in a "closed" water system. Contact the water supplier or local plumbing inspector on how to correct this. **DO NOT** plug the relief valve outlet.

- E. TANK**— Good maintenance requires that the tank be cleaned of deposits. Unless the water supply is soft (0 to 5 grains hardness), scale or lime deposits will accumulate in the tank. Hard water scale is deposited at an increasingly high rate in proportion to increased water temperature. Accumulation of these deposits may reduce efficiency, and shorten the life of the water heater.

Replace with - Drain a few quarts of water from the water heater's tank every month to clean the tank of these deposits.

F. SEASONAL OPERATION - If the water heater is to remain idle for an extended period (60 days or more) the heater should be turned off. The water heater and piping should be drained if they might be subjected to freezing temperatures. It is recommended that the water heater's operation is thoroughly checked (by a qualified service technician) before it is placed back in service. **NOTICE:** Refer to the Hydrogen Gas caution notation on "Safety Precautions" section of this manual.

G. VENTING SYSTEM — Inspect the venting system at least yearly to make certain the passageways are free and unobstructed, and that the vent connector from the water heater's blower assembly is properly positioned and securely attached. Remove any obstructions in the vent connector or vent terminal.

BEFORE YOU CALL FOR SERVICE...



Troubleshooting Tips

Save time and money! Review the charts on the following pages first and you may not need to call for service.

If one of the health indicators is blinking on the home screen or the service icon is blinking there is an issue with the operation of your water heater. Pressing the service icon will allow you to look at Current Alarms (and Alerts), Alarm History, and Unit Health screens for issues that need attention. Pressing the blinking health indicator will show the health screen.

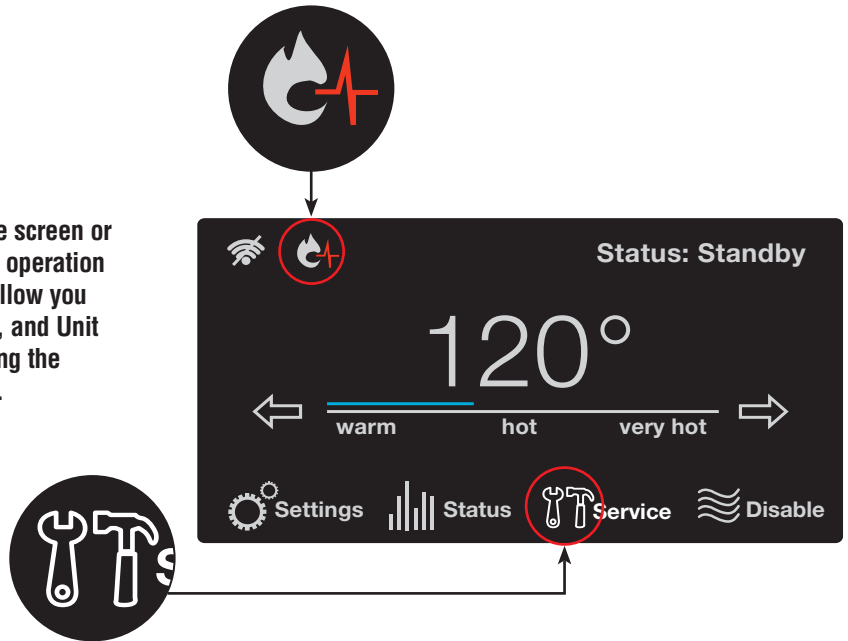

Problem	Possible Causes	What To Do
Display not on	No power to the unit	Check the breaker to the unit, the on/off switch, and the fuse on the ignition control board.
	Harness from control board disconnected	Make sure that the wire harness to J4 on the ignition control board is still connected.
Blower does not run	No power to blower motor	Verify power to the control board and that all harnesses to the blower are properly installed. Make sure that there is no damage the harnesses or connectors.
Unable to light the main burner	Air in gas line	Let the unit cycle at least 3 times to remove air from the gas line. If the unit does not try to light, contact a qualified service technician to purge the air from the gas line.
	Manual gas shut-off valve(s) not open	Check to make sure that all manual shut-off valves between the unit and the gas line are open.
	Blocked inlet or exhaust vent pipe	Contact a qualified service technician to evaluate vent pipes for a blockage.
	Pressure switch	Make sure the pressure switch hoses are not "kinked" or disconnected.
		Blocked inlet or outlet vent systems will cause pressure switch to shut off the unit. Contact a qualified service technician to evaluate the vent system.
Wire connection not fully secured	Contact a qualified service technician to confirm wire connections.	

BEFORE YOU CALL FOR SERVICE...



Troubleshooting Tips

Save time and money! Review the charts on the following pages first and you may not need to call for service.

Problem	Possible Cause	What To Do
Unable to light the main burner	Gas control problem	Contact a qualified service technician.
	Unit or electrical supply line not properly grounded	Verify that the electrical supply line and unit have proper ground connection.
Main burner does not stay lit	Burner flame not contacting sensor rod.	Call a qualified service technician to review flame rectification.
	Unit or electrical supply line not properly grounded	Verify the electrical supply line and unit have proper ground connection.
Not enough or no hot water	Water usage exceeded the capacity	Wait for the water heater to recover after an abnormal demand of the water heater.
	Low gas pressure	Check the gas supply pressure.
	Water heater set point is set too low	See the "User Interface" section of this manual to the set point temperature.
	Leaking or open hot water faucets	Make sure all faucets are closed.
	"ON/OFF" switch turned off	Turn the switch to the "ON" position.
	Colder supply water	Incoming water temperature might be lower than when the unit was initially installed. This will require a longer heat up cycle.
	Burner not staying on	Refer to the "Main Burner" section of this manual.
Water is too hot	The water heater set point is set too high	See the "User Interface" section of this manual to the set point temperature.

⚠ CAUTION:

Make certain power to the water heater is "OFF" before removing the protective cover FOR ANY REASON.

⚠ CAUTION:

Label all wires prior to disconnection when servicing controls. Wiring errors can cause improper and dangerous operation. VERIFY PROPER OPERATION AFTER SERVICING!

⚠ CAUTION:

For your safety, DO NOT attempt repair of gas piping, gas control burner, vent connectors or other safety devices. Refer repairs to qualified service personnel.

NOTE: A Training Manual is available through the Technical Services Department for a more detailed troubleshooting and repair guide.

BEFORE YOU CALL FOR SERVICE...

Alarm ('A') and Alert ('T') Codes	Description	Current Alarm Screen Display
A001	Ignition lockout due to a total of 9 consecutive failed ignitions. This will disable the heater.	A001 Ignition lockout. ->Clear error code by turning the unit off/on. If problem persists, contact technical support or service provider.
A002	Flame not stable lockout. Lost flame three times during one heat cycle. This will disable the heater.	A002 Flame is not stable. ->Clear error code by turning the unit off/on. If problem persists, contact technical support or service provider.
A003	The intake pressure switch was detected open when the blower was running. This will disable the heater.	A003 Intake Switch open. Check Wiring/Venting ->Check switch wiring and venting. If problem persists, contact technical support or service provider.
A004	The proof of air flow switch was detected open during heating operation. This will disable the heater.	A004 PoF Switch error H. Check Blower/Wiring. ->Check switch wiring and venting. If problem persists, contact technical support or service provider.
A005	The proof of air flow switch was detected open during pre-purge operation. This will disable the heater.	A005 PoF Switch error E. Check Blower/Wiring. ->Check switch wiring and venting. If problem persists, contact technical support or service provider.
A006	The proof of air flow switch was detected open during post purge operation.	A006 PoF Switch error P. Check Blower/Wiring. ->Check switch wiring and venting. If problem persists, contact technical support or service provider.
A007	Exhaust flue pressure switch was detected open during heating. This will disable the heater.	A007 Exhaust Switch open. Check Wiring/Venting ->Check switch wiring and venting. If problem persists, contact technical support or service provider.
A008	The proof of air flow pressure switch was detected closed before the blower started operation. This will disable the heater.	A008 PoF Switch/Blower mismatch. Call Tech Svc ->The Proof of Fan pressure switch is closed when the blower is off. Contact technical support or service provider.
A010	Ignition Control Test Failure during End of Line (EOL) test	: A010 Ignition Control Test Failure -> End of Line (EOL) test failure. Unit disabled.
A012	Flame Detected During Standby/Disabled Mode	A012 ->Clear error code by turning the unit off and on. If problem persists contact technical support or service provider

BEFORE YOU CALL FOR SERVICE...

Alarm ('A') and Alert ('T') Codes	Description	Current Alarm Screen Display
A016	Energy Cutout (ECO) switch is open. This will disable the heater.	A016 High Tank Temperature. Call Tech Service. ->Clear error code by pressing clear button. Refer to use and care manual for troubleshooting, or contact technical support.
A017	Flue (exhaust) gas temperature has exceeded 155°F. This will disable the heater.	A017 High Flue Temp. Recycle unit ON/OFF. ->Blower will continue to run until exhaust temperature has decreased. If problem persists contact technical support.
A018	Flue temperature sensor (thermistor) detected open. This will disable the heater.	A018 Flue Temp Sensor open. Check wiring. ->Check wiring to sensor. If condition persists refer to use and care manual or contact technical support.
A019	Flue temperature sensor (thermistor) detected short circuited. This will disable the heater.	A019 Flue Temp Sensor shorted. Call Tech Svc. ->Check wiring to sensor. If condition persists refer to use and care manual or contact technical support.
T020	Lower tank (inlet) temperature sensor (thermistor) detected open.	T020 Lower Tank Sensor open. Check wiring. ->Check wiring to sensor. If condition persists refer to use and care manual or contact technical support.
T021	Lower tank (inlet) temperature sensor (thermistor) detected short circuited.	T021 Lower Tank Sensor shorted. Call Tech Svc. ->Check wiring to sensor. If condition persists refer to use and care manual or contact technical support.
A022	Upper tank temperature sensor detected open. This will disable the heater.	A022 Upper Tank Sensor open. Check wiring. ->Check wiring to sensor. If condition persists refer to use and care manual or contact technical support.
A023	Upper tank temperature has exceeded 205°F. This will disable the heater.	A023 Upper Tank temp. too hot. Call Tech Svc. ->Clear error code by pressing clear button. Refer to use and care manual for troubleshooting, or contact technical support.
A024	Upper tank temperature sensor detected short circuited. This will disable the heater.	A024 Upper Tank sensor shorted. Call Tech Svc. ->Check wiring to sensor. If condition persists refer to use and care manual or contact technical support.

BEFORE YOU CALL FOR SERVICE...

Alarm ('A') and Alert ('T') Codes	Description	Current Alarm Screen Display
A025	Control does not detect blower RPM. This will disable the heater.	A025 No Blower RPM feedback. Call Tech Service ->Contact technical support or service provider.
A026	Blower RPM feedback (actual RPM) is ≥ 300 RPM from desired RPM for > 1 minute.	A026 Blower expected RPM vs actual RPM mismatch ->Contact technical support or service provider.
A027	Flame current detected prior to opening gas valve. This will disable the heater.	A027 Flame present before ignit. Call Tech Svc ->Clear error code by turning the unit off and on. If problem persists please contact technical support or service provider.
A028	Flame current detected 10 seconds after closing gas valve. This will disable the heater.	A028 Flame present w/o heating. Call Tech Svc. ->Clear error code by turning the unit off and on. If problem persists please contact technical support or service provider.
T029	Unit did not light.	T029 Failed ignition. Retrying.
A030	Unit lost flame.	A030 Flame lost during heating. Retrying.
T032	Lower (inlet) thermistor analog to digital converter fault.	T032 Lower Tank temp A/D error. Call Tech Svc. ->If problem persists, please contact technical support or service provider.
A033	Exhaust flue thermistor analog to digital converter fault. This will disable the heater.	A033 Flue sensor A/D error. Call Tech Service. ->If problem persists, please contact technical support or service provider.
A034	Upper tank thermistor analog to digital converter fault. This will disable the heater.	A034 Upper Tank temp A/D error. Call Tech Svc. ->If problem persists, please contact technical support or service provider.
T035	Gas relay #1 contacts did not close. The unit will continue to try and close the relay to initiate combustion.	A035 Gas Relay 1 stuck open. Call Tech Service ->If problem persists, please contact technical support or service provider.
A036	Gas relay #1 stuck closed. This could inadvertently allow the gas valve to open. This will disable the heater.	A036 Gas Relay 1 stuck closed. Call Tech Svc. ->If problem persists, please contact technical support or service provider.
A037	Gas relay #2 contacts failed to properly close. This can cause gas valve cycling and gas buildup in the burn chamber. This will disable the heater.	A037 Gas Relay 2 stuck open. Call Tech Service ->If problem persists, please contact technical support or service provider.

BEFORE YOU CALL FOR SERVICE...

Alarm ('A') and Alert ('T') Codes	Description	Current Alarm Screen Display
A038	Gas relay #2 stuck closed. This could inadvertently allow the gas valve to open. This will disable the heater.	A038 Gas Relay 2 stuck closed. Call Tech Svc. ->If problem persists, please contact technical support or service provider.
A039	This is a control board hardware fault and requires control board replacement if persistent. This will disable the heater.	A039 Flame sense cct fault. Call Tech Service ->If problem persists, please contact technical support or service provider.
A040	This is a control board hardware fault and requires control board replacement if persistent. This will disable the heater.	A040 Controller RAM fault. Call Tech Service. ->If problem persists, please contact technical support or service provider.
A041	This is a control board hardware fault and requires control board replacement if persistent. This will disable the heater.	A041 Controller ROM fault. Call Tech Service. ->If problem persists, please contact technical support or service provider.
A042	This is a control board hardware fault and requires control board replacement if persistent. This will disable the heater.	A042 Controller EEPROM fault. Call Tech Svc. ->If problem persists, please contact technical support or service provider.
A043	This is a control board hardware fault and requires control board replacement if persistent. This will disable the heater.	A043 IC Program execution fault. Call Tech Svc ->If problem persists, please contact technical support or service provider.
A044	Input power frequency not 60 Hz. (outside allowable deviation). This will disable the heater.	A044 Processor Clock/Line Frequency Disagree ->If problem persists, please contact technical support or service provider.
A047	Resistance for the Flammable Leak Sensor has fallen outside the expected operational range.	A047 Flammable Leak Sensor Failure -> If problem persists, please contact technical support or service provider.
A048	Resistance for the Flammable Leak Sensor has exceeded a specified threshold indicating a flammable vapor has been detected but the sensor is operating within designed range.	A048 Flammable Leak Detected -> If problem persists, please contact technical support or service provider.
A101	This is a display board hardware fault and requires control board replacement if persistent. This will disable the heater.	A101 Configuration Data Restore Failure ->Initialization of the control system failed at startup. Please contact technical support or service provider.
A102	Set the internal clock time.	A102 Time Clock needs to be programmed ->Go to Settings, select time/date menu and set the time and date.
A103	This is a display board hardware fault and requires control board replacement if persistent. This will disable the heater.	A103 Time Clock not advancing time properly ->contact your qualified service provider.

BEFORE YOU CALL FOR SERVICE...

Alarm ('A') and Alert ('T') Codes	Description	Current Alarm Screen Display
A104	Presence of water detected by the leak sensor in the bottom pan. If water is seen locate source and take appropriate action to correct the issue. This may disable the heater based on configuration settings.	A104 Water Leak Detected ->The presence of water has been detected by the control. Please contact a qualified service provider.
T105	Check to see if leak sensor is installed in the bottom pan. Check wiring on connector P11 of the ignition control board.	T105 Water Leak Sensor Not Installed ->Check water leak sensor connection. Refer to use and care manual for troubleshooting, or contact technical support.
A108	Communication lost between the display board and the ignition control board. The ignition control board will continue to operate the heater using the last known configuration settings. Check wiring between the display and P5 of the ignition control board.	A108 Ignition Board Communication Failure ->Communications lost with ignition control board. If problem persists, contact technical support or service provider.
A110	Monthly test of automatic shutoff valve (premium models only) was not completed properly. The valve did not close in the allotted time.	A110 Shutoff Valve Test Close Error ->Auto Shutoff valve failed to close during test cycle. Please contact technical support or service provider.
A111	Monthly test of automatic shutoff valve (premium models only) was not completed properly. The valve did not open in the allotted time. This will disable the heater.	A111 Shutoff Valve Test Open Error ->Water heater has been disabled. Manually open valve. Contact technical support or service provider.
A112	Automatic shutoff valve (premium models only) is closed. This will disable the heater.	A112 Shutoff Valve Not Open: Heating Disabled ->Manually open valve if no water detected or if unit is not being serviced. Contact technical support or service provider.
T113	Peak flame rod current has deviated from the startup average. This is indicative of degradation of the flame rod (dirty, sooty). It needs to be cleaned and inspected.	T113 Flame Rod Degraded and Needs Servicing ->Clean or replace per use and care manual. Please contact technical support for assistance.
T114	Peak flame rod current has deviated from the startup average by a significant amount. Clean and inspect flame rod. Replace if necessary.	T114 Flame Rod Degraded and Needs Servicing ->Clean or replace per use and care manual. Contact technical support for assistance.
T115	Monitored characteristics of the combustion system indicate degraded performance. Combustion system needs to be inspected and serviced.	T115 Combustion Health Degraded: Needs Service ->Combustion system performance is degraded. Contact technical support or service provider for assistance.
T116	Monitored characteristics of the combustion system indicate severely degraded performance. Combustion system needs to be inspected and serviced.	T116 Combustion Health Degraded. Needs Service ->Clear error code by pressing clear button. Refer to use and care manual for troubleshooting, or contact technical support.

BEFORE YOU CALL FOR SERVICE...

Alarm ('A') and Alert ('T') Codes	Description	Current Alarm Screen Display
T117	Periodic maintenance, inspection, and upkeep on the unit.	T117 Time to Drain and Inspect Tank ->Refer to the use and care manual for instructions, or contact technical support or service provider.
T118	Periodic maintenance, inspection, and upkeep on the unit.	T118 Time to Check Venting for Debris ->Refer to the use and care manual for information, or contact technical support or service provider.
T119	Periodic maintenance, inspection, and upkeep on the unit.	T119 Time to Clean Out the Condensate Drain Trap ->Refer to the use and care manual for instructions and locations. Call technical support or service provider if necessary.
T120	Periodic maintenance, inspection, and upkeep on the unit.	T120 Time to Replace the Neutralizer ->Clear error code by pressing clear button. Refer to use and care manual for troubleshooting, or contact technical support.
A143	The switch information on the Shutoff Valve is indicating incorrect information such as both switches are OPEN or both switches are CLOSED.	A143 Shutoff Valve Inputs in Error ->Manually open valve if no water detected or if unit is not being serviced. Contact technical support or service provider.
A200	Software versions between the Display Control and Ignition Control are incompatible.	A200 Incompatible Ignition Control/Display Error ->The ignition control and display are incompatible with each other. Contact technical support.
T504	WiFi chip communication timing error. This doesn't mean the chip has failed.	T504 Wifi Chip Communication Error ->Refer to the use and care manual for information, or contact technical support or service provider.

REPLACEMENT PARTS

Instructions For Placing a Parts Order

All parts orders should include:

The model and serial number of the water heater from the rating plate.

Specify type of gas (natural or LP) as marked on the rating plate.

Part description (as noted below) and number of parts desired.

⚠ CAUTION

For your safety **DO NOT** attempt repair of gas piping, gas control burner, vent connectors or other safety devices. Refer repairs to qualified service personnel.

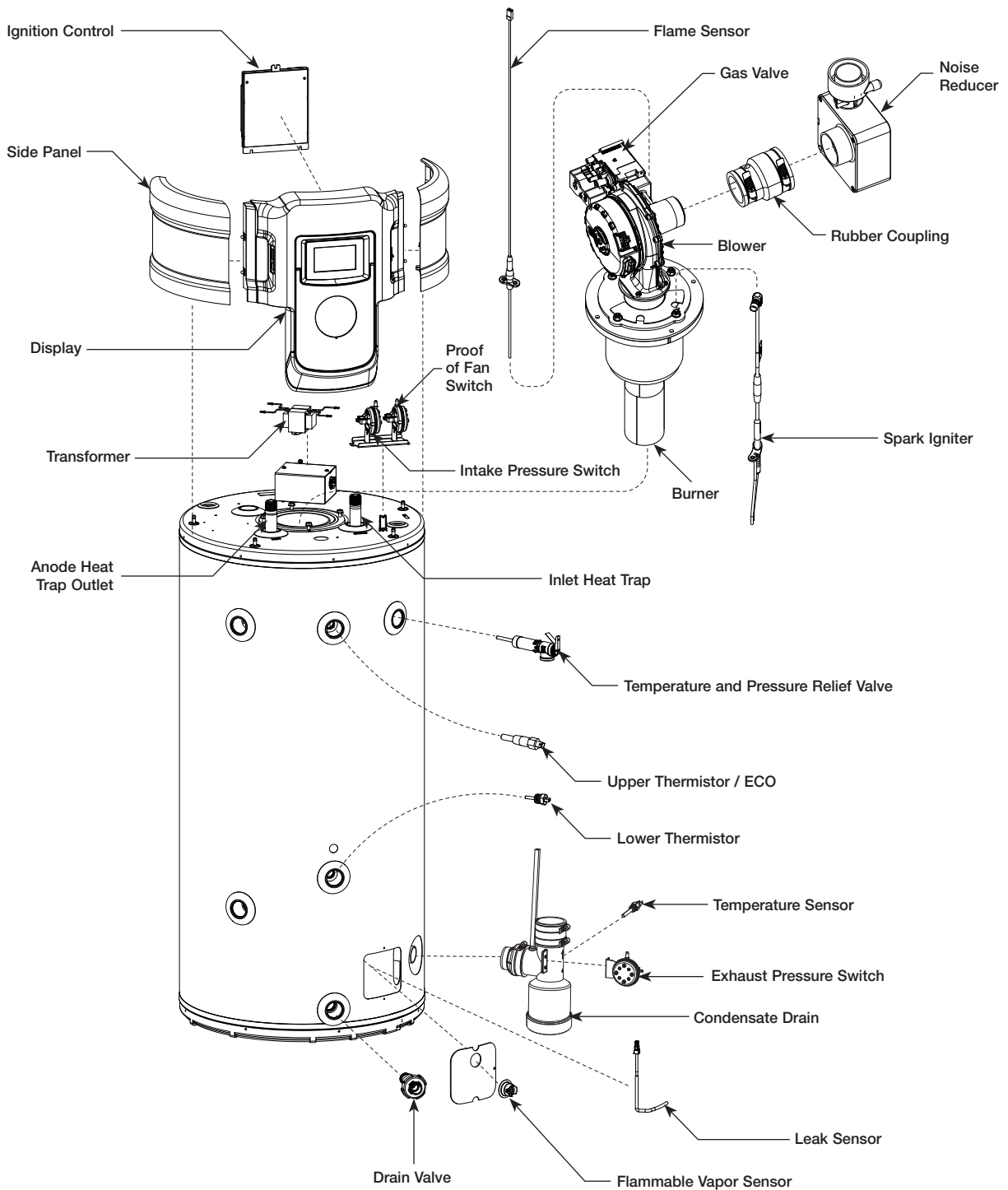

WIRING AND SCHEMATIC DIAGRAMS

⚠️ WARNING:

NOTICE: DO NOT use in conjunction with a GFCI. To avoid the risk of fire, explosion or asphyxiation from carbon monoxide, NEVER operate this water heater unless it is properly vented and has an adequate air supply for proper operation. It is important that the vent pipe engages fully into any pipe fitting and be kept in that position until the adhesive has fully cured. DO NOT drill or punch holes in the plastic pipe or fittings.

Standard

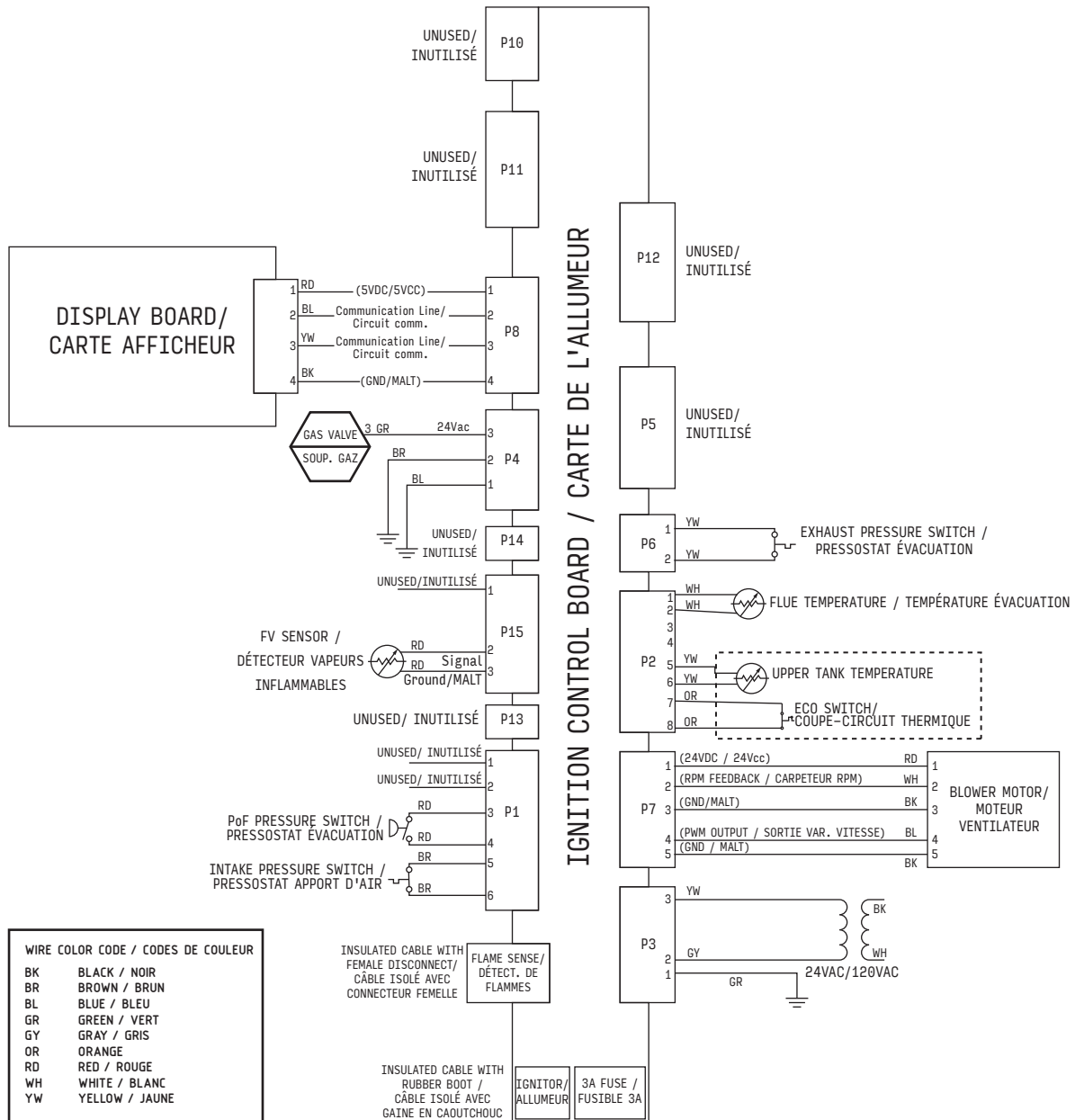

⚠️ CAUTION

Label all wires prior to disconnection when servicing controls. Wiring errors can cause improper and dangerous operation. VERIFY PROPER OPERATION AFTER SERVICING!

WIRING AND SCHEMATIC DIAGRAMS

Premium

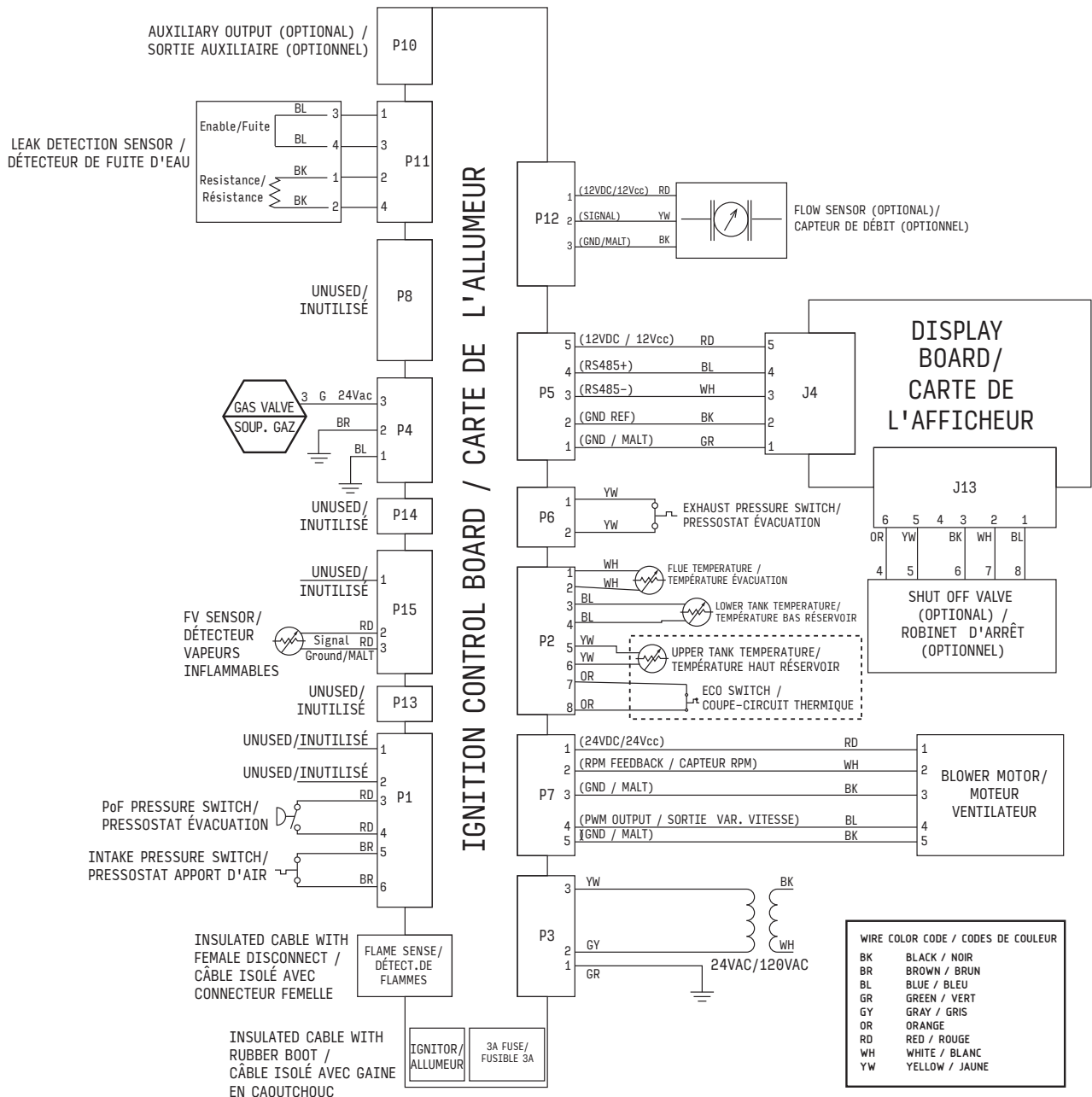

HOW TO OBTAIN SERVICE ASSISTANCE

1. Should you have any questions about your new water heater, or if it requires adjustment, repair, or routine maintenance, it is suggested that you first contact your installer, plumbing contractor or previously agreed upon service agency. In the event the firm has moved, or is unavailable, refer to the telephone directory, commercial listings or local utility for qualified service assistance.
2. Should your problem not be solved to your complete satisfaction, you should then contact the Manufacturer's National Service Department at the following address:

Rheem Canada, Ltd.
125 Edgeware Road, Unit 1
Brampton, ON L6Y 0P5
Phone: 1-800-268-6966.

When contacting the manufacturer, the following information will be requested:

- a. Model and serial number of the water heater as shown on the rating plate attached to the jacket of the heater.
- b. Address where the water heater is located and physical location.
- c. Name and address of installer and any service agency who performed service on the water heater.
- d. Date of original installation and dates any service work was performed.
- e. Details of the problems as you can best describe them.
- f. List of people, with dates, who have been contacted regarding your problem.